

BAA K660

Version 1.00

Butterfly valve - model 2007

DN 15 – 100, DN 1/2” – 4”

DN 15-ISO – DN 100-ISO

Manual and pneumatic operation

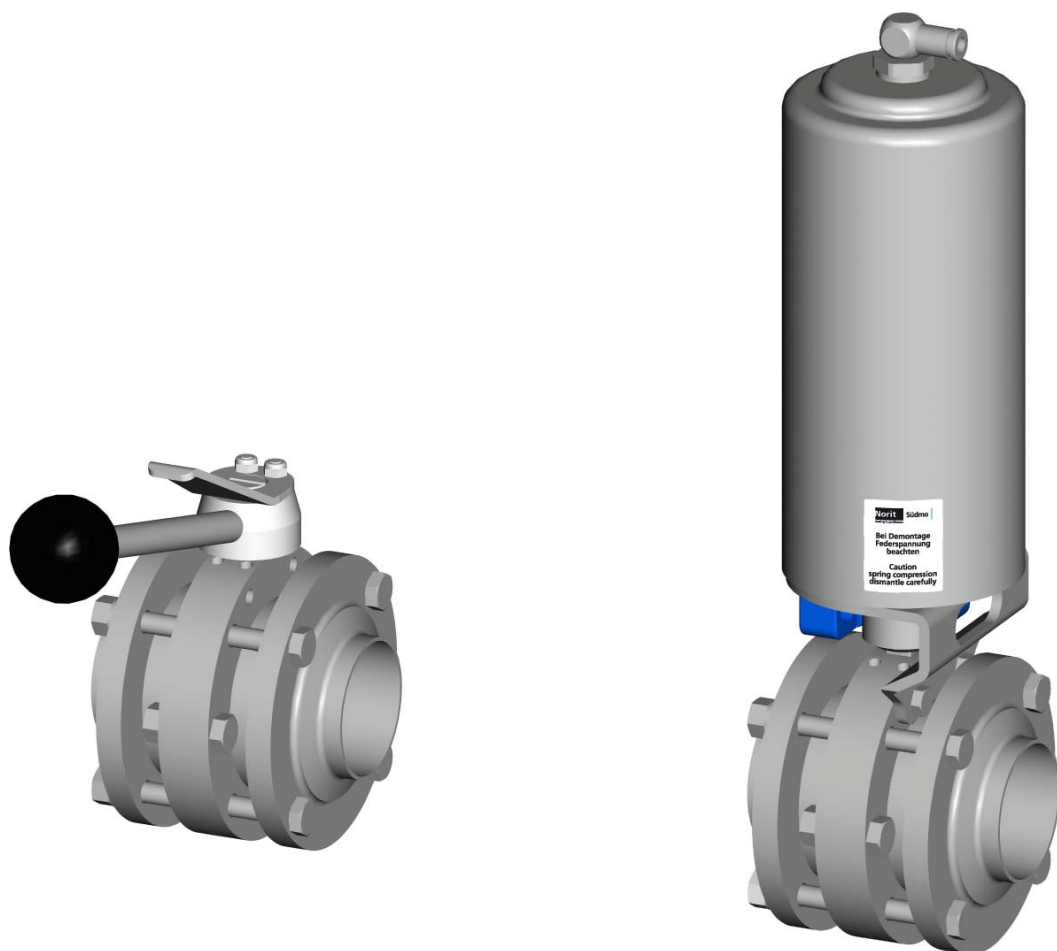

Revision	Date	Name	Revision	Date	Name	Revision	Date	Name	Revision	Date	Name	

created on/by 22.09.2010 Graf H.
 reviewed on/by 22.09.2010 Deger W.



en

1. Contents

1.	Contents	2
2.	Safety instructions	5
2.1.	General information	5
2.2.	Maintenance and service work	5
2.3.	Modifications to the butterfly valve	6
2.4.	Butterfly valve with feedback	6
2.4.1.	Manual operation	6
2.4.2.	Pneumatic operation	7
2.5.	Storage	7
2.6.	Operation	7
2.7.	Spare parts	7
2.8.	Risk assessment	7
3.	Field of application	8
3.1.	Field of application of the butterfly valves	8
3.2.	Pressure parameters	8
3.3.	Temperature	8
3.4.	Media to be transported	8
3.5.	Media to be transported in areas subject to explosion hazards	8
4.	Technical data	9
4.1.	Dimensions	9
4.1.1.	Metric design - Butterfly valve for pipe connection according to DIN 11850 and threaded connections according to DIN 11851	9
4.1.2.	Design based on inch-system - Butterfly valve for pipe connections according to DIN 11866	10
4.1.3.	ISO design - Butterfly valve for pipe connection according to DIN EN ISO 1127 and threaded connections according to DIN 11864-1 form A	11
4.2.	Valve use	12
4.3.	Material data	12
4.3.1.	Sealing materials	12
4.3.2.	Valve materials	13
4.4.	CIP cleaning	13
4.5.	Surfaces	13
4.6.	Feedback systems for butterfly valves	13
4.6.1.	Manual butterfly valve - Simple feedback	13
4.6.2.	Manual butterfly valve - Double feedback	14
4.6.3.	Pneumatic butterfly valve - Simple feedback	14
4.6.4.	Pneumatic butterfly valve - Double feedback	14
4.6.5.	Pneumatic butterfly valve - Process control unit IntelliTop® 1.0	15
4.6.6.	Pneumatic butterfly valve - Process control unit IntelliTop® 2.0	15
4.7.	Electrical and pneumatic connections	15
4.7.1.	Electrical connections	15
4.7.2.	Pneumatic connections	15
4.8.	Control air	16
4.8.1.	Control air pressure	16
4.8.2.	Control air quality	16



5. Valve function	17
5.1. Manual butterfly valve	17
5.2. Pneumatic butterfly valve	17
5.2.1. Operating mode air to open - spring to close	17
5.2.2. Mode of operation spring to open - air to close	17
5.2.3. Mode of operation air to open - air to close	17
5.3. Pneumatic multiturn actuator air to open - spring to close with a three-position drive	18
6. Valve connection piping	19
6.1. Installation position	19
6.2. Valve connections	19
6.3. Mounting instructions for butterfly valves	19
7. Welding and mounting instructions	19
7.1. General notes	19
7.2. As-delivered condition of the butterfly valve	19
7.3. Installation instructions	19
7.3.1. Installation space	19
7.3.2. Installation	20
7.4. Welding directives	20
7.5. Weld seam preparation	20
7.6. Welding	20
7.7. Welding filler	20
7.8. Weld seam finishing	20
7.8.1. Interior	20
7.8.2. Exterior	20
7.9. Cleaning of the valve	20
7.10. Valve assembly	21
8. Disassembly – Assembly	21
8.1. Preparatory measures for dismounting - mounting	21
8.2. Safety instructions regarding butterfly valves with feedback unit	22
8.2.1. Manual operation	22
8.2.2. Pneumatic operation	22
8.3. Spare parts	22
8.4. Disassembly and assembly of the manual butterfly valve	23
8.5. Disassembly and assembly of the manual butterfly valve - version with intermediate clamping	25
8.6. Disassembly and assembly of the pneumatic butterfly valve	27
8.7. Disassembly and assembly of the pneumatic butterfly valve - version with intermediate clamping	29
8.8. Mounting the seal on the valve disk	31
8.9. Disassembly and assembly of the pneumatic multiturn actuator	32
8.9.1. Mode of operation air to open– spring to close, spring to open– air to close	32
8.9.2. Mode of operation air to open - air to close	34
8.10. Assembling and disassembling the pneumatic multiturn actuator with a three-position drive	36
8.10.1. Subsequent installation of the three-position drive	36
8.10.2. Replacing the seal of the three-position drive	37
8.11. Installation of the process control unit IntelliTop® on the pneumatic multiturn actuator	38
8.11.1. Process control unit IntelliTop® 1.0	38
8.11.2. Process control unit IntelliTop® 2.0	39

9. Putting the butterfly valve into operation	40
9.1. Functional check of the butterfly valve	40
9.1.1. Manual operation	40
9.1.2. Pneumatic operation	40
9.2. Tightness test of the butterfly valve	40
10. Maintenance of butterfly valve	40
10.1. Preparatory maintenance measures	40
10.2. Inspection of the butterfly valve	41
10.3. Maintenance of the butterfly valve	41
11. Malfunctions - Troubleshooting	42
12. Disposal	42
13. Spare parts list	43
13.1. Butterfly valve	44
13.2. Pneumatic multiturn actuator DN 15 – 100, DN 1/2” – 4”, DN 15-ISO – DN 100-ISO	49
13.3. Pneumatic three-position drive	51
14. EC Declaration of Incorporation	52
15. Declaration of Conformity	53
16. Manufacturer's declaration for use at locations subject to explosion hazards	54
17. Service address	56

2. Safety instructions



Danger

*This symbol denotes an **imminent danger to life and health of persons!**
Non-observance of these instructions leads to health risks or life-threatening injuries.*



Caution

*This symbol denotes a **potentially dangerous situation!**
Non-observance of these instructions can lead to light injuries or damage to material property.*



This symbol gives important information on the proper handling of the butterfly valve which must be strictly observed.

Non-observance of these instructions can result in malfunction of the valve or in its environment.

2.1. General information

- ⇒ The butterfly valves by Südmo Components GmbH have been manufactured in accordance with the state-of-the-art standards and recognized safety rules. However, these butterfly valves may constitute a hazard if used improperly by operating personal or for a purpose other than the designated one. This may result in a risk to life and limb of the user or of third parties, impair the function of the butterfly valve or cause damage to other material property.
- ⇒ Anyone who has been designated by the purchaser to assemble, start up, operate and maintain these butterfly valves must have read and understood the complete operating instructions (especially all specified safety instructions).
- ⇒ In addition to these operating instructions the following applies as a matter of course:
 - relevant accident prevention regulations
 - generally accepted safety rules
 - national regulations in the country of use
 - company-internal instructions concerning work and safety.

2.2. Maintenance and service work

- ⇒ Any maintenance and service work on the butterfly valves must be carried out by specially trained, qualified personnel only.
 - Training or instruction in accordance with the current safety standards.
 - For systems with explosion protection:
 - training or instruction resp. authorization to carry out work on systems subject to explosion hazards (observe ATEX regulations).

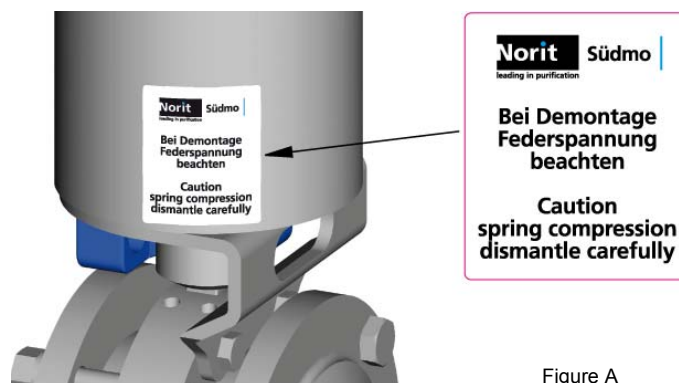
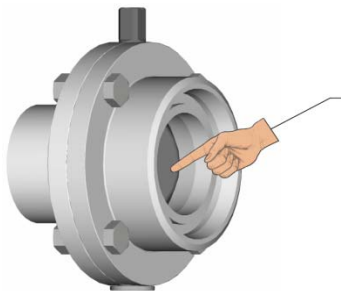

Figure A

- ⇒ Get information on possible risks that could be caused by residues of the operating material and take appropriate measures if necessary (safety gloves, safety goggles, etc.), before carrying out maintenance and service work on the butterfly valve.
- ⇒ Prior to carrying out any maintenance and service work, make sure that:
 - this work is only carried out in depressurized state and with the media supply shut off.
 - the butterfly valve and all piping elements leading to the valve have been drained and cleaned or flushed.
 - the fittings have been cooled down.
 - the system is not started by a third person.
 - the pressure build-up which may form in sealed pipelines is counteracted.
 - dismounting - mounting of the butterfly valve are carried out according to the mounting instructions (see chapter 8 "Dismounting - Mounting").
 - the power supply has been disconnected.
 - the butterfly valve is removed from the piping section, if possible.



Do not reach into the valve opening

⇒ **Danger of accident.**

Risk of limbs being crushed or cut off.

- ⇒ Avoid any working method impairing safety and function of the butterfly valve.

2.3. Modifications to the butterfly valve



⇒ **Operate the butterfly valve according to the designated use and safety instructions.**

⇒ **Operate the butterfly valve in perfect technical condition only.**

⇒ **Modifications to the butterfly valve are not allowed.**

2.4. Butterfly valve with feedback

2.4.1. Manual operation



Do not reach into the feedback unit

⇒ **Danger of accident.**

Risk of limbs being crushed or cut off.

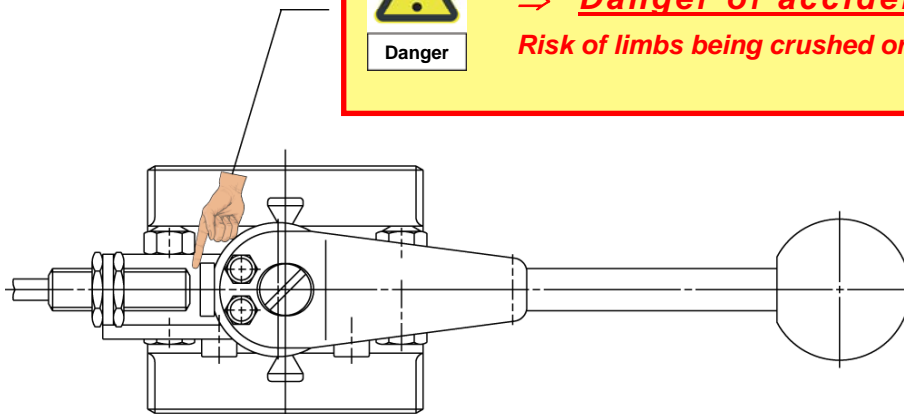

2.4.2. Pneumatic operation



Do not reach into the feedback unit
⇒ **Danger of accident.**
Risk of limbs being crushed or cut off.

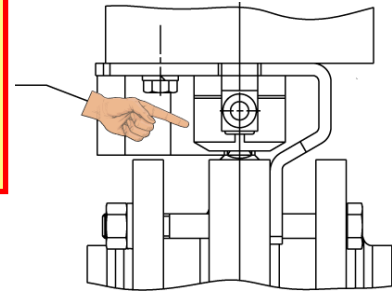

2.5. Storage

- ⇒ Store the valve in a dry place protected against external influences.
- ⇒ Prior to handling (disassembly of the body / activation of the actuators) temporarily store the valves in a dry place for at least 24 hours at a temperature $\geq 5^\circ \text{C}$.

2.6. Operation



- ⇒ **Never touch the valve or the pipelines if hot media are processed or if the sterilizing process is running.**
- ⇒ **Always adhere exactly to the operating parameters (see chapter 4 "Technical Data").**

2.7. Spare parts



- ⇒ **Use original spare parts only.**
- ⇒ **For original spare parts, refer to the enclosed spare parts list (see chapter 13 "Spare parts list").**
- ⇒ **Perfect functioning of the butterfly valve is only guaranteed when using original spare parts.**

2.8. Risk assessment

- ⇒ All safety instructions in these operating instructions result from the risk assessment for the butterfly valve.

3. Field of application

3.1. Field of application of the butterfly valves

The Norit Südmo butterfly valves are used, among others, in

- ⇒ breweries
- ⇒ the beverage industry
- ⇒ the foodstuffs industry
- ⇒ the pharmaceutical industry
- ⇒ the chemical industry
- ⇒ the cosmetic industry

3.2. Pressure parameters

Max. allowed operating pressure 10 bar

Shut-off tightness:

Sealing material	Shut-off tightness
EPDM	max. 10 bars
VMQ	max. 10 bars
FPM	max. 6 bars
HNBR	max. 10 bars

3.3. Temperature

Max. allowed operating temperature

Sealing material	Continuous operating temperature	Short-term operating temperature
EPDM	-5° C to +130° C	-5° C to +150° C
VMQ	0° C to +130° C	-----
FPM	-5° C to +130° C	-----
HNBR	0° C to +130° C	0° C to +150° C



Please observe the restrictions imposed by the sealing material used in combination with the medium to be transported. For more information on this, see chapter 4.3. "Technical Data - Sealing materials".

3.4. Media to be transported

Allowed state of aggregation

Liquids / Gases / Solids

Inadmissible media

radioactive, poisonous, very poisonous and environmentally hazardous media

3.5. Media to be transported in areas subject to explosion hazards

Allowed state of aggregation

Liquids / Gases / Solids

Inadmissible media

radioactive, poisonous, very poisonous and environmentally hazardous media



In addition, the restrictions according to the Manufacturer's Declaration for use in areas subject to explosion hazards must be observed. For more information on this, see also chapter 16. "Manufacturer's declaration for use in areas subject to explosion hazards".

4. Technical data

4.1. Dimensions

4.1.1. Metric design - Butterfly valve for pipe connection according to DIN 11850 and threaded connections according to DIN 11851

All dimensions of the connection types are applicable for the manually and for the pneumatically operated butterfly valve.

Dimensions for other connection types on demand.

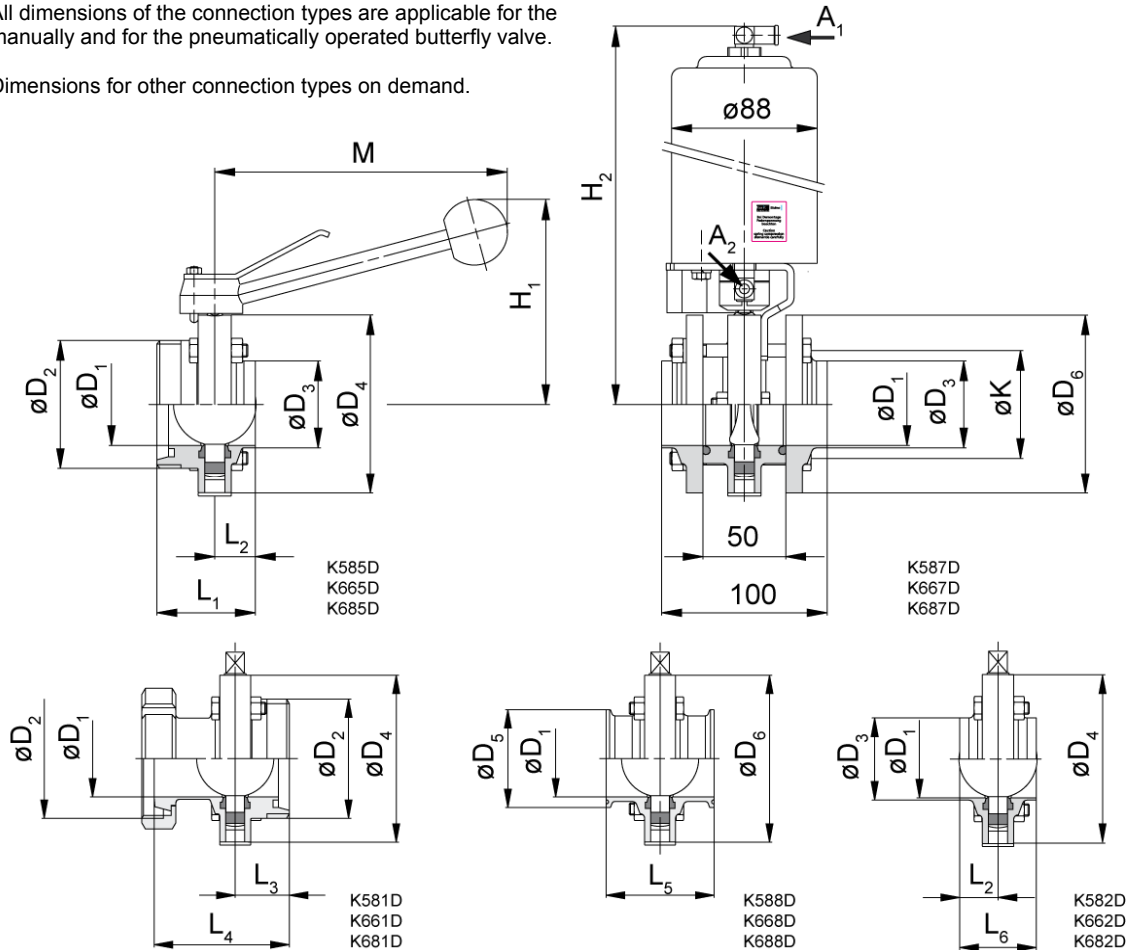

DN	øD ₁	øD ₂	øD ₃	øD ₄	øD ₅	øD ₆	H ₁	H ₂	øK	L ₁	L ₂	L ₃	L ₄	L ₅	L ₆	M
15	16	Rd 34 x1/8"	19	62	-----	62.5	92	284	50	55	25	30	71.5	-----	50	150
20	20	Rd 44 x1/6"	23	70	-----	62.5	96	291	50	60	25	35	77.5	-----	50	150
25	26	Rd 52 x1/6"	29	84	50.5	84	103	294	67	60	25	35	81.5	70	50	150
32	32	Rd 58 x1/6"	35	90	-----	90	106	297	73	60	25	35	81.5	-----	50	150
40	38	Rd 65 x1/6"	41	96	50.5	96	109	301	80	60	25	35	85.5	70	50	150
50	50	Rd 78 x1/6"	53	109	64	109	126	309	93	60	25	35	87.5	70	50	177
65	66	Rd 95 x1/6"	70	126	91	126	135	316	110	62	25	37	93.5	74	50	177
80	81	Rd 110 x1/4"	85	141	106	141	142	325	125	85	42.5	42.5	121.5	85	85	177
100	100	Rd 130 x1/4"	104	161	119	161	152	337	145	85	42.5	42.5	128.5	85	85	177

Dimensions in mm

4.1.2. Design based on inch-system - Butterfly valve for pipe connections according to DIN 11866

All dimensions of the connection types are applicable for the manually and for the pneumatically operated butterfly valve.

Dimensions for other connection types on demand.

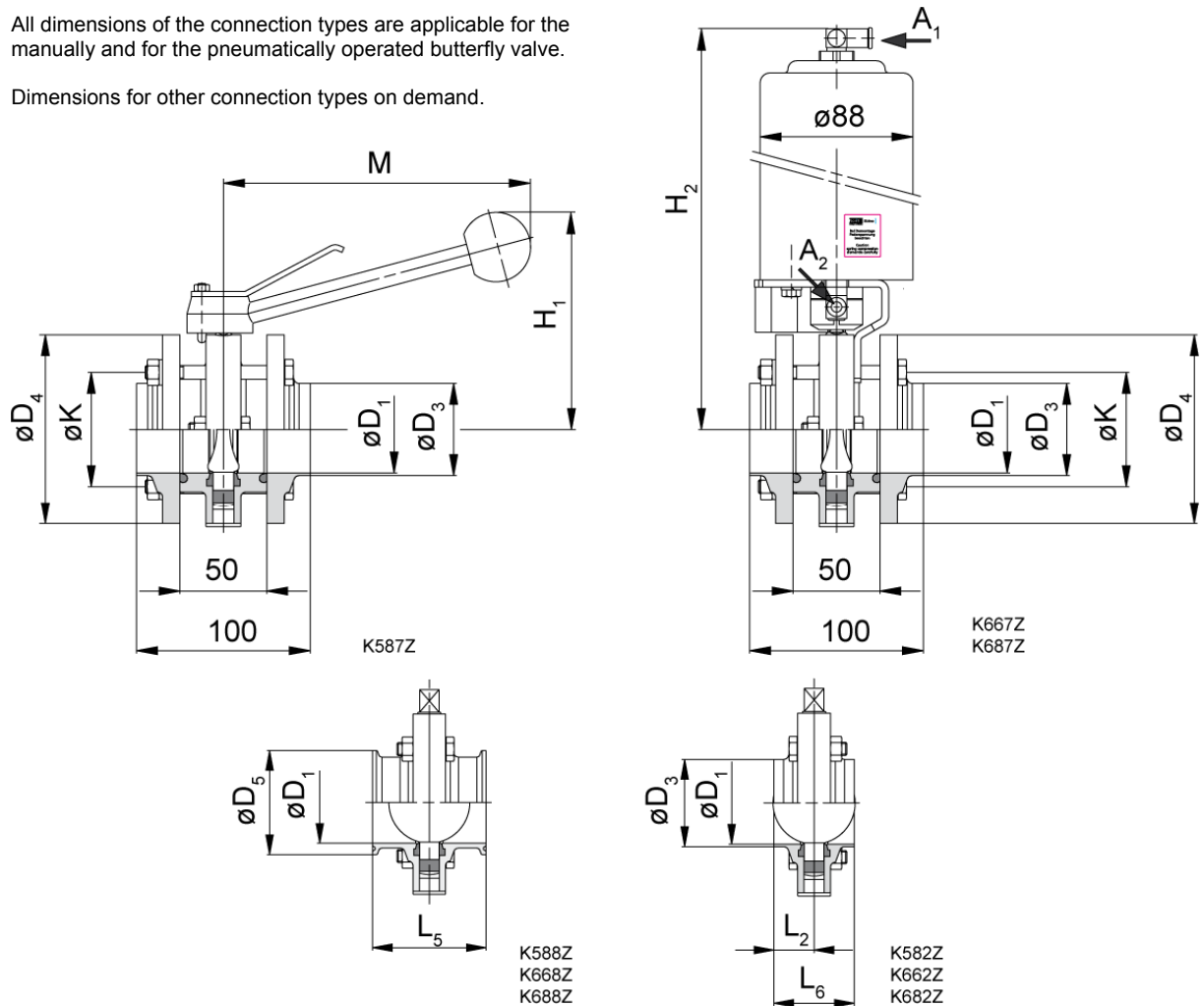

DN	øD ₁	øD ₃	øD ₄	øD ₅	øD ₆	H ₁	H ₂	øK	L ₂	L ₅	L ₆	M
1/2"	9.4	12.7	62	----	62.5	92	284	50	25	----	50	150
3/4"	15.8	19.05	70	----	62.5	96	291	50	25	----	50	150
1"	22.1	25.4	84	50.5	84	103	294	67	25	70	50	150
1 1/2"	34.8	38.1	96	50.5	96	109	301	80	25	70	50	150
2"	47.5	50.8	109	64	109	126	309	93	25	70	50	177
2 1/2"	60.2	63.5	126	77.5	126	135	316	110	25	74	50	177
3"	72.9	76.2	141	91	141	142	325	125	42.5	85	85	177
4"	97.4	101.6	161	119	161	152	337	145	42.5	85	85	177

Dimensions in mm

4.1.3. ISO design - Butterfly valve for pipe connection according to DIN EN ISO 1127 and threaded connections according to DIN 11864-1 form A

All dimensions of the connection types are applicable for the manually and for the pneumatically operated butterfly valve.

Dimensions for other connection types on demand.

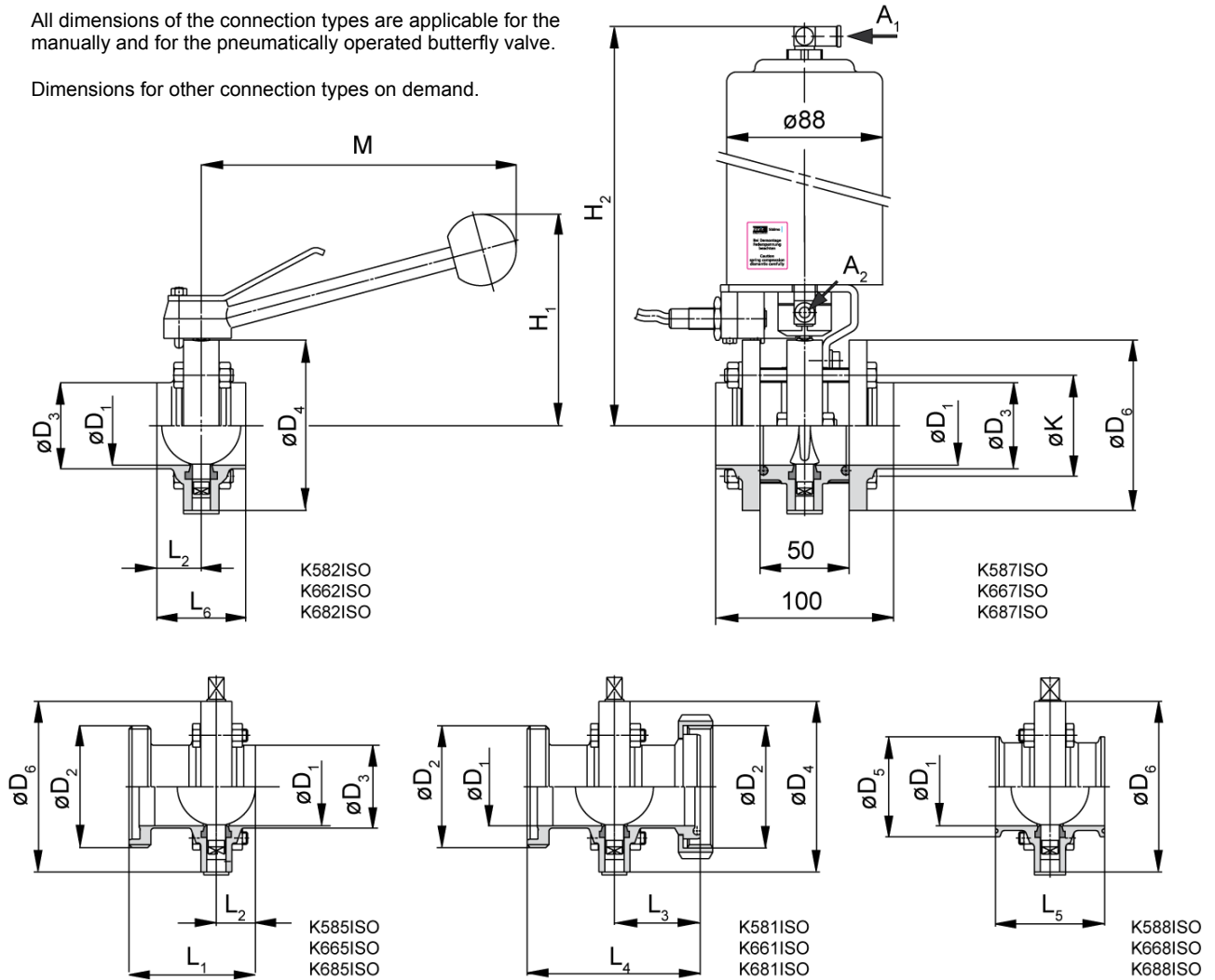

ISO	øD ₁	øD ₂	øD ₃	øD ₄	øD ₅	øD ₆	H ₁	H ₂	øK	L ₁	L ₂	L ₃	L ₄	L ₅	L ₆	M
15																
20																
25	29.7	Rd 58 x1/6"	33.7	84	50.5	84	103	294	67	80	25	50	105	70	50	150
32	38.4	Rd 65 x1/6"	42.4	96	64	96	109	301	80	81	25	51	107	70	50	150
40	44.3	Rd 78 x1/6"	48.3	96	64	96	109	301	80	81	25	55	111	70	50	150
50	56.3	Rd 95 x1/6"	60.3	109	77.5	109	126	309	93	86	25	59	120	70	50	177
65	71.5	Rd 110 x1/4"	76.1	141	91	141	142	316	125	127	42.5	80	164	85	85	177
80	84.3	Rd 130 x1/4"	88.9	141	106	141	142	325	125	135	42.5	88	180	85	85	177
100	109.1	-----	114.3	161	130	161	152	327	145	-----	42.5	-----	-----	85	85	177

Dimensions in mm

4.2. Valve use

Application: Shut-off valve
 For use in: low-germ processes
 Shut-off tightness:

Sealing material	Shut-off tightness
EPDM	max. 10 bars
VMQ	max. 10 bars
FPM	max. 6 bars
HNBR	max. 10 bars

Vacuum: Leakage rate (residual pressure in the test item 0.5 mbar) = 1.6×10^{-6}

4.3. Material data

4.3.1. Sealing materials

- ⇒ EPDM
 Temperature for continuous application in air: -5° C to +130° C
 Resistant to
 Hot water up to 100° C
 Steam up to 130° C continuous load, short-term up to 150° C
 Wort up to 100° C
 Sodium hydroxide up to 100° C and a concentration of up to 5 %
 Nitric acid up to 60° C and a concentration of up to 3 %
 Peracetic acid up to 80° C and a concentration of up to 0.7 %
 Raspberry flavor at room temperature
 Cherry flavor at room temperature
- ⇒ VMQ
 Temperature for continuous application in air: 0° C to +130° C
 Resistant to
 Hot water: up to 100° C
 Sodium hydroxide: up to 60° C and a concentration of up to 2.5 %
 Nitric acid: up to 60° C and a concentration of up to 1.2 %
 Peracetic acid: up to 80° C and a concentration of up to 0.7 %
- ⇒ HNBR
 Temperature for continuous application in air: -5° C to +130° C
 Resistant to
 Hot water up to 100° C
 Steam up to 130° C continuous load, short-term up to 150° C
 Sodium hydroxide up to 100° C and a concentration of up to 5 %
 Nitric acid up to 60° C and a concentration of up to 1.5 %
- ⇒ FPM
 Temperature for continuous application in air: 0° C to +130° C
 Resistant to
 Hot water up to 80° C
 Sodium hydroxide up to 60° C and a concentration of up to 2.5 %
 Peracetic acid at room temperature and a concentration of up to 0.7 %
 Orange flavor at room temperature
 Mandarin flavor at room temperature

	<p>The service life of the seals depends on:</p> <ul style="list-style-type: none"> ⇒ Operating time per day ⇒ Number of switching intervals ⇒ Type of product, temperature, etc. ⇒ Type of cleaning (CIP / SIP)
---	---

4.3.2. Valve materials

In contact with product	Standard	1.4307 (AISI 304 L) 1.4404 (AISI 316 L)
	Option	1.4435 (AISI 316 L)
Not in contact with product	1.4301 (AISI 304) / 1.4307 (AISI 304 L)	

4.4. CIP cleaning

i

- ⇒ Valve inner chambers must be cleaned regularly.
- ⇒ When selecting the detergent, please observe the following:
 - Do not use abrasive detergents.
 - Use only detergents that are suitable for seals and stainless steel.
- ⇒ Do not exceed the concentrations and temperatures recommended by the detergent manufacturer.
- ⇒ Observe the safety data sheets issued by the detergent manufacturers!
- ⇒ Non-observance of these instructions will exempt the manufacturer from any warranty and liability.

Cleaning example for EPDM process valves in the food industry:

Cleaning step	Description
Pre-rinsing	Process water at ambient temperature
Main cleaning process I (caustic step)	Caustic in aqueous solution 3% at 80°C
Intermediate rinsing	Process water at ambient temperature
Main cleaning process II (acid step)	Acid in aqueous solution 2% at 60°C
Final rinsing	Water (drinking water quality) at ambient temperature

4.5. Surfaces

Surfaces in contact with the product	Standard Surface versions	$R_a \leq 0.8 \mu\text{m}$ - e-polished - higher-quality surfaces
Surfaces not in contact with the product	bright metal finish, $R_a \leq 1.6 \mu\text{m}$	

4.6. Feedback systems for butterfly valves

4.6.1. Manual butterfly valve - Simple feedback

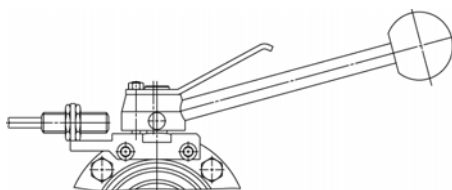

Message: Valve position "Open"

- ⇒ Inductive feedback unit
Feedback unit data - refer to data sheet of the feedback unit manufacturer.
- ⇒ Mounting kit for feedback (standard feedback unit M12)
 - DN 15 – 20 / 1/2” – 3/4” - Order No. 2304617
 - DN 25 – 40 / 1” – 1 1/2”
 - DN 15-ISO – DN 40-ISO - Order No. 2013781
 - DN 50 – 100 / 2” – 4”
 - DN 50-ISO – DN 100-ISO - Order No. 2013782

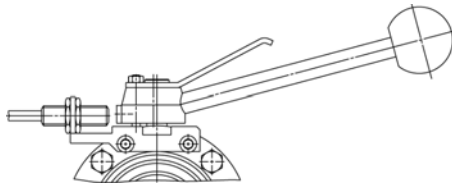

Message: Valve position "Closed"

- ⇒ Inductive feedback unit
Feedback unit data - refer to data sheet of the feedback unit manufacturer
- ⇒ Mounting kit for feedback unit (standard feedback unit M12)
 - DN 15 – 20 / 1/2” – 3/4” - Order No. 2028464
 - DN 25 – 40 / 1” – 1 1/2” - Order No. 2015101
 - 15-ISO – 40-ISO - Order No. 2015101
 - DN 50 – 100 / 2” – 4” - Order No. 2015102
 - 50-ISO – 100-ISO - Order No. 2015102

4.6.2. Manual butterfly valve - Double feedback

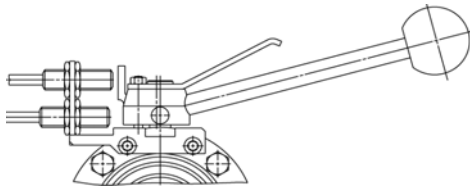

Message: Valve position "Open" and "Closed"

- ⇒ Inductive feedback unit
Feedback unit data - refer to data sheet of the feedback unit manufacturer
- ⇒ Mounting kit for feedback unit (standard feedback unit M12)
 - DN 15 – 20 / 1/2” – 3/4” - Order No. 2304618
 - DN 25 – 40 / 1” – 1 1/2” - Order No. 2013596
 - 15-ISO – 40-ISO - Order No. 2013596
 - DN 50 – 100 / 2” – 4” - Order No. 2019242
 - 50-ISO – 100-ISO - Order No. 2019242

4.6.3. Pneumatic butterfly valve - Simple feedback

Message: Valve position "Open"

Message: Valve position "Closed"

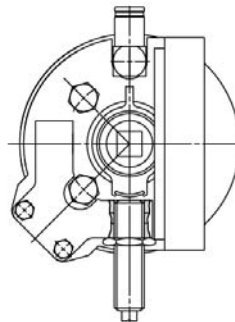
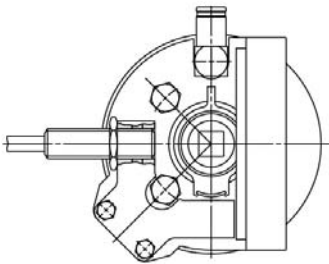

Figures: Mode of operation air to open - air to close

- ⇒ Message: Valve position "Open" or "Closed"
- ⇒ Inductive feedback unit
Feedback unit data - refer to data sheet of the feedback unit manufacturer

4.6.4. Pneumatic butterfly valve - Double feedback

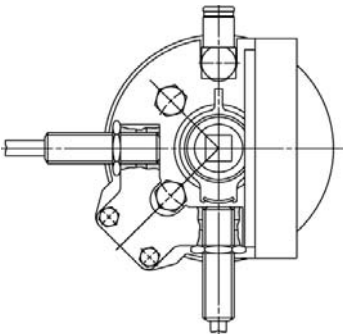

Figures: Mode of operation air to open - air to close

- ⇒ Message: Valve position "Open" and "Closed"
- ⇒ Inductive feedback unit
Feedback unit data - refer to data sheet of the feedback unit manufacturer

4.6.5. Pneumatic butterfly valve - Process control unit IntelliTop® 1.0



Technical data	see Operating Manual IntelliTop
Pneum. connections	see Operating Manual IntelliTop
Electrical connections	see Operating Manual IntelliTop
Maintenance	see Operating Manual IntelliTop

4.6.6. Pneumatic butterfly valve - Process control unit IntelliTop® 2.0



Technical data	see Operating Manual IntelliTop 2.0
Pneum. connections	see Operating Manual IntelliTop 2.0
Electrical connections	see Operating Manual IntelliTop 2.0
Maintenance	see Operating Manual IntelliTop 2.0

4.7. Electrical and pneumatic connections

4.7.1. Electrical connections

The electrical installation must be carried out, after the fitting has been installed in the system or pipeline.



Electrical installation must be carried out by skilled personnel.

Danger

- ⇒ Observe VDE-EVU and other locally applicable regulations.
- ⇒ Before connecting the unit, check whether operating voltage and current match specifications.

4.7.2. Pneumatic connections

- ⇒ Angular screw-in connection
 - Standard G 1/8, air hose PE ø6/4
 - USA G 1/8, air hose PE 1/4" (ø6,35)
- ⇒ Air hose specification - Recommendation
 - Air hose, black hose 6/4 Order No. 0490227
 - hose 8/6 Order No. 0735563
 - Material: Polyamide 12
 - Linear coefficient of expansion: 15x10⁻⁵
 - Version according to DIN 73378 soft
 - Max. operating pressure: AD 6/ ID 4 = 27 bar
 - AD 8/ ID 6 = 19 bar
 - all pressure indications at 20°C, higher temperatures have a negative effect on the max. operating pressure



- ⇒ **Use only calibrated hose pipes with an external diameter of 6 mm or 1/4" as well as 8 mm or 5/16" (tolerance +0.05/-0.1).**
- ⇒ **Cut the hose pipe only with a special hose cutter.**
- ⇒ **The length of the hose must be dimensioned in a way that prevents buckling of the hose. Even single buckling of the hose damages it permanently.**
- ⇒ **Insert the air hose into the connector and fasten it. Avoid diagonal pull on connector.**

4.8. Control air

4.8.1. Control air pressure

Pneumatic multiturn actuator	for free and unimpeded rotary movement min. 6 bars - max. 8 bars
Process control unit IntelliTop® 1.0	refer to Operating Manual IntelliTop
Process control unit IntelliTop® 2.0	refer to Operating Manual IntelliTop2.0



Make sure that the valve disk is not jammed, otherwise the butterfly valve may become damaged.

4.8.2. Control air quality

according to DIN ISO 8573.1

Solids content

Particle size	max. 5 µm
Particle density	max. 5 mg/m ³ (quality class 3)

Water content

Quality class 3

Dew point	-20° C or min. 10° C below the lowest ambient temperature
-----------	--

<u>Oil content</u>	Quality class 3, preferably oil-free, max. 25 mg of oil in 1 m ³ of air
--------------------	--



Use only clean control air according to the specification!

5. Valve function

5.1. Manual butterfly valve

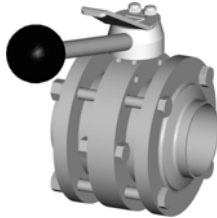

Operation: Manual - switch lever
Operating range: Locking positions at 45° and 90° for open and closed position

5.2. Pneumatic butterfly valve

Operation: Pneumatic multiturn actuator
Operating range: 90°



5.2.1. Operating mode air to open - spring to close

- ⇒ Valve position "Closed"
 - Control air pressure 0 bars to air connection A₁.
 - Safety position.
- ⇒ Valve position "Open"
 - Control air pressure 6 bars to air connection A₁.

5.2.2. Mode of operation spring to open - air to close

- ⇒ Valve position "Open"
 - Control air pressure 0 bars to air connection A₁.
 - Safety position.
- ⇒ Valve position "Closed"
 - Control air pressure 6 bars to air connection A₁.

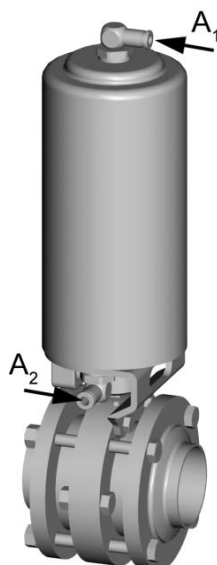

5.2.3. Mode of operation air to open - air to close

- ⇒ Valve position "Open"
 - Control air pressure 6 bars to air connection A₁.
- ⇒ Valve position "Closed"
 - Control air pressure 6 bars to air connection A₂.

5.3. Pneumatic multiturn actuator air to open - spring to close with a three-position drive

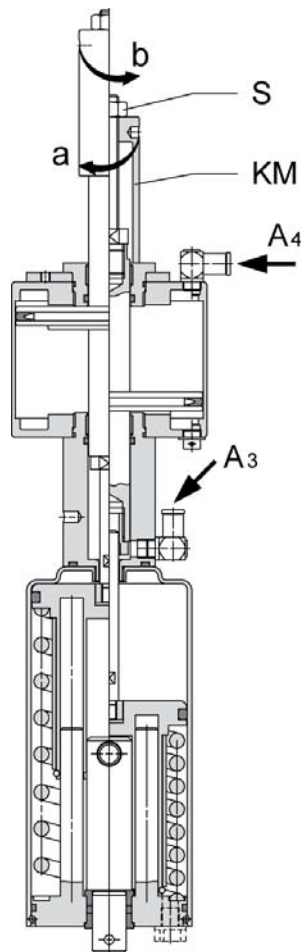

- ⇒ Position "Open"
 - Control air pressure 6 bars to connection A₃.
 - Control air pressure 0 bars to connection A₄.
- ⇒ Position "Closed"
 - Control air pressure 0 bars to connection A₃.
 - Control air pressure 0 bars to connection A₄.
- ⇒ Intermediate position
 - Control air pressure 0 bars to connection A₃.
 - Control air pressure 6 bars to connection A₄.

Setting of intermediate position

Note

Angle of rotation → 0° – 70° infinitely adjustable

- ⇒ Increasing the angle of rotation
 - Loosen the hexagon nut (S).
 - Turn the contact button (KM) in direction of the arrow **a** (clockwise).
 - Fix the set position by means of the hexagon nut (S).
- ⇒ Reducing the angle of rotation
 - Loosen the hexagon nut (S).
 - Turn the contact button (KM) in direction of the arrow **b** (counterclockwise).
 - Fix the set position by means of the hexagon nut (S).

6. Valve connection piping

6.1. Installation position

Any installation position

6.2. Valve connections

Connection options:

- Welding end
- Threaded connection
- Clamp connection
- Small flange connection

For welding instruction, please refer to chapter 7 "Welding and mounting instructions".

6.3. Mounting instructions for butterfly valves

- ⇒ Dismount the butterfly valve as specified in the mounting instructions.
- ⇒ Weld or mount the butterfly valve into the pipe.

Welding information

- ⇒ ***Dismount the seals before welding.***
- ⇒ ***Weld housing flanges and small flanges free from tension and distortions.***
- ⇒ ***Welding work must be carried out by qualified skilled personnel (DIN°287-1°W11) only.***

Mounting information

- ⇒ ***When the valves are mounted, no foreign material must remain in the pipeline.***

- ⇒ For the mounting instructions, please refer to chapter 8 "Dismounting - Mounting".

7. Welding and mounting instructions

7.1. General notes



Welding work must be carried out by qualified skilled personnel (DIN°287-1°W11) only.

Norit Südmo cannot be held liable for any damage resulting from incorrect installation.

7.2. As-delivered condition of the butterfly valve

- ⇒ Factory-tested and configured, if necessary.
- ⇒ Ready for installation or prepared for welding into the piping

7.3. Installation instructions

7.3.1. Installation space

Before starting the assembly work, determine and define the connection axes. Observe the installation dimensions specified in the dimensional drawings.

Ensure that there is sufficient space available for both operation and maintenance.

7.3.2. Installation

Make sure that the fittings and piping are not subject to any tensile or compressive stresses.

7.4. Welding directives

Field of application	Welding of fittings into pipes according to DIN 11850 series 1, 2; OD-Tube; DIN EN ISO 1127
Welding process	TIG (tungsten inert gas welding)
Type of weld seam	⇒ Preparation of weld seam acc. to DIN 2559 (edge form I / for I-seams) ⇒ weld seams correspond to DIN EN ISO 5817 → evaluation group (high)

7.5. Weld seam preparation

- ⇒ Saw off the pipe ends planar at a right angle and debur them (pipe saw M882).
- ⇒ Align the welding ends of the valve body and piping radially and axially, ensuring they are fitted flush together (centering device).



- ⇒ **Align the housing flanges according to the holes.**
- ⇒ **There must not be too much of a gap at the flush-fitting welding ends.**
- ⇒ **Make sure that enough forming gas arrives at the welding seam.**

7.6. Welding

- ⇒ Connect the forming gas.
- ⇒ Tack at 3 or 4 points.
- ⇒ Weld the valve → type of welding: TIG manual or orbital (automatic welding).

7.7. Welding filler

Material allocation

Material of parts to be welded	Suitable welding filler		
	1.4430	1.4440	1.4519
1.4404	X		
1.4435	X	X	X
1.4571	X	X	

7.8. Weld seam finishing

7.8.1. Interior

Depending on the requirement, for example

- ⇒ untreated
- ⇒ abrasive surface finishing (at accessible points).

7.8.2. Exterior

Post-treatment processes, depending on the requirement, for example

- ⇒ Pickling - Ensure proper disposal of pickling paste
- ⇒ Brushing
- ⇒ Grinding
- ⇒ Polishing

7.9. Cleaning of the valve

Clean thoroughly before assembly.

7.10. Valve assembly

Carry out the assembly according to the assembly instructions (see chapter 8 "Dismounting - Mounting").

8. Disassembly - Assembly

Assemble the butterfly valve in general after having read the safety instructions (see chapter 8.1. "Preparatory measures for dismounting - mounting").

8.1. Preparatory measures for dismounting - mounting



- ⇒ **The butterfly valves must be mounted by qualified expert personnel only.**
 - **Training or instruction in accordance with the current safety standards.**
 - **For systems with explosion protection: training or instruction or authorization to carry out work on systems subject to explosion hazards (observe ATEX regulations).**
- ⇒ **Get information on possible risks that could be caused by residues of the operating material and take appropriate measures if necessary (safety gloves, safety goggles, etc.), before carrying out maintenance and service work on the butterfly valve.**
- ⇒ **Before disconnection the valve connections and the flange connection of the valve bodies, make sure that**
 - **this work is only carried out in depressurized state and with the media supply shut off.**
 - **the butterfly valve and all piping elements leading to the valve have been drained and cleaned or flushed.**
 - **the fittings have been cooled down.**
 - **the system is not started by a third person.**
 - **the pressure build-up which may form in sealed pipelines is counteracted.**
 - **dismounting - mounting of the butterfly valve are carried out according to the mounting instructions.**
 - **the valve disk makes a rotating movement which opens or closes the passage through the valve when the drive is activated.**
 - **the power supply has been disconnected.**
 - **the butterfly valve is removed from the piping section, if possible.**

Note

- ⇒ **Cordon off mounting area.**
- ⇒ **Make sure that the mounting area remains cordoned off while work is being performed.**

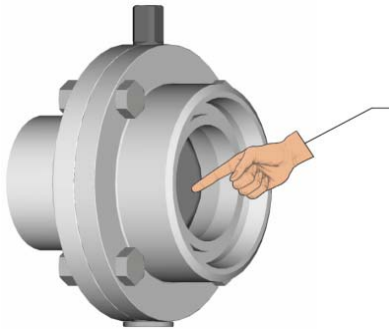

*Do not reach into the valve opening
⇒ **Danger of accident.**
Risk of limbs being crushed or cut off.*

8.2. Safety instructions regarding butterfly valves with feedback unit

8.2.1. Manual operation



*Do not reach into the feedback unit
⇒ **Danger of accident.**
Risk of limbs being crushed or cut off.*

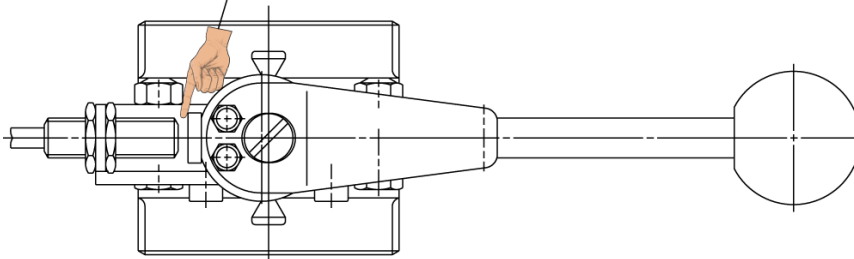

8.2.2. Pneumatic operation



*Do not reach into the feedback unit
⇒ **Danger of accident.**
Risk of limbs being crushed or cut off.*

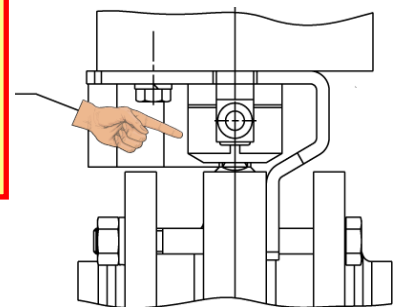

8.3. Spare parts



*Use original spare parts only.
⇒ For original spare parts, refer to the enclosed spare parts list (see chapter 13 "Spare parts list").
⇒ Perfect functioning of the butterfly valve is only guaranteed when using original spare parts.*

8.4. Disassembly and assembly of the manual butterfly valve



Avoid any damage to the metallic surfaces of the valve disks and the seal.

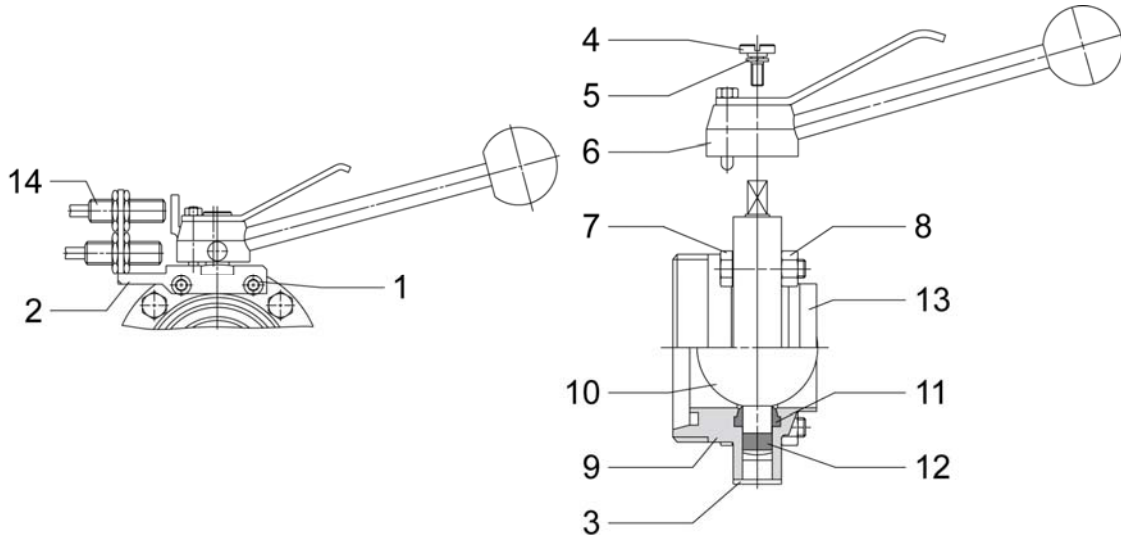

Disassembling the valve

- I.1. Disconnect the electrical leads.
- I.2. Remove the feedback unit (14) - only required for butterfly valves equipped with a feedback unit.
- I.3. Remove the feedback unit holder (2) by loosening the cap screw (1) - only required for valves equipped with a feedback unit.
- I.4. Unscrew the pipe connections and remove the butterfly valve from the piping system - the following mounting steps in the piping system have to be done for butterfly valves provided with housing flanges with welded end.
- I.5. Detach the cap screw (4) and the lock washer (5) and remove the switch lever (6).
- I.6. Loosen the hexagon nuts (8) and remove the hexagon screws (7).
- I.7. Remove the housing flange (9).
- I.8. Remove the valve disk (10) with seal (11).
- I.9. Detach the friction bearing (12).
- I.10. Remove the seal (11) from the valve disk (10) - remove it from the short shaft of the valve disk by pulling it down.

Valve assembly

- I.11. Prior to assembly, clean and grease the shafts and sliding surfaces.

Sealing materials	Grease type
EPDM	PARALIQ GTE 703
FPM	PARALIQ GTE 703
HNBR	PARALIQ GTE 703
VMQ	BARRIERTA L55/3



- ⇒ **If a different grease is used,**
- **corrosion of the sealing elements.**
- ⇒ **Do not use mineral greases and animal fat.**
- ⇒ **Do not use petroleum grease.**

- I.12. Mount the seal (11) on the valve disk (10) - see chapter 8.8 "Mounting the seal on the valve disk"
- I.13. Mount the friction bearing (12) on the valve disk (10).
- I.14. Insert the valve disk (10) with seal (11) into the housing flange (13).



Make sure that the valve disk (10) is in "Open" position when inserting it into the flange.

- I.15. Fix the housing flange (9) to the housing flange (13) by means of hexagon screws (7) and hexagon nuts (8).



Tighten the hexagon nuts (8) crosswise!

- I.16. Insert the plastic plug (3).
- I.17. Place the switch lever (6) on the valve disk (10).



**Observe the position of the switch lever (6).
⇒ Position indicator**

- I.18. Mount the cap screw (4) and the spring washer (5).
- I.19. Install the butterfly valve into the piping system by connecting the pipe connections.
- I.20. Mount the feedback unit (2) on the butterfly valve using the cap screw (1) - only required for valves equipped with a feedback unit.
- I.21. Mount the feedback unit (14) - only required for butterfly valves equipped with a feedback unit.



**After assembly, set the difference of switching of the feedback unit(s) (14).
⇒ see data sheet of the feedback unit.**

- I.22. Connect the electrical lead.

8.5. Disassembly and assembly of the manual butterfly valve - version with intermediate clamping



Caution

Avoid any damage to the metallic surfaces of the valve disks and the seal.

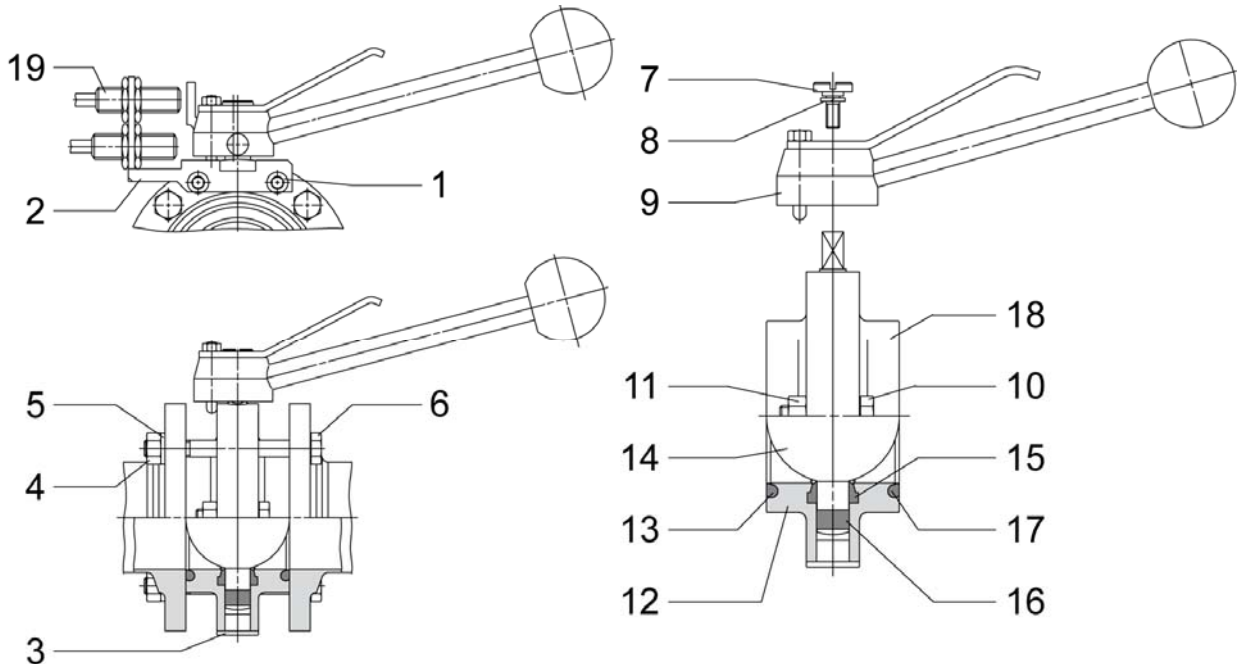

Disassembling the valve

- II.1. Disconnect the electrical leads.
- II.2. Remove the feedback unit (19) - only required for butterfly valves equipped with a feedback unit.
- II.3. Disassemble the hexagon nuts (4), lock washer (5) and hexagon screws (6) and remove the butterfly valve from the piping system.
- II.4. Remove the feedback unit holder (2) by loosening the cap screw (1) - only required for valves equipped with a feedback unit.
- II.5. Detach the cap screw (7) and the lock washer (8) and remove the switch lever (9).
- II.6. Remove the O-rings (13, 17).
- II.7. Loosen the hexagon nuts (11) and remove the hexagon screws (10).
- II.8. Remove the housing flange (13).
- II.9. Remove the valve disk (14) with seal (15).
- II.10. Detach the friction bearing (16).
- II.11. Remove the seal (15) from the valve disk (14) - first pull it over the short shaft of the valve disk

Valve assembly

- II.12. Prior to assembly, clean and grease the shafts and sliding surfaces.

Sealing materials	Grease type
EPDM	PARALIQ GTE 703
FPM	PARALIQ GTE 703
HNBR	PARALIQ GTE 703
VMQ	BARRIERTA L55/3



- ⇒ **If a different grease is used,
→ corrosion of the sealing elements.**
- ⇒ **Do not use mineral greases and animal fat.**
- ⇒ **Do not use petroleum grease.**

- II.13. Mount the seal (15) on the valve disk (14) - see chapter 8.8 "Mounting the seal on the valve disk".
II.14. Mount the friction bearing (16) on the valve disk (14).
II.15. Insert the valve disk (14) with seal (15) into the housing flange (18).



Make sure that the valve disk (14) is in "Open" position when inserting it into the flange.

- II.16. Fix the housing flange (12) on the housing flange (18) by means of hexagon screws (10) and hexagon nuts (11).



Tighten the hexagon nuts (11) crosswise!

- II.17. Insert the plastic plug (3).
II.18. Place the switch lever (9) on the valve disk (15).



**Observe the position of the switch lever (9)
⇒ Position indicator**

- II.19. Mount the cap screw (7) and the spring washer (8).
II.20. Insert the O-rings (13, 17).
II.21. Mount the feedback unit holder (2) to the butterfly valve using the cap screw (1) - only required for valves equipped with a feedback unit.
II.22. Install the butterfly valve into the piping system by means of hexagon screws (6), spring washers (5) and hexagon nuts (4).



Tighten the hexagon nuts (4) crosswise!

- II.23. Mount the feedback unit (19) - only required for butterfly valves equipped with a feedback unit.



**After assembly, set the difference of switching of the feedback unit(s) (19)
⇒ see data sheet of the feedback unit.**

- II.24. Connect the electrical lead.

8.6. Disassembly and assembly of the pneumatic butterfly valve



Caution

Avoid any damage to the metallic surfaces of the valve disks and the seal.

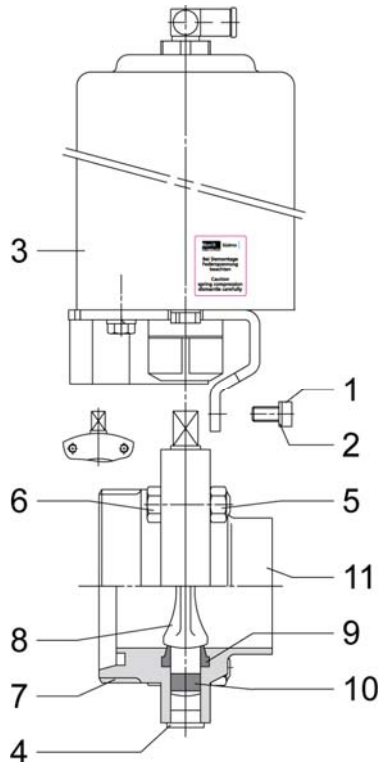

air to open - spring to close
air to open - air to close

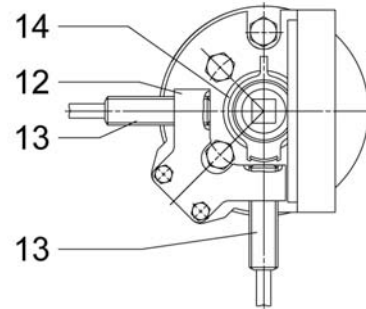

spring to open - air to close -

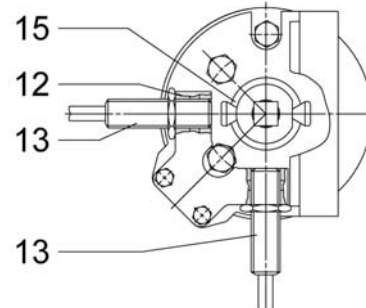

Disassembling the valve

- III.1. Disconnect the electrical and pneumatic leads.
- III.2. Detach the feedback unit (14) - only required if the feedback unit is defective.
- III.3. Unscrew the pipe connections and remove the butterfly valve from the piping system - the following mounting steps in the piping system have to be done for butterfly valves provided with housing flanges with welded end.
- III.4. Disassemble the cap screws (1) and the spring washers (2) and remove the pneumatic multiturn actuator (3).
- III.5. Loosen the hexagon nuts (5) and remove the hexagon screws (6).
- III.6. Remove the housing flange (7).
- III.7. Remove the valve disk (8) with seal (9).
- III.8. Detach the friction bearing (10).
- III.9. Remove the seal (9) from the valve disk (8) - first pull it over the short shaft of the valve disk.

Valve assembly

- III.10. Prior to assembly, clean and grease the shafts and sliding surfaces.

Sealing materials	Grease type
EPDM	PARALIQ GTE 703
FPM	PARALIQ GTE 703
HNBR	PARALIQ GTE 703
VMQ	BARRIERTA L55/3



- ⇒ **If a different grease is used,**
- **corrosion of the sealing elements.**
- ⇒ **Do not use mineral greases and animal fat.**
- ⇒ **Do not use petroleum grease.**

- III.11. Mount the seal (9) on the valve disk (8) - see chapter 8.8 "Mounting the seal on the valve disk".
 III.12. Mount the friction bearing (10) on the valve disk (8).
 III.13. Insert the valve disk (8) with seal (9) into the housing flange (11).



Make sure that the valve disk (8) is in "Open" position when inserting it into the flange.

- III.14. Fix the housing flange (7) to the housing flange (11) by means of hexagon screws (6) and hexagon nuts (5).



Tighten the hexagon nuts (5) crosswise!

- III.15. Insert the plastic plug (4).
 III.16. Set the valve disk (8) to the following positions:

Mode of operation	Valve disk position
air to open - spring to close	Closed
spring to open - air to close	Open
air to open - air to close	Closed

- III.17. Place the pneumatic multiturn actuator (3) on the valve disk (8).



Observe the position of the coupling (14) - for operating mode spring to open - air to close, a different coupling (15) is required.
 ⇒ **Position indicator**

- III.18. Mount the cap screws (1) and the spring washer (2).
 III.19. Install the butterfly valve into the piping system by connecting the pipe connections.
 III.20. Mount the feedback unit (13) in a way that it is flush with the sensor holder (12).



After assembly, set the difference of switching of the feedback unit(s) (13).

- III.21. Connect the electrical and pneumatic leads.

8.7. Disassembly and assembly of the pneumatic butterfly valve - version with intermediate clamping



Avoid any damage to the metallic surfaces of the valve disks and the seal.

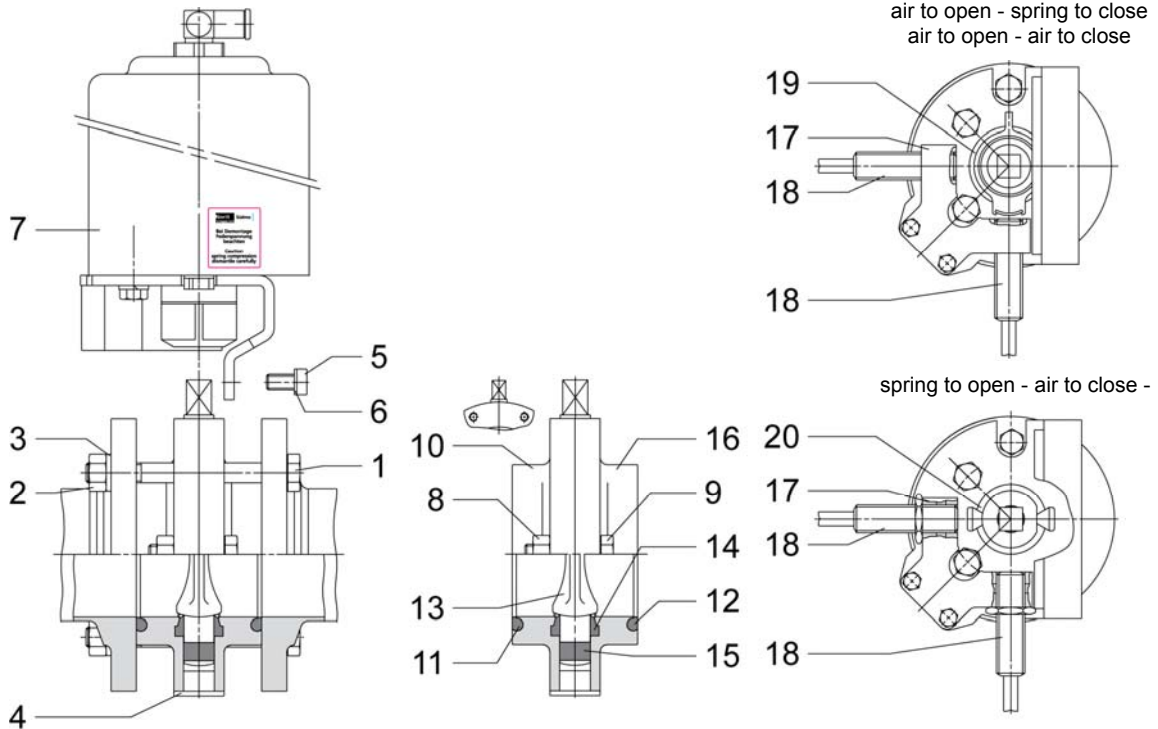

Disassembling the valve

- IV.1. Disconnect the electrical and pneumatic leads.
- IV.2. Detach the feedback unit (17) - only required if the feedback unit is defective.
- IV.3. Disassemble the hexagon nuts (2), lock washer (3) and hexagon screws (1) and remove the butterfly valve from the piping system.
- IV.4. Disassemble the cap screws (5) and the spring washer (6) and remove the pneumatic multiturn actuator (7).
- IV.5. Remove the O-rings (11, 12).
- IV.6. Loosen the hexagon nuts (8) and remove the hexagon screws (9).
- IV.7. Remove the housing flange (10).
- IV.8. Remove the valve disk (13) with seal (14).
- IV.9. Detach the friction bearing (15).
- IV.10. Remove the seal (14) from the valve disk (13) - first pull it over the short shaft of the valve disk.

Valve assembly

- IV.11. Prior to assembly, clean and grease the shafts and sliding surfaces.

Sealing materials	Grease type
EPDM	PARALIQ GTE 703
FPM	PARALIQ GTE 703
HNBR	PARALIQ GTE 703
VMQ	BARRIERTA L55/3



- ⇒ **If a different grease is used,**
→ **corrosion of the sealing elements.**
- ⇒ **Do not use mineral greases and animal fat.**
- ⇒ **Do not use petroleum grease.**

- IV.12. Install the friction bearing (15) on the valve disk (13).
 IV.13. Mount the seal (14) on the valve disk (13) - see chapter 8.8. "Mounting the seal on the valve disk".
 IV.14. Insert the valve disk (13) with seal (14) into the housing flange (16).



Make sure that the valve disk (13) is in "Open" position when inserting it into the flange.

- IV.15. Fix the housing flange (10) to the housing flange (16) by means of hexagon screws (9) and hexagon nuts (8).



Tighten the hexagon nuts (12) crosswise!

- IV.16. Remove the plastic plug (4).
 IV.17. Set the valve disk (13) to the following positions:

Mode of operation	Valve disk position
air to open - spring to close	Closed
spring to open - air to close	Open
air to open - air to close	Closed

- IV.18. Place the pneumatic multiturn actuator (3) on the valve disk (13).



Observe the position of the coupling (19) - for operating mode spring to open - air to close, a different coupling (20) is required.
 ⇒ **Position indicator**

- IV.19. Mount the cap screw (5) and the spring washer (6).
 IV.20. Insert the O-rings (11, 12).
 IV.21. Install the butterfly valve into the piping system by means of hexagon screws (1), spring washers (3) and hexagon nuts (2).



Tighten the hexagon nuts (2) crosswise!

- IV.22. Mount the feedback unit (18) and make sure that it is flush with the sensor holder (17).



After assembly, set the difference of switching of the feedback unit(s) (18).

- IV.23. Connect the electrical and pneumatic leads.

8.8. Mounting the seal on the valve disk



⇒ Insert the long shaft of the valve disk into the bore of the seal.

⇒ Deform the seal and mount it on the shaft by pulling it in the direction of the arrow **A**.



Be careful.
Avoid damaging the seal.

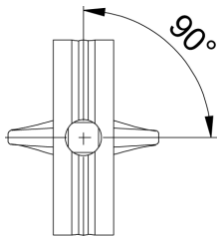
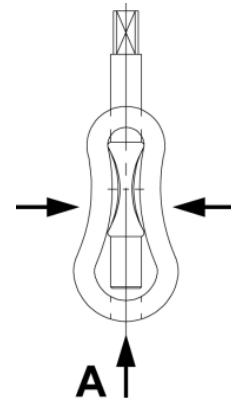

- ⇒ Position the valve disk in the seal in the "Open" position as shown on the picture.
- ⇒ Mount the valve disk.
- ⇒ Prior to mount the hand lever or the actuator, set the valve disk to the position which corresponds to the mode of operation.

8.9. Disassembly and assembly of the pneumatic multiturn actuator

8.9.1. Mode of operation air to open– spring to close, spring to open– air to close

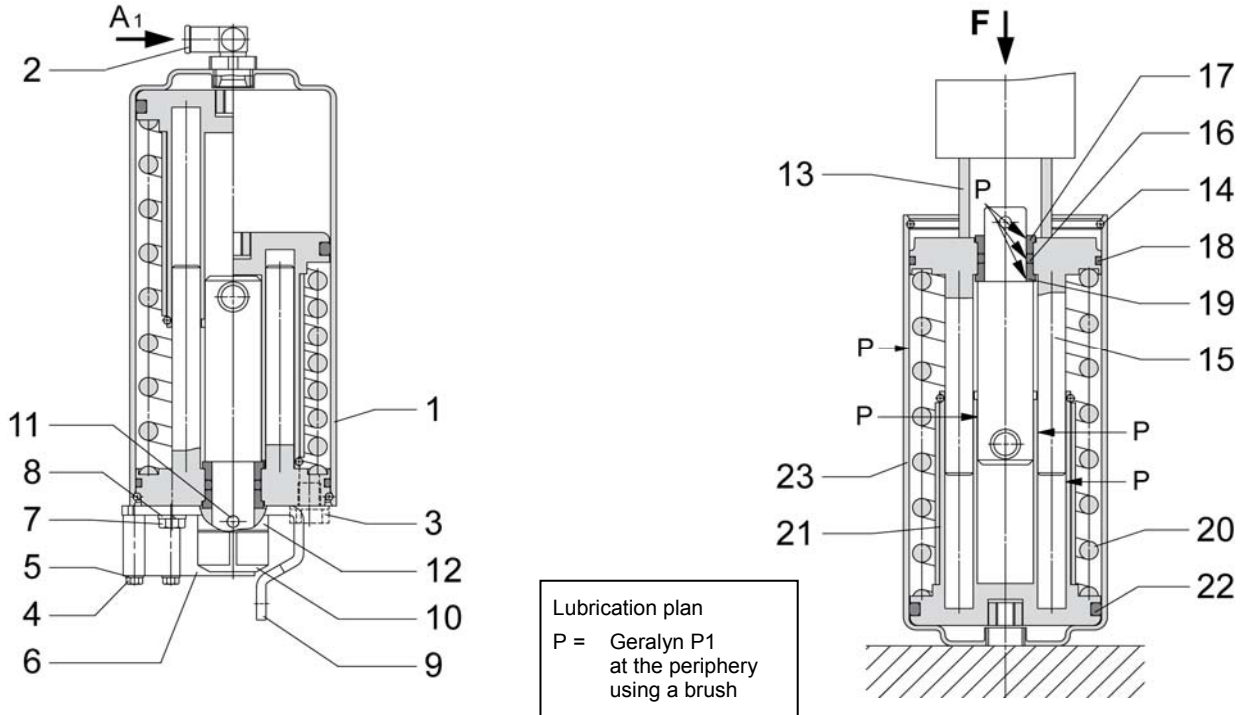

Disassembling the actuator

- V.1. Disconnect the air connection (2) and unscrew the threaded plug (3).
- V.2. Unscrew the hexagon screws (4) and remove the disks (5) and the sensor holder (6).
- V.3. Unscrew the hexagon screws (7) and remove the spring washer (8), the holder (9) and the sensor actuator (10).
- V.4. Detach the grooved taper pin (11) and remove the coupling (12).
- V.5. Position the pneumatic multiturn actuator (1) in the center of the lifting device.
- V.6. Position the spacer sleeve (13).
- V.7. Lower the plunger of the lifting device slowly onto the spacer sleeve (13). Move the spacer sleeve (13) and the cylinder base (15) with force F in the direction of the force by approx. 10 mm.
- V.8. Remove the snap ring (14).
- V.9.



Release spring force.

⇒ **Release the spring completely.**

⇒ **Provide a stroke of at least 120 mm.**

- V.10. Remove the spacer sleeve (13).
- V.11. Remove the cylinder base (15) and the O-rings (16, 18) and detach the bearings (17, 19).
- V.12. Remove the compression spring (20).
- V.13. Remove the piston package (21) and the O-ring (22).

Assembling the actuator

- V.14. Prior to assembly, clean and grease the shafts and sliding surfaces.

Sealing materials	Grease type
NBR	Geralyn P1



Caution

- ⇒ **If a different grease is used,**
- **corrosion of the sealing elements.**
- ⇒ **Do not use mineral greases and animal fat.**
- ⇒ **Do not use petroleum grease.**

- V.15. Install the O-ring (22) in the piston package (21).
- V.16. Install the O-rings (16, 18) and the bearings (17, 19) in the cylinder base (15).
- V.17. Insert the piston package (21) into the drive cylinder (23).
- V.18. Insert the compression spring (20) into the drive cylinder (23).
- V.19. Position the drive cylinder (23) in the lifting device.
- V.20. Place the cylinder base (15) on the compression spring (20) and the piston package (21).



Caution

Align the piston package (21) and the cylinder base (15).

- V.21. Position the spacer sleeve (13).
- V.22. Lower the plunger of the lifting device slowly onto the spacer sleeve (15). Move the spacer sleeve (13) and the cylinder base (15) with force F in the direction of the force by approx. 10 mm.
- V.23. Mount the snap ring (14).
- V.24.



Danger

Release spring force.

- V.25. Remove the spacer sleeve (13).
- V.26. Preload the actuator spring



Danger

⇒ **Control air pressure min. 5 bar (auxiliary assembly air) to connection A₁.**

- V.27. Place the support (9) on the pneumatic multiturn actuator and attach the coupling (12).
- V.28. Mount the sensor actuator (10) on the coupling (12) - only for mode of operation air to open - spring to close.
- V.29. Attach the coupling (12) to the pneumatic multiturn actuator by means of the grooved taper pin (11).

Make sure that the mounting position of the coupling (12) and the sensor actuator (10) is correct.



air to open - spring to close

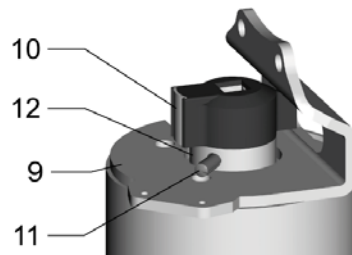

air to open - air to close

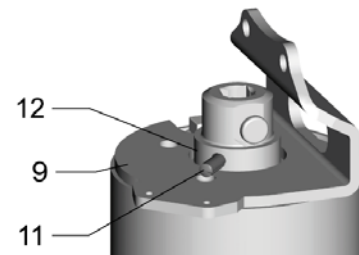

- V.30. Release the actuator spring.



Danger

- ⇒ **Control air pressure 0 bars (auxiliary assembly air) on connection A₁.**
- ⇒ **Disconnect pneumatic supply line.**

- V.31. Mount the support (9) on the cylinder base (15) by means of hexagon screws (7) and spring washers (8).
- V.32. Mount the sensor holder (6) on the support (9) by means of hexagon screws (4) and disks (5).
- V.33. Reconnect air connection (2) and the screw in the threaded plug (3).

8.9.2. Mode of operation air to open - air to close

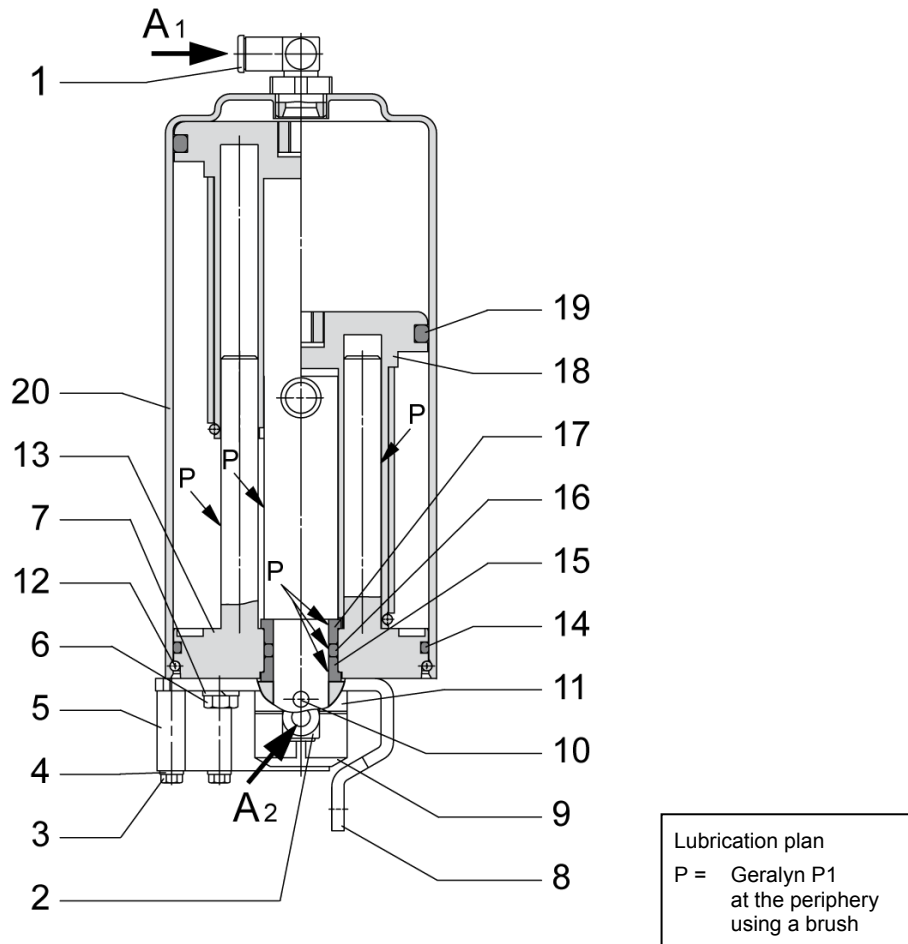

Disassembling the actuator

- VI.1. Unscrew the air connections (1, 2).
- VI.2. Unscrew the hexagon screws (3) and remove the disks (4) and the sensor holder (5).
- VI.3. Unscrew the hexagon screws (6) and remove the spring washer (7), the holder (8) and the sensor actuator (9).
- VI.4. Detach the grooved taper pin (10) and remove the coupling (11).
- VI.5. Remove the snap ring (12).
- VI.6. Remove the cylinder base (13) and the O-rings (14, 16) and detach the bearings (15, 17).
- VI.7. Remove the piston package (18) and the O-ring (19).

Assembling the actuator

- VI.8. Prior to assembly, clean and grease the shafts and sliding surfaces.

Sealing materials	Grease type
NBR	Geralyn P1



Caution

- ⇒ **If a different grease is used,
→ corrosion of the sealing elements.**
- ⇒ **Do not use mineral greases and animal fat.**
- ⇒ **Do not use petroleum grease.**

- VI.9. Install the O-ring (19) in the piston package (18).
- VI.10. Install the O-rings (14, 16) and the bearings (15, 17) in the cylinder base (13).
- VI.11. Insert the piston package (18) into the drive cylinder (20).
- VI.12. Insert the cylinder base (13) in the drive cylinder (20).



Caution

Align the piston package (18) and the cylinder base (13).

- VI.13. Mount the snap ring (12).
- VI.14. Preload the actuator spring



Danger

⇒ Control air pressure min. 5 bar (auxiliary assembly air) to connection A1

- VI.15. Place the support (8) on the pneumatic multiturn actuator and attach the coupling (11).
- VI.16. Mount the sensor actuator (9) on the coupling (11).
- VI.17. Attach the coupling (11) to the pneumatic multiturn actuator by means of the grooved taper pin (10).



Make sure that the mounting position of the coupling (11) and the sensor actuator (9) is correct.

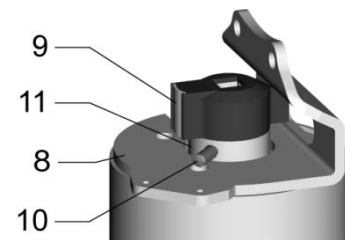

- VI.18. Release the actuator spring.



Danger

- ⇒ **Control air pressure 0 bars (auxiliary assembly air) on connection A1.**
- ⇒ **Disconnect pneumatic supply line.**

- VI.19. Mount the support (8) on the cylinder base (13) by means of hexagon screws (6) and spring washers (7).
- VI.20. Mount the sensor holder (5) on the support (8) by means of hexagon screws (3) and disks (2).
- VI.21. Install the air connections (1, 2).

8.10. Assembling and disassembling the pneumatic multiturn actuator with a three-position drive

8.10.1. Subsequent installation of the three-position drive

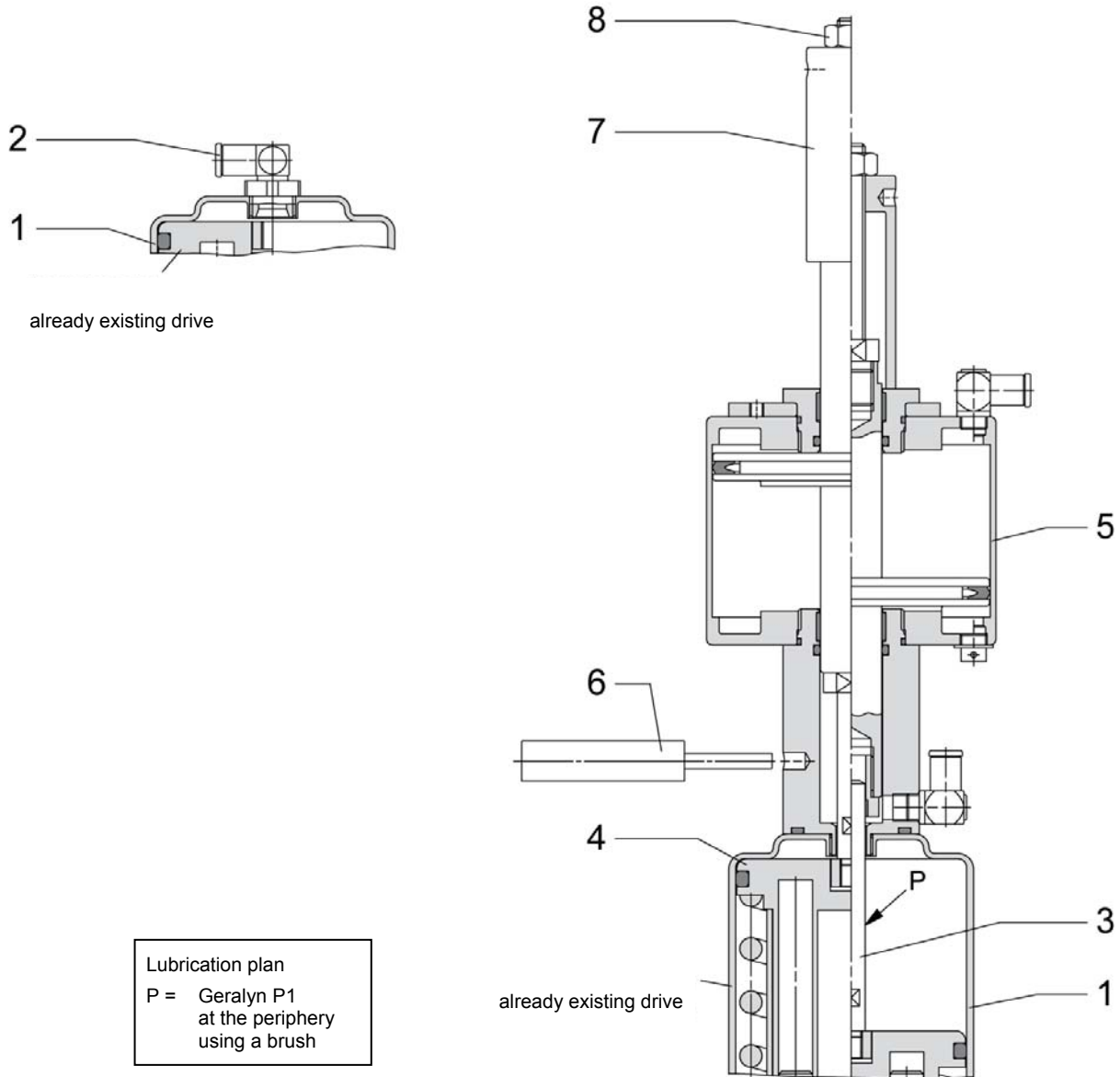

- VII.1. Prior to assembly, clean and grease the shafts and sliding surfaces.
- VII.2. Disconnect the air connection (2).
- VII.3. Screw the spindle (3) on the piston of the multiturn actuator (4).
- VII.4. Fix the three-position drive (5) on the multiturn actuator (1).
- VII.5. Adjust the angle of rotation by rotating the stop (6). After adjustment, fix the set position by means of the hexagon nut (7).

8.10.2. Replacing the seal of the three-position drive

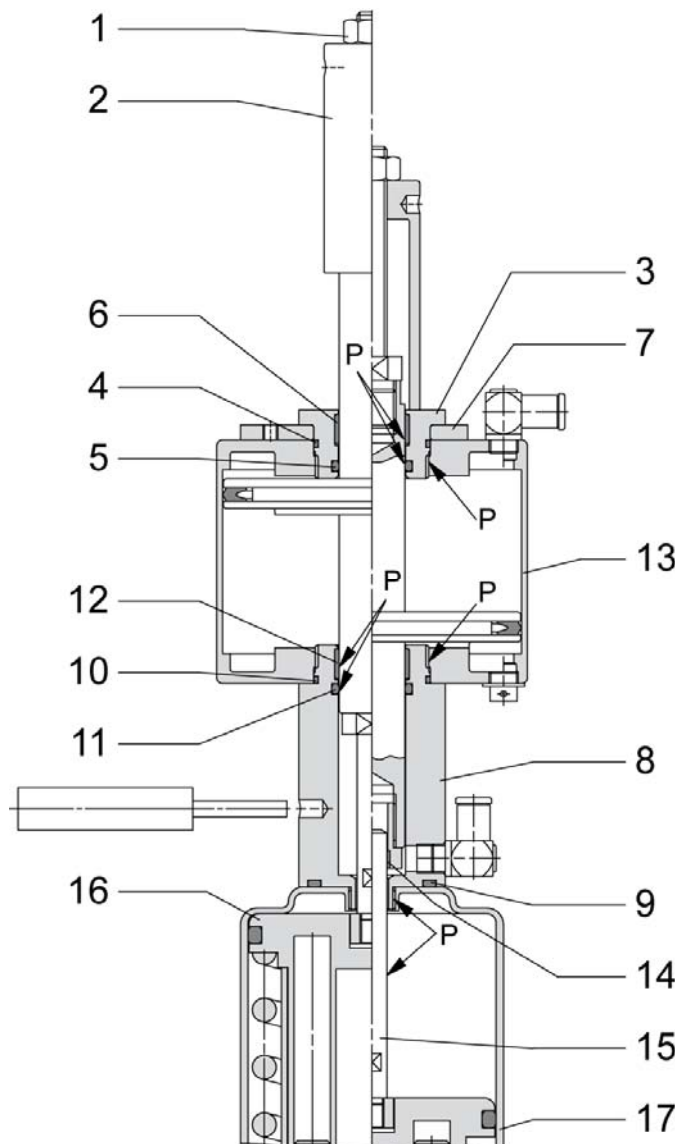

Disassembling the actuator

- VIII.1. Dismount the stop (2) and the hexagon nut (1).
- VIII.2. Dismount the three-position drive (13) with hub flange (8) from the pneumatic multiturn actuator (17).
- VIII.3. Unscrew the locking screw (3) and remove O-rings (4, 5) and friction bearing (6).
- VIII.4. Remove the adapter disk (7).
- VIII.5. Unscrew the hub flange (8) and remove the O-rings (9, 10, 11) and the friction bearing (12).
- VIII.6. Remove the spindle (15) - only required if the multiturn actuator seal has to be replaced.

Assembling the actuator

- VIII.7. Prior to assembly, clean and grease the shafts and sliding surfaces.

Sealing materials	Grease type
NBR	Geralyn P1



- ⇒ **If a different grease is used,**
→ **corrosion of the sealing elements.**
- ⇒ **Do not use mineral greases and animal fat.**
- ⇒ **Do not use petroleum grease.**

- VIII.8. Screw the spindle (15) on the piston of the multiturn actuator (16).
- VIII.9. Install the O-rings (9, 10, 11) and the friction bearings (12) in the hub flange (8).
- VIII.10. Mount the hub flange (8) on the three-position drive (13).
- VIII.11. Install the O-rings (4, 5) and the friction bearings (6) in the locking screw (3).
- VIII.12. Place the adapter disk (7) on the three-position drive (13) and mount the locking screw (3).
- VIII.13. Fix the three-position drive (13) on the multiturn actuator (17).
- VIII.14. Attach the stops (2) and the hexagon nut (1).
- VIII.15. Adjust the angle of rotation by rotating the stop (2). After adjustment, fix the set position by means of the hexagon nut (1).

8.11. Installation of the process control unit IntelliTop® on the pneumatic multiturn actuator

8.11.1. Process control unit IntelliTop® 1.0

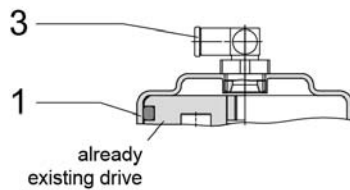

Lubrication plan
P = Geralyn P1
at the periphery
using a brush

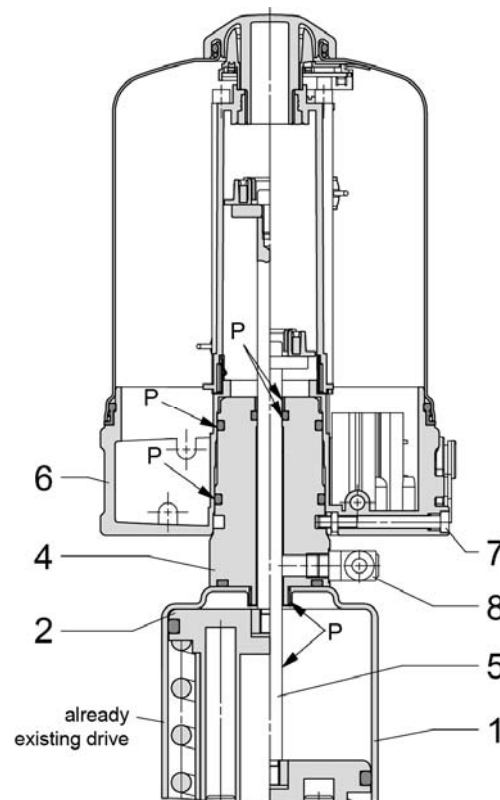

Disassembling the control unit

- IX.1. Disassemble the air connection (3) - only required in case of a subsequent installation of the process control unit
- IX.2. Unscrew the cap screw (7).
- IX.3. Remove the process control unit (6) from the adapter (4).
- IX.4. Remove the adapter (4).
- IX.5. Remove the contact button (5).

Assembling the control unit

- IX.6. Prior to assembly, clean and grease the shafts and sliding surfaces. Grease the sealing elements before installation.
- IX.7. Disconnect the air connection (3).
- IX.8. Install the adapter (4) on the pneumatic multiturn actuator (1).
- IX.9. Screw the contact button (5) on the piston of the multiturn actuator (2).
- IX.10. Plug the process control unit (6) onto the adapter (4).
- IX.11. Screw on the cap screw (7).
- IX.12. Reconnect the air connection (8).

8.11.2. Process control unit IntelliTop® 2.0

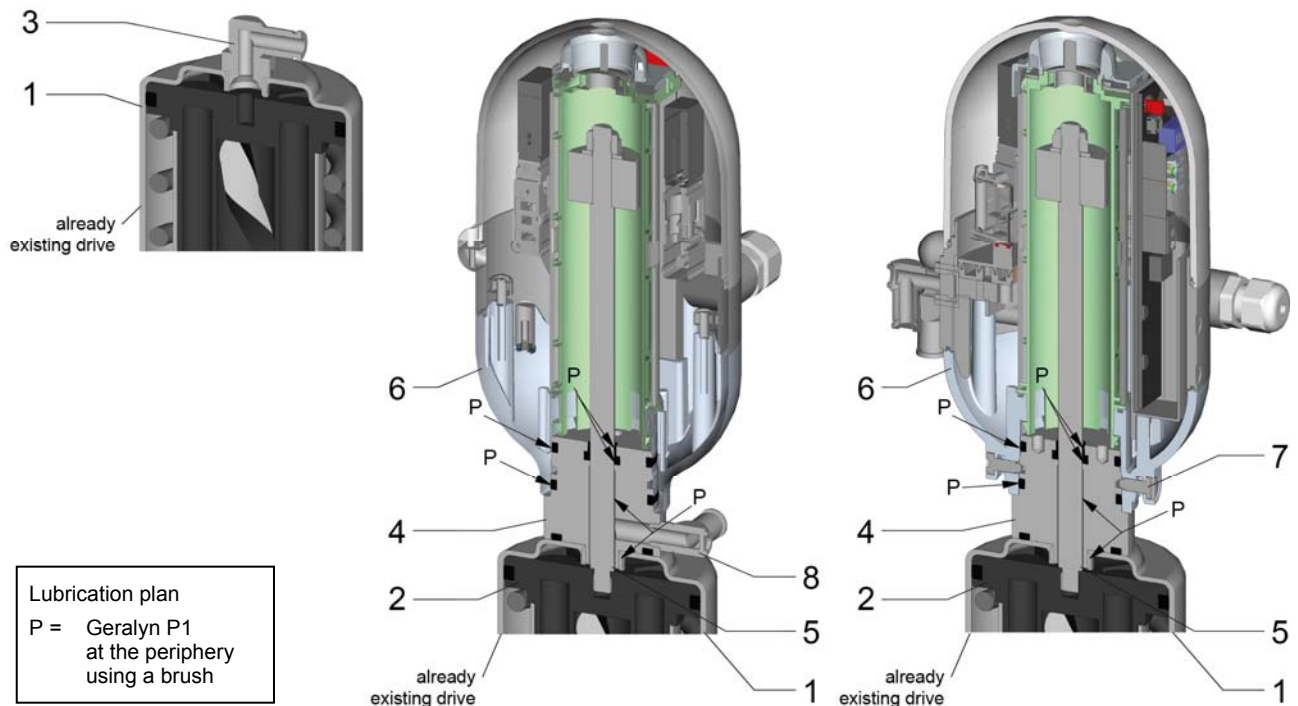

Disassembling the control unit

- X.1. Disconnect the air connection (3).
- X.2. Unscrew the cap screw (7).
- X.3. Remove the process control unit (6) from the adapter (4).
- X.4. Unscrew the contact button (5).
- X.5. Remove the adapter (4).

Assembling the control unit

- X.6. Prior to assembly, clean and grease the shafts and sliding surfaces. Grease the sealing elements before installation.
- X.7. Disassemble the air connection (3) - only required in case of a subsequent installation of the process control unit
- X.8. Install the adapter (4) on the pneumatic multiturn actuator (1).
- X.9. Screw the contact button (5) on the piston of the multiturn actuator (2).
- X.10. Plug the process control unit (6) onto the adapter (4).
- X.11. Screw on the cap screw (7).
- X.12. Reconnect the air connection (8).

9. Putting the butterfly valve into operation



- ⇒ *Ensure that no foreign objects are present in the piping system.*
- ⇒ *Avoid temperature shock!*
- ⇒ *Warm up the fitting slowly to the operating temperature.*

9.1. Functional check of the butterfly valve

9.1.1. Manual operation

Switch the valve by means of the switch lever.

Before start-up of the butterfly valve, the valve must be cleaned.

9.1.2. Pneumatic operation

Switch the valve several times by activation with compressed air.

Before start-up of the butterfly valve, the valve must be cleaned.

9.2. Tightness test of the butterfly valve

Check visually if the seals have any leaks.

Replace defective seals.

10. Maintenance of butterfly valve

10.1. Preparatory maintenance measures



- ⇒ *The butterfly valves must be mounted by qualified expert personnel only.*
 - *Training or instruction in accordance with the current safety standards.*
 - *For systems with explosion protection: training or instruction or authorization to carry out work on systems subject to explosion hazards (observe ATEX regulations).*
- ⇒ *Get information on possible risks that could be caused by residues of the operating material and take appropriate measures if necessary (safety gloves, safety goggles, etc.), before carrying out maintenance and service work on the butterfly valve.*
- ⇒ *Before disconnection the valve connections and the flange connection of the valve bodies, make sure that*
 - *this work is only carried out in depressurized state and with the media supply shut off.*
 - *the butterfly valve and all piping elements leading to the valve have been drained and cleaned or flushed.*
 - *the fittings have been cooled down.*
 - *the system is not started by a third person.*
 - *the pressure build-up which may form in sealed pipelines is counteracted.*



- *dismounting - mounting of the butterfly valve are carried out according to the mounting instructions (see chapter 8 "Dismounting - Mounting").*
- *the valve disk makes a rotating movement which opens or closes the passage through the valve when the drive is activated.*
- *the power supply has been disconnected.*
- *the butterfly valve is removed from the piping section, if possible.*

Note

- ⇒ *Cordon off mounting area.*
- ⇒ *Make sure that the mounting area remains cordoned off while work is being performed.*

10.2. Inspection of the butterfly valve

Butterfly valves have to be checked and, if necessary, serviced at regular intervals.

10.3. Maintenance of the butterfly valve

Practice-oriented maintenance intervals can only be determined by the respective user/operator as they depend on the following application parameters:

- ⇒ Operating time per day
- ⇒ Number of switching intervals
- ⇒ Type of product
- ⇒ Type of cleaning (CIP / SIP)

Maintenance recommendation (for orientation):

- ⇒ for liquids with solid particles and temperatures of 80° C to 100° C approx. every 3-6 months
- ⇒ for liquids with solid particles and temperatures of 60° C every 12 months
- ⇒ for liquids without solid particles and temperatures of max. 60° C every 24 months.

Intervals of 12 months are recommended for cleaning systems.

Of course, the intervals stated above require sufficient chemical resistance of the sealing materials.

11. Malfunctions - Troubleshooting



- ⇒ **In case of malfunctions, immediately shut off the valve and secure it against restart.**
- ⇒ **Malfunctions must be eliminated by qualified and trained personnel only while observing the safety instructions.**



- ⇒ **Never touch the valve or the pipelines if hot media are processed or if the sterilizing process is running.**
- ⇒ **Always adhere exactly to the operating parameters (see chapter 4 "Technical Data").**

Malfunction	Cause	Troubleshooting
Switching function disturbed	⇒ Fault in the control system	⇒ Check the system configuration
	⇒ No compressed air	⇒ Check compressed air supply
	⇒ Compressed air level is too low	⇒ Check if air hoses are free and tight
	⇒ Fault in the electrical system	⇒ Check activation / process control unit and electrical lines
	⇒ Pilot valve is defective	⇒ Replace the pilot valve
Air escapes from the actuator	⇒ Seals in the actuator are defective	⇒ Replace the seals
Valve does not close	⇒ Dirt / foreign objects between valve disk and seal	⇒ Clean the valve body and the sealing area between valve disk / seal.
	⇒ Seal has swelled	⇒ Replace the seal
	⇒ Valve disk is bent due to outside influences	⇒ Replace the valve disk
Valve closes too slowly	⇒ Seals in the multiturn actuator are dry (friction losses)	⇒ Grease the seals
Valve is leaky	⇒ Seals are worn	⇒ Replace the seals
	⇒ Seal sheared off	⇒ Check the system parameters, e.g. <ul style="list-style-type: none"> - pressure pulses - is the pump switched-off in time - flow parameter - subsequent installation of air throttle

12. Disposal

- ⇒ Dismount the butterfly valve in accordance with the mounting instructions (see chapter 8 "Dismounting - Mounting").
- ⇒ Dispose of the butterfly valve in accordance with the local regulations of the country of destination.

13. Spare parts list

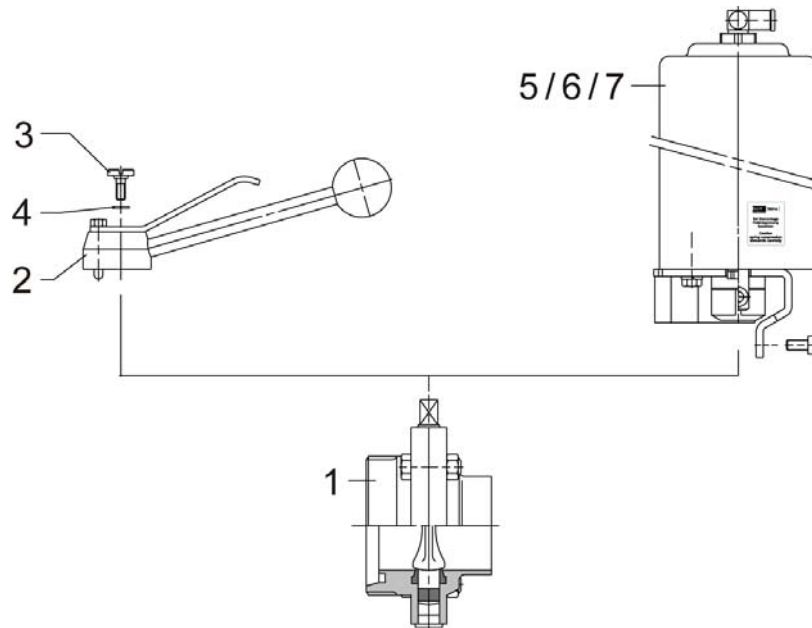

Pos.	Quantity	Designation	Order No.:	Order No.:	Order No.
Metric design - Butterfly valve for pipe connection according to DIN 11850			DN 15 – 20	DN 25 – 40	DN 50 – 100
Design based on inch-system - Butterfly valve for pipe connections according to DIN 11866			DN 1/2” – 3/4”	DN 1” – 1 1/2”	DN 2” – 4”
1	1	Butterfly valve	see page 44 - 48	see page 44 - 48	see page 44 - 48
2	1	Switch lever	2124249	2124249	2124222
3	1	Cap screw	0366393	0366393	0366393
4	1	Spring washer	0837807	0837807	0837807
5	1	Pneumatic multiturn actuator air to open - spring to close	2701900 2705210 (USA)	2701901 2705211 (USA)	2701902 2705212 (USA)
6	1	Pneumatic multiturn actuator spring to open - air to close	2705109	2705104	2705105
7	1	Pneumatic multiturn actuator air to open - air to close	2701903 2705381 (USA)	2701904 2705382 (USA)	2701905 2705383 (USA)
ISO design - Butterfly valve for pipe connection according to DIN EN ISO 1127			DN 15-ISO - 40-ISO	DN 50-ISO - 100-ISO	
1	1	Butterfly valve	see page 44 - 48	see page 44 - 48	
2	1	Switch lever	2124249	2124222	
3	1	Cap screw	0366393	0366393	
4	1	Spring washer	0837807	0837807	
5	1	Pneumatic multiturn actuator air to open - spring to close	2701901 2705211 (USA)	2701902 2705212 (USA)	
6	1	Pneumatic multiturn actuator spring to open - air to close	2705104	2705105	
7	1	Pneumatic multiturn actuator air to open - air to close	2701904 2705382 (USA)	2701905 2705383 (USA)	

13.1. Butterfly valve

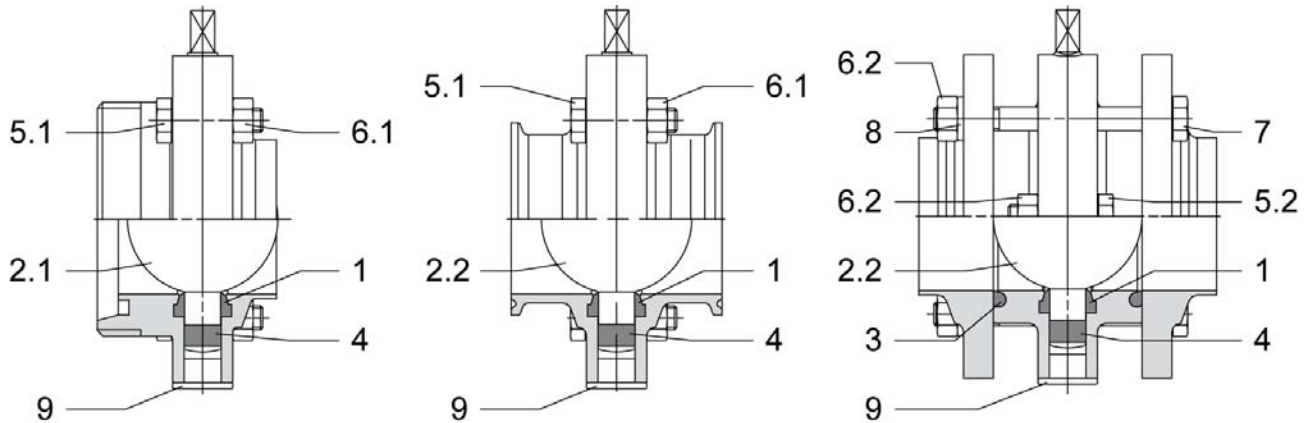

Pos.	Quantity	Designation	Material	Order No.	Order No.	Order No.
Metric design - Butterfly valve for pipe connection according to DIN 11850				DN 15	DN 20	DN 25
1	1	Seal *	EPDM	S0000093	S0000093	S0005031
			VMQ	S0000080	S0000080	S0000073
			FPM	S0000106	S0000106	S0000099
			HNBR	S0001959	S0001959	S0001950
2.1	1	Valve disk	1.4404	S0000441	S0000439	S0000114
2.2	1	Valve disk	1.4404	S0000441	S0000441	S0000114
3	2	O-ring *	EPDM	2912860	2912861	2912862
			VMQ	0962258	0962266	0497925
			FPM	2101379	2101378	2101377
			HNBR	2101602	2101603	2101604
4	1 2 DN 25	Bearing shell	IGLIDUR	S0000443	S0000443	S0000443
5.1	4	Hexagon screw	A 2-70	0744557	0744557	0011528
5.2	2	Hexagon screw	A 2-70	0744557	0744557	0011528
6.1	4	Hexagon nut	A 2-70	0165191	0165191	S0000061
6.2	6	Hexagon nut	A 2-70	0165191	0165191	S0000061
7	4	Hexagon screw	A 2-70	0780981	0780981	0780999
8	4	Spring washer	A 2	0949750	0949750	0837807
9	1	Plastic plug	PE	0108464	0108464	0108464

* = Please specify the sealing material on order!

Pos.	Quantity	Designation	Material	Order No.	Order No.	Order No.
Metric design - Butterfly valve for pipe connection according to DIN 11850				DN 32	DN 40	DN 50
1	1	Seal *	EPDM	S0005032	S0005033	S0005034
			VMQ	S0000074	S0000075	S0000076
			FPM	S0000100	S0000101	S0000102
			HNBR	S0001951	S0001952	S0001953
2.1 2.2	1	Valve disk	1.4404	S0000462	S0000160	S0000161
3	2	O-ring *	EPDM	0961235	2912864	2912865
			VMQ	0544130	2101397	2101398
			FPM	2101376	2101375	2101374
			HNBR	2101605	2101607	2101606
4	2	Bearing shell	IGLIDUR	S0000443	S0000443	S0000444
5.1	4	Hexagon screw	A 2-70	0011528		
5.2	2	Hexagon nut	A 2-70	0011528	0011528	0011528
6.1	4	Hexagon nut	A 2-70	S0000061		
6.2	6	Hexagon screw	A 2-70	S0000061	S0000061	S0000061
7	4	Spring washer	A 2-70	0780999	0780999	0780999
8	4	Plastic plug	A 2	0837807	0837807	0837807
9	1	Plastic plug	PE	0108464	0108464	0108472
Metric design - Butterfly valve for pipe connection according to DIN 11850				DN 65	DN 80	DN 100
1	1	Seal *	EPDM	S0005035	S0005022	S0005036
			VMQ	S0000077	S0000078	S0000079
			FPM	S0000103	S0000104	S0000105
			HNBR	S0001954	S0001955	S0001956
2.1 2.2	1	Valve disk	1.4404	S0000465	S0000163	S0000164
3	2	O-ring *	EPDM	2912866	2912867	2912868
			VMQ	0544171	0962274	0962282
			FPM	2101373	2101372	2101371
			HNBR	2101608	2101609	2101610
4	2	Bearing shell	IGLIDUR	S0000444	S0000444	S0000445
5.1	4	Hexagon screw	A 2-70	0011528	0011528	0011528
	6 DN 100					
5.2	2	Hexagon screw	A 2-70	0011528	0011528	0011528
	4 DN 100					
6.1	4	Hexagon nut	A 2-70	S0000061	S0000061	S0000061
	6 DN 100					
6.2	6	Hexagon nut	A 2-70	S0000061	S0000061	S0000061
	10 DN 100					
7	4	Hexagon screw	A 2-70	0780999	0780999	0780999
	6 DN 100					
8	4	Spring washer	A 2	0837807	0837807	0837807
	6 DN 100					
9	1	Plastic plug	PE	0108472	0108472	0108480

* = Please specify the sealing material on order!

Pos.	Quantity	Designation	Material	Order No.	Order No.	Order No.
Design based on inch-system - Butterfly valve for pipe connections according to DIN 11866				DN 1/2”	DN 3/4”	DN 1”
1	1	Seal *	EPDM	S0000093	S0000093	S0000093
			VMQ	S0000080	S0000080	S0000080
			FPM	S0000106	S0000106	S0000106
			HNBR	S0001959	S0001959	S0001959
2.1	1	Valve disk	1.4404	S0000441	S0000439	S0000467
2.2	1	Valve disk	1.4404	S0000441	S0000441	S0000467
3	2	O-ring *	EPDM	2912860	2912861	2912889
			VMQ	0962258	0962266	2101402
			FPM	2101379	2101378	2101386
			HNBR	2101602	2101603	2003749
4	1	Bearing shell	IGLIDUR	S0000443	S0000443	S0000443
5.1	4	Hexagon screw	A 2-70	0744557	0744557	0011528
5.2	2	Hexagon screw	A 2-70	0744557	0744557	0011528
6.1	4	Hexagon nut	A 2-70	0165191	0165191	S0000061
6.2	6	Hexagon nut	A 2-70	0165191	0165191	S0000061
7	4	Hexagon screw	A 2-70	0780981	0780981	0780999
8	4	Spring washer	A 2	0949750	0949750	0837807
9	1	Plastic plug	PE	0108464	0108464	0108464
Design based on inch-system - Butterfly valve for pipe connections according to DIN 11866				DN 1 1/2”	DN 2”	DN 2 1/2”
1	1	Seal *	EPDM	S0000094	S0000095	S0005042
			VMQ	S0000081	S0000082	S0000083
			FPM	S0000107	S0000108	S0000109
			HNBR	S0001960	S0001961	S0001962
2.1	1	Valve disk	1.4404	S0000468	S0000469	S0000470
2.2						
3	2	O-ring *	EPDM	2912890	2912891	2159465
			VMQ	2101403	2101404	2101401
			FPM	2101385	2101384	2101383
			HNBR	2101613	2003751	2101614
4	2	Bearing shell	IGLIDUR	S0000443	S0000444	S0000444
5.1	4	Hexagon screw	A 2-70	0011528	0011528	0011528
5.2	2	Hexagon screw	A 2-70	0011528	0011528	0011528
6.1	4	Hexagon nut	A 2-70	S0000061	S0000061	S0000061
6.2	6	Hexagon nut	A 2-70	S0000061	S0000061	S0000061
7	4	Hexagon screw	A 2-70	0780999	0780999	0780999
8	4	Spring washer	A 2	0837807	0837807	0837807
9	1	Plastic plug	PE	0108464	0108472	0108472

* = Please specify the sealing material on order!

Pos.	Quantity	Designation	Material	Order No.	Order No.	Order No.
Design based on inch-system - Butterfly valve for pipe connections according to DIN 11866				DN 3"	DN 4"	
1	1	Seal *	EPDM	S0005043	S0005044	
			VMQ	S0000084	S0000085	
			FPM	S0000110	S0000111	
			HNBR	S0001963	S0001964	
2.1 2.2	1	Valve disk	1.4404	S0000471	S0000472	
3	2	O-ring *	EPDM	2912893	2159455	
			VMQ	2101400	2101399	
			FPM	2101382	2101381	
			HNBR	2101615	2101616	
4	2	Bearing shell	IGLIDUR	S0000444	S0000445	
5.1 4 DN 4"	2	Hexagon screw	A 2-70	0011528	0011528	
5.2 4 DN 4"	2	Hexagon screw	A 2-70	0011528	0011528	
6.1 10 DN 4"	6	Hexagon nut	A 2-70	S0000061	S0000061	
6.2 10 DN 4"	6	Hexagon nut	A 2-70	S0000061	S0000061	
7 6 DN 4"	4	Hexagon screw	A 2-70	0780999	0780999	
8 6 DN 4"	4	Spring washer	A 2	0837807	0837807	
9	1	Plastic plug	PE	0108472	0108480	
ISO design - Butterfly valve for pipe connection according to DIN EN ISO 1127				DN 15-ISO	DN 20-ISO	DN 25-ISO
1	1	Seal	EPDM		S0000093	S0005026
2.1 2.2	1	Valve disk	1.4404		S0000467	2128610
3	2	O-ring *	EPDM		2912889	0911404
4 2 DN 25-ISO	1	Bearing shell	IGLIDUR		S0000443	S0000443
5	2	Hexagon screw	A 2-70		0011528	0011528
6	6	Hexagon nut	A 2-70		S0000061	S0000061
7	4	Hexagon screw	A 2-70		0780999	0780999
8	4	Spring washer	A 2		0837807	0837807
9	1	Plastic plug	PE		0108464	0108464

* = Please specify the sealing material on order!

Pos.	Quantity	Designation	Material	Order No.	Order No.	Order No.
ISO design - Butterfly valve for pipe connection according to DIN EN ISO 1127				DN 32-ISO	DN 40-ISO	DN 50-ISO
1	1	Seal	EPDM	S0005023	S0005027	S0005028
2.1 2.2	1	Valve disk	1.4404	S0000160	2128611	2128609
3	2	O-ring	EPDM	2912864	2159456	2159393
4	2	Bearing shell	IGLIDUR	S0000443	S0000443	S0000444
5	2	Hexagon screw	A 2-70	0011528	0011528	0011528
6	6	Hexagon nut	A 2-70	S0000061	S0000061	S0000061
7	4	Hexagon screw	A 2-70	0780999	0780999	0780999
8	4	Spring washer	A 2	0837807	0837807	0837807
9	1	Plastic plug	PE	0108464	0108464	0108472
ISO design - Butterfly valve for pipe connection according to DIN EN ISO 1127				DN 65-ISO	DN 80-ISO	DN 100-ISO
1	1	Seal	EPDM	S0005024	S0005029	S0005030
2.1 2.2	1	Valve disk	1.4404	S0000471	2128613	2128614
3	2	O-ring *	EPDM	0963066	2159458	2107154
4	2	Bearing shell	IGLIDUR	S0000444	S0000444	S0000445
5	2	Hexagon screw	A 2-70	0011528	0011528	0011528
6	10	Hexagon nut	A 2-70	S0000061	S0000061	S0000061
7	6	Hexagon screw	A 2-70	0780999	0780999	0780999
8	4	Spring washer	A 2	0837807	0837807	0837807
9	1	Plastic plug	PE	0108472	0108472	0108480

* = Please specify the sealing material on order!

13.2. Pneumatic multiturn actuator DN 15 – 100, DN 1/2" – 4", DN 15-ISO – DN 100-ISO

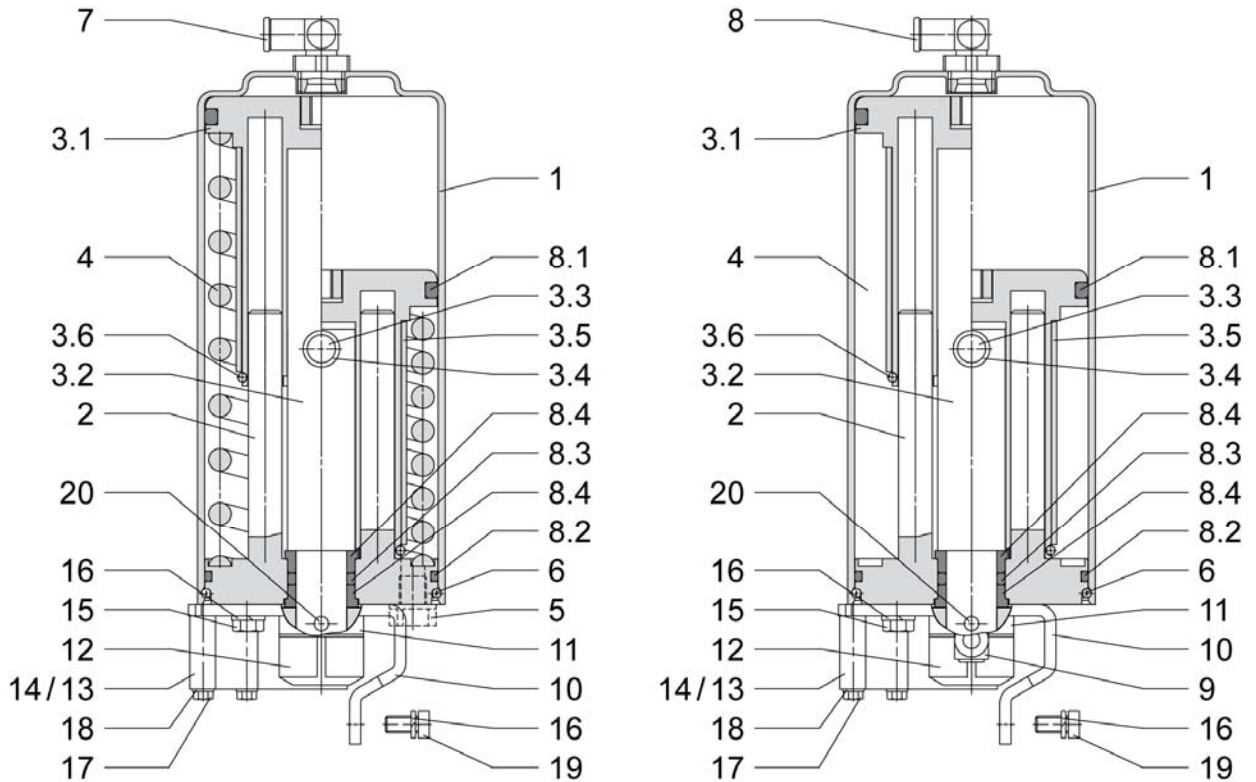

Pos.	Quantity	Designation	Material	Order No.	Order No.	Order No.
				Mode of operation air to open - spring to close	Mode of operation spring to open - air to close	Mode of operation air to open - air to close
1	1	Cylinder	1.4301	2142944	2142944	2142944
2	1	Cylinder base	1.4301	2700803	2700803	2700803
3	1	Piston assembly		2707003	2707003	2707003
3.1	1	Piston	POM			
3.2	1	Shaft	1.4122			
3.3	1	Shaft	1.4122			
3.4	2	Ball race	1.4034			
3.5	1	Pipe	1.4301			
3.6	1	Snap ring	1.4310			
4	1	Compression spring	SiCr	2150721	2150721	-----
5	1	Threaded plug	HD-PE	2102450	2102450	-----
6	1	Snap ring	1.4310	2131783	2131783	2131783
7	1	Angular screw-in connection		2101683	2101683	2101683
8	1	Complete set of seals		2703021	2703021	2703021
8.1	1	O-ring	NBR	2105734	2105734	2105734
8.2	1	O-ring	NBR	0924381	0924381	0924381
8.3	1	O-ring	NBR	0925065	0925065	0925065
8.4	2	Bushing	Iglicur	2150588	2150588	2150588

Pos.	Quantity	Designation	Material	Order No.	Order No.	Order No.
				Mode of operation air to open - spring to close	Mode of operation spring to open - air to close	Mode of operation air to open - air to close
9	1	Angular screw-in connection		-----	-----	2116513
10	1	Support				
		DN 15 - 20	1.4301	S0000820	S0000820	S0000820
		DN 25 – 40 / 1” – 1 ½” DN 15-ISO – 40-ISO	1.4301	S0000252	S0000252	S0000252
		DN 50 – 100 / 2” – 4” DN 50-ISO – 100-ISO	1.4301	S0000251	S0000251	S0000251
11	1	Coupling				
		DN 15 - 20	1.4301	2143251	2143249	2143251
		DN 25 – 40 / 1” – 1 ½” DN 15-ISO – 40-ISO	1.4301	2143250	2143249	2143250
		DN 50 – 100 / 2” – 4” DN 50-ISO – 100-ISO	1.4301	2153994	2143248	2153994
12	1	Sensor actuator		S0000849	-----	S0000849
13	1	Hexagon nut	1.4301	S0001883	S0001883	S0001883
14	1	Sensor holder		S0000851	S0000851	S0000851
15	2	Hexagon screw	A 2-70	2103098	2103098	2103098
16	4	Spring washer	A 2	0939843	0939843	0939843
17	2	Hexagon screw	A 2-70	0244806	0244806	0244806
18	2	Spring washer	A 2	0948828	0948828	0948828
19	2	Cap screw	A 2-70	0075564	0075564	0075564
20	1	Grooved taper pin	A 2	0126003	0126003	0126003

13.3. Pneumatic three-position drive

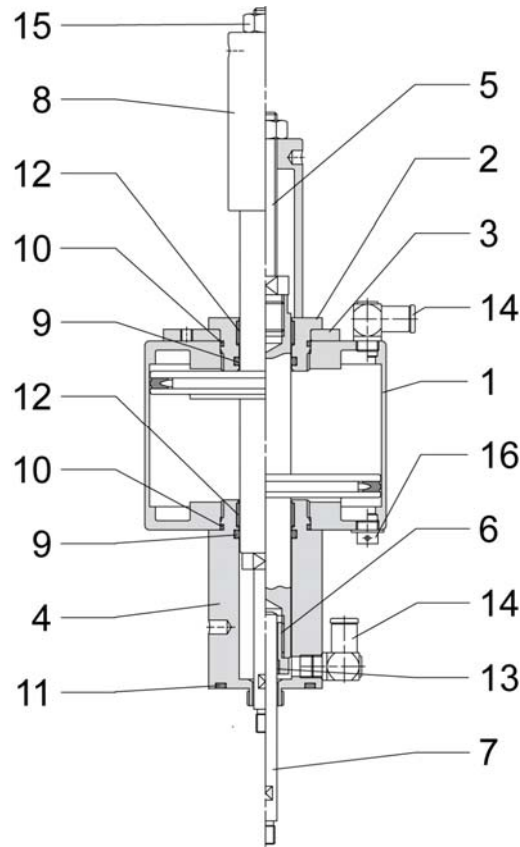

Pos.	Quantity	Designation	Material	Order No.
	1	Three-position drive		2143282
1	1	Cylinder		2128615
2	1	Locking screw	1.4301	2131739
3	1	Adapter disk	1.4301	2128219
4	1	Hub flange	1.4301	2143277
5	1	Adjusting screw	1.4301	2143281
6	1	Centering screw	1.4301	2143280
7	1	Spindle	1.4301	2143279
8	1	Stop	1.4301	2143278
9	2	O-ring	* NBR	0116723
10	2	O-ring	* NBR	2128764
11	1	O-ring	* NBR	0443473
12	2	Friction bearing	* Iglidur	2131740
13	1	Friction bearing	* Iglidur	2111971
14	1	Angular screw-in connection		2116513
15	1	Hexagon nut	A 2-70	0165217
16	1	Threaded plug	PP	2128550
	1	Sealing kit cpl. consisting of:	*	2309121

14. EC Declaration of Incorporation

The manufacturer,

Südmo Components GmbH
Industriestrasse 7
D-73469 Riesbürg-Pflaumloch

hereby declares that the:

Butterfly valves

Type: KV2007
Article Nos.: K580 – K588
K660 – K688
K660ISO – K688ISO
Year of manufacture: 2010

complies with the following basic requirements of the **Machinery Directive (2006/42/EC)**.
Annex I, Article 1.1.2, 1.1.3, 1.1.5, 1.3.2, 1.3.4, 1.5.3, 1.5.4, 1.5.5, 1.5.13, 1.6, 1.7.1, 1.7.2, 1.7.3, 1.7.4 and 2.1.

The partly completed machine / system component furthermore complies with all regulations of the directives **Electrical equipment (2006/95/EC)** and **Electromagnetic compatibility (2004/108/EC)**.

Applied harmonized standards

- ⇒ DIN EN 12100-1 Safety of machinery – Basic terms, general principles for design - Part 1: Basic terminology, methods
- ⇒ DIN EN 12100-2 Safety of machinery – Basic terms, general principles for design, part 2: Technical principles and specifications
- ⇒ DIN EN 60204-1 Safety of machinery - Electrical equipment of machines, Part 1: General requirements
- ⇒ DIN EN 1672-2 Food processing machinery – Basic concepts – Part 2: Hygiene requirements

Do not put the partly complete machine / system component into operation unless it has been verified that the machine/system the partly complete machine/system component is to be built into complies with the regulations of the machinery directive (2006/42/EC).

The manufacturer commits to send the special documents regarding the partly completed machine **as a hard copy** to the national authorities. The industrial property rights of the manufacturer of the partly completed machine shall not be affected thereby.

TD authorized person

Engineering management: Werner Deger,
Südmo Components GmbH
Industriestrasse 7, D-73469 Riesbürg, Germany

Riesbürg, 22.09.2010

Managing director
Oliver Rupp

15. Declaration of Conformity

According to annex VII of the Pressure Equipment Directive 97/23/EC

The manufacturer,

Südmo Components GmbH
Industriestrasse 7
D-73469 Riesbürg-Pflaumloch

hereby declares in sole responsibility that the product

Butterfly valves

Type: KV2007
Article Nos.: K580 – K588
K660 – K688
K660ISO – K688ISO

to which this declaration refers complies with the Pressure Equipment Directive 97/23/EC and has been submitted to the following conformity process:

Module A .

Applied harmonized European standards

- ⇒ DIN EN 10217-7 Welded steel tubes for pressure purposes-Technical delivery conditions - Part 7: Stainless steels tubes
- ⇒ DIN EN 10028-7 Flat products made of steel for pressure purposes - Part 7: Stainless steels
- ⇒ DIN EN 10222-5 Steel forged pieces for pressure purposes
- ⇒ DIN EN 10272 Rods made of stainless steel for pressure purposes
- ⇒ DIN EN 10088-1 Stainless steels – Part 1: List of stainless steels
- ⇒ DIN EN 10088-2 Stainless steels – Part 2: Technical delivery conditions for sheet/plate and strip made of corrosion-resistant steel for general purposes
- ⇒ DIN EN 10088-3 Stainless steels – Part 3: Technical delivery conditions for semi-finished products, bars, rolled wire, drawn wire, profiles and bright steel products made of corrosion-resistant steel for general purposes
- ⇒ DIN EN 287-1 Qualification test of welders
- ⇒ DIN EN ISO 15614-1 Specification and qualification of welding procedures for metallic materials – Welding procedure test – Part 1: Arc and gas welding of steels and arc welding of nickel and nickel alloys

Other applied standards and technical specifications

- ⇒ AD-2000 regulations
- ⇒ DIN EN 12266-1 Industrial fittings - Testing of metal fittings – Part 1: Pressure tests, test procedures and acceptance criteria - Mandatory requirements

Additions to the Declaration of Conformity

- ⇒ The nominal diameters DN 25 and smaller are defined according to the definition of the pressure equipment directive 97/23/EC“ according to Article 3 Paragraph 3 good engineering practice and **must not be marked** with the CE mark.
- ⇒ Valve manifolds:
The pressure test on the complete valve manifold cannot be carried out in the factory for manufacturing reasons. This test must be carried out when the entire system is commissioned at the customer's facilities. The individual valves have been tested by the manufacturer.



Please observe allowed range of application of the fitting
⇒ see chapter 3 "Field of application".

Riesbürg, 22.09.2010

Managing director
Oliver Rupp

16. Manufacturer's declaration for use in areas subject to explosion hazards

The manufacturer,

Südmo Components GmbH
Industriestrasse 7
D-73469 Riesbürg-Pflaumloch

hereby declares in sole responsibility that the product

Butterfly valves

Type: KV2007
Article Nos.: K580 – K588
K660 – K688
K660ISO – K688ISO

when used according to its designated use does not show any potential risk of ignition as defined by the EC directive 94/9/EC Article 1 and, thus, is not covered by the EC directive 94/9/EC.

Information regarding its designated use

- Underground use must be excluded.
- An equipotential bonding of the entire system must be ensured.
- The maximum surface temperature of the fitting depends on the temperature of the substance to be transported but due to friction pneumatically operated fittings will reach up to +80°C at an outside temperature of +40°C. This limits the ignition and glowing temperature of the substances that can be transported through the fitting.
- The fitting must not be used in Zone 0 for fluids of explosion group IIC (according to DIN EN 50014).
 - The surface area of non-conducting components is < 80 cm².
 - All non-conducting components are surrounded by a conducting frame.

Classification of the hazardous areas

- We point out that the classification in group, category, zone, protection class and temperature class and the definition of any special operating conditions have to be specified by the system manufacturer.
- Please note that leaks in a sealing element may result in the fluid escaping from the valve interior into the atmosphere.

Applied harmonized European directives and standards and other regulations

- ⇒ DIN EN 1127-1 Explosive atmospheres – Explosion prevention and protection – Part 1: Basic concepts and methodology
- ⇒ DIN EN 13463-1 Non-electrical equipment for use in potentially explosive atmospheres – Part 1: Basic method and requirements
- ⇒ DIN EN 50014 Explosion-proof electric motors

Other applied standards and technical specifications:

- ⇒ Directive 94/9/EC
- ⇒ BGR 132 Avoiding ignition hazards as a result of electrostatic charges

Components not included in the operating instructions are excluded from the manufacturer's declaration. Documentation must be ordered separately.



Please observe allowed range of application of the fitting
⇒ see chapter 3 "Field of application".

Riesbürg, 22.09.2010

Managing director
Oliver Rupp

17. Service address

Südmö Components GmbH

*Industriestraße 7
D-73469 Riesbürg - Germany*

T +49 9081 803-0

F +49 9081 803-158

E info@suedmo.de

I www.suedmo.de

© 2010 Südmö Components GmbH

Subject to technical modifications

Order No. 2308836