

Multi-spring actuator 813 20033 O B 0

Order-No.	./.
Comm.-No.	./.
Project	./.
Apparate-No.	Identification
./.	./.
ARCA Order-No.	./.
Item-No.	./.
Drawing-No.	204777

Key-No.: 81-32-3O-B00

1 Description of the function.....	3
2 Execution	3
3 Warning symbols.....	3
4 Safety Instructions.....	4
4.1 Qualified Personnel	4
5 Mounting site.....	5
6 Mounting.....	5
7 Adjustment.....	5
7.1 Stroke.....	5
7.2 Signal air connection.....	5
7.2.1 Standard.....	5
7.2.2 when using an ARCA positioner (integrated mounting)	5
8 Mounting the valve positioner.....	5
8.1 Integrated mounting of ARCA valve positioners.....	5
8.2 Mounting according to IEC 534 (NAMUR)	6
9 Modification / Exchange of spare parts	6
9.1 How to proceed	6
9.2 Reversing the action from „air to open“ to „air to close“	6
9.2.1 additional mounting steps.....	6
9.3 Guiding and sealing elements.....	6
9.4 Diaphragm.....	7
9.5 Springs.....	7
10 Sectional drawings	8
10.1 No.204777 (air to open)	8
10.2 No.204780 (air to close).....	9
11 Parts List	10
12 Table(s) of torque moments.....	11
12.1 Screw connections, general.....	11

1 Description of the function

The actuator series 813 is designed as a single-acting multi spring diaphragm actuator for armatures with a linear stroke. The central spindle (1) of the actuator is connected to the spindle of the armature by means of a coupling. The actuator spindle is precisely guided in a slide bearing (5), and the operating air chamber is sealed with a special gasket with wiper ring (3). Connected to the spindle (1) is a diaphragm plate (10), which supports the diaphragm (13) and transmits its movements to the spindle (1). The diaphragm (13) separates the actuator body (9, 15) into pressure chamber and spring chamber. The actuator spindle (1) is moved when the force of the operating air on one side of the diaphragm (13) surpasses the force of the springs (14) on the other side. The spring chamber is ventilated by means of a splashproof cap (17) to avoid positive or negative pressures in the spring chamber.

2 Execution

- compact design
- fabric-reinforced diaphragm
- flexible force control
- special splash-proof ventilation
- stainless steel actuator body
- robust stainless steel yoke according to NAMUR
- the action (air-to-open/air-to-close) can be reversed with additional parts.

3 Warning symbols

Safety informations and warnings are intended to avert danger from the life and health of users and maintenance personnel and to prevent material damage. They are highlighted in this manual by the headings defined here. They are also marked by warning symbols next to where they appear. The headings used have the following meaning for the purposes of this manual and the product labels.

Danger



indicates that death, severe personal injury or substantial property damage will result if proper precautions are not taken.

Warning



indicates that death, severe personal injury or substantial property damage will result if proper precautions are not taken.

Caution



indicates that minor personal injury or property damage can result if proper precautions are not taken.

Note



indicates an important information about the product itself or the respective part of the instruction manual which is essential to highlight.

4 Safety Instructions

Warning



Maintenance and repair of the actuator must only be carried out by qualified personnel.

The actuators produce high positioning forces. Mounting and starting up must be carried out under careful consideration of the safety instructions.

Special reference is made to strictly follow the rules and regulations for plants with explosion hazards.

Before starting any maintenance works it must be secured that no third person can put the plant into operation.

4.1 Qualified Personnel

Warning



in the sense of the operating instructions are persons who are familiar with the mounting, starting up, and operation of this product and who have the corresponding qualification for such works, e.g.

- Education or training according to the actual safety standards for maintenance and use of adequate safety equipment.
- First aid training
- For plants with explosion hazards: Special training or instructions, or the authorization respectively to carry out works in plants with explosive hazards.

5 Mounting site

- The actuator should be easily accessible, at least from one side and from above.
If mounted in an elevated position, a service gangway or similar should be provided.
- For actuators size MFIII and larger, an electric crane or a hoist should be provided.

6 Mounting

The yoke of the actuator (34) is provided with a single, centred mounting hole, which allows a rotation of the actuator in any direction. The mounting on the armature is carried with of the clamping rings of the armature. Actuator and armature are coupled with the stroke indicator.

Caution



Note:

Mounting position: pipe line horizontal;
actuator position vertikal;
diaphragm chamber above the armature

In case of other arrangements please consult us for further information.

- Arrange position of actuator and additional equipment in true alignment with the armature!

7 Adjustment

7.1 Stroke

Caution



Note



The mounting of the stroke indicator for coupling the actuator to the armature is carried out according to the instructions for the stroke indicator.

- When coupling the actuator to the armature, make sure that no traverse forces are transmitted to the spindle (1).
- Do not distort the spindle (1) radially!
- When adjusting the stroke make sure that the closing position of the armature is not blocked by the internal, non-adjustable, stroke limitation of the actuator.

7.2 Signal air connection

The connections (Z...) of the actuator are threaded $G^{1/8}_{10}$

7.2.1 Standard

- Close connection „Z₁“ at the yoke (34) by means of a screw plug.
- Connect supply air pipe to connection „Z₂“ at the yoke (34) by means of a pipe union.

7.2.2 when using an ARCA positioner (integrated mounting)

- Close connection „Z₂“ at the yoke (34) with plug screw (29).
- Connect positioner according to its operating instructions.

8 Mounting the valve positioner

8.1 Integrated mounting of ARCA valve positioners

Operating air connection and stroke-tapping are realised directly when the positioner is plug-mounted. Further mounting details will be found in the operating instructions of the corresponding instrument.

8.2 Mounting according to IEC 534 (NAMUR)

The yoke (34) of the actuator has been designed according to the standard IEC 534 Part 6 (NAMUR) which allows the mounting of additional instruments by means of the mounting thread M8. Additional parts are required for the stroke tapping according to NAMUR.

9 Modification / Exchange of spare parts

9.1 How to proceed

Follow instructions under section „Safety Instructions“

- Dismantling in the described order
- Cleaning of all components
- Remounting in the reverse order
 - using the new parts
- Lubricate O-rings with suitable O-ring grease
- The exchange of static gaskets and O-rings is not described.

9.2 Reversing the action from „air to open“ to „air to close“

- Dismantle positioner, if provided
- Remove screw plug (39) with ring gasket (38)
- Unscrew hex. nut (18)
- Remove protective spray-water cover (41)
- Remove protective spray-water cover (17)
- Unscrew complete sleeve (4)
- Take off the complete actuator head and turn it upside down
- When remounting, follow instructions under section **Stroke** on page 5!

9.2.1 additional mounting steps

- Install external air pipes (43)

9.3 Guiding and sealing elements

- Dismantle stroke indicator
- Dismantle positioner, if provided
- Dismantle stroke tapping angle for the positioner, if provided
- Unscrew complete sleeve (4)
- When remounting, follow instructions under section **Stroke** on page 5!
- Remounting in the reverse order, using the new parts

Caution



- The actuator spindle (1) must be free from edges before the complete bushing (4) is slide on. If required, remove edge with fine grinding paper.
- In case of damages in the range of the sealing element , the spindle must be exchanged!
- The spindle must not be machined in this area!

9.4 Diaphragm

Danger



The springs (14) are installed with high tension. If the following instructions are not strictly regarded, grievous injuries, resulting in death, as well as serious material damages cannot be excluded.

Danger



- Dismantle positioner, if provided
- **Remove 4 hex. nuts (23) and bolts (21) evenly spread over the circumference.**
- **Install long bolts (21) M8 x 80 in grade 8.8 and new hex. nuts (23) in grade 8.8.**
 - The long bolts (21) and nuts (23) in grade 8.8 are **not** part of our supply!
- Loosen hex. nuts (23) of the short bolts (21).
- **Loosen hex. nuts (23) of the newly mounted bolts (21) evenly, to release the tension off the springs (14).**

Note



- Take off upper cover (15) of actuator
- Remove pressure springs (14)
- Unscrew hex. nut (18)
- Pull reversing sleeve (8) with diaphragm plate (10) off the spindle (1).
- Remove diaphragm (13) and replace by a new diaphragm (13)
 - The texture side of the diaphragm must show to the diaphragm plate (10)

9.5 Springs

Caution



- Dismantling according to section **Diaphragm** on page 7 until pressure springs (14) are dismantled.
- Exchange tension springs (14) against new springs.
 - The springs should always be exchanged as a complete set!
 - Note carefully the arrangement of the springs (14)!

Number of springs	Mounting at position
2	1 + 4
3	1 + 3 + 5
4	2 + 3 + 5 + 6
6	1-6
9	1 + 3 + 5 + 1 - 6
12	2x 1-6

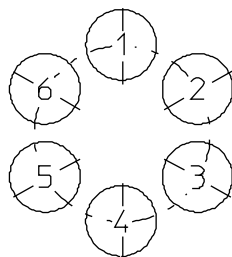

10 Sectional drawings

10.1 No.204777 (air to open)

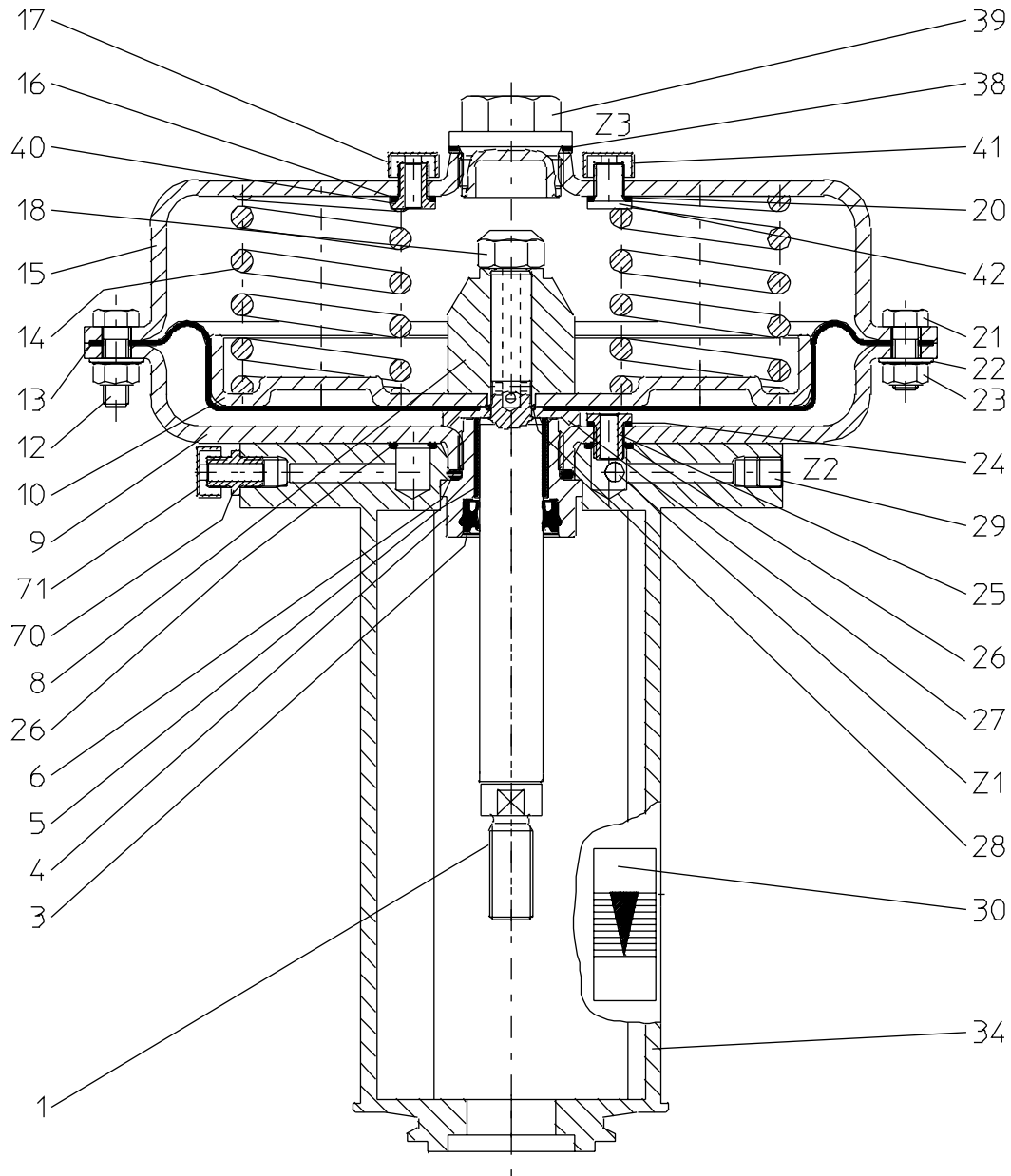

10.2 No.204780 (air to close)

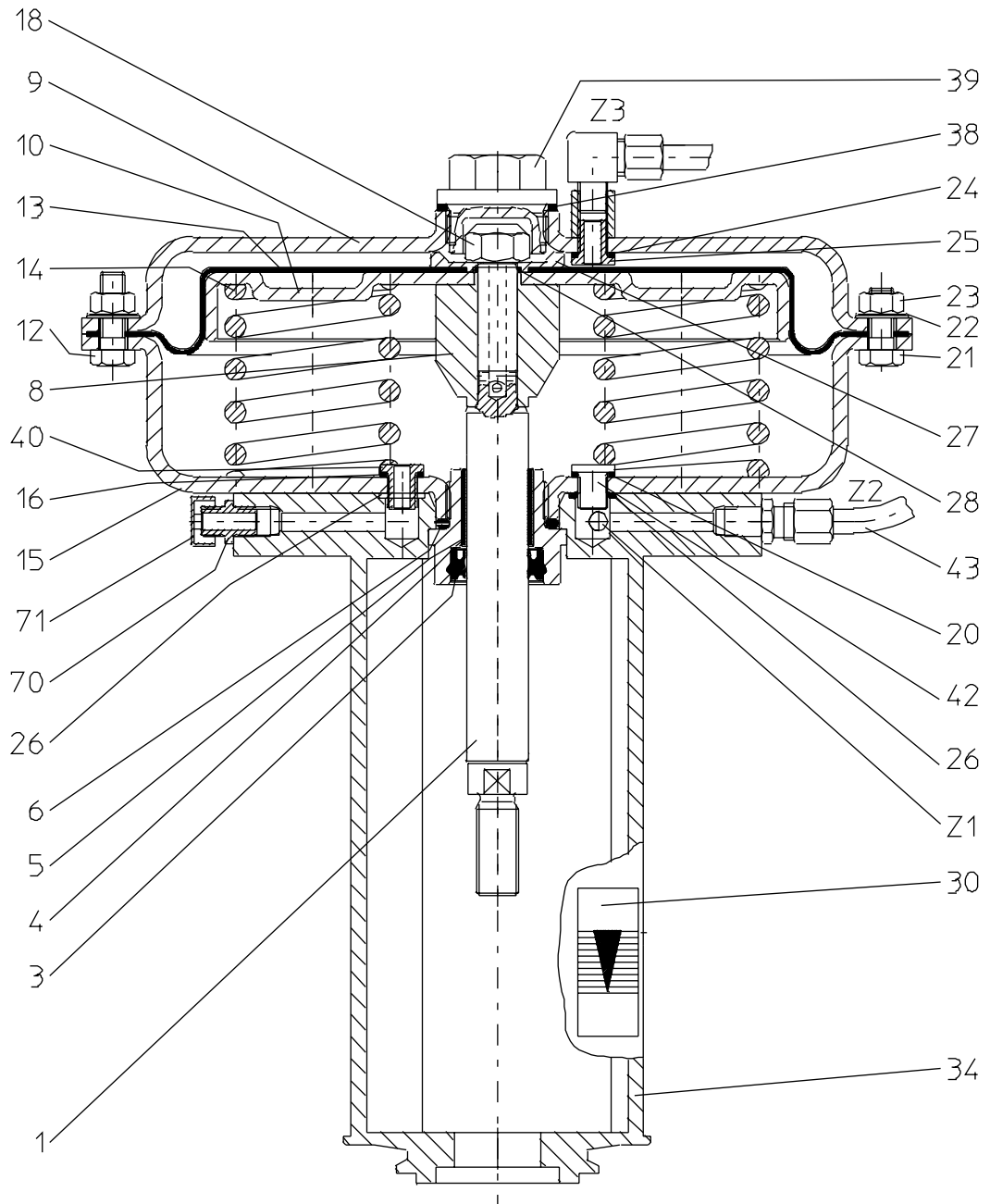

11 Parts List

Recommended spare parts are marked with an asterisk (*)
Spare parts list: see last page!

Item No.	Part Name
1	spindle
3	* gasket
4	bushing
5	* slide bearing
6	* O-ring
8	reversing sleeve
9	diaphragm cover
10	diaphragm plate
12	hex. screw
13	* diaphragm
14	* pressure spring
15	spring cover
16	gasket
17	* protective cap
18	* hex. nut
20	gasket
21	hex. screw
22	washer
23	hex. nut
24	gasket
25	threaded sleeve
26	* O-ring
27	cup
28	* O-ring
29	screw plug
30	stroke plate
34	yoke
38	* gasket
39	screw plug
40	threaded sleeve
41	protective cap
42	screw plug
43	* piping, complete
70	threaded nipple
71	protective cap

12 Table(s) of torque moments

12.1 Screw connections, general

Screws acc. to DIN933/931/939

Thread Size	Torque Moment [Nm]
M10	16
M12	30
M16	70
M20	100
M24	180
M27	330

Spare parts quotation / Order

To: ARCA-Regler GmbH
P.O. Box 2120
D-47913 Tönisvorst
Tel.:0 21 56 / 77 09-0
Fax.:0 21 56 / 77 09 55
eMail: sale@arca-valve.com

From:

We refer to the Apparate-number(s) _____

We would like to have your quotation for the following spare parts:

We herewith order the following spare parts:

Set of gaskets, consisting of parts Nos. 3, 5, 6, 17, 18, 26, 28, 38

Diaphragm part No. 13

Reversing set from „air-to-close“ into „air-to-open“, consisting of parts Nos. 43

Item No.	Part Name	quantity
3	gasket	
5	slide bearing	
6	O-ring	
13	diaphragm	
14	pressure spring	
17	protective cap	
18	hex. nut	
26	O-ring	
28	O-ring	
38	gasket	
43	pipng, complete	

Date / Signature

Key-No.: 81-32-30-B00