

BAA D610 Complete

Version 1.00

Double-seat valve type D610 Complete
DN 50 – 100, DN 2" – 4"
DN 40-ISO – DN 80-ISO

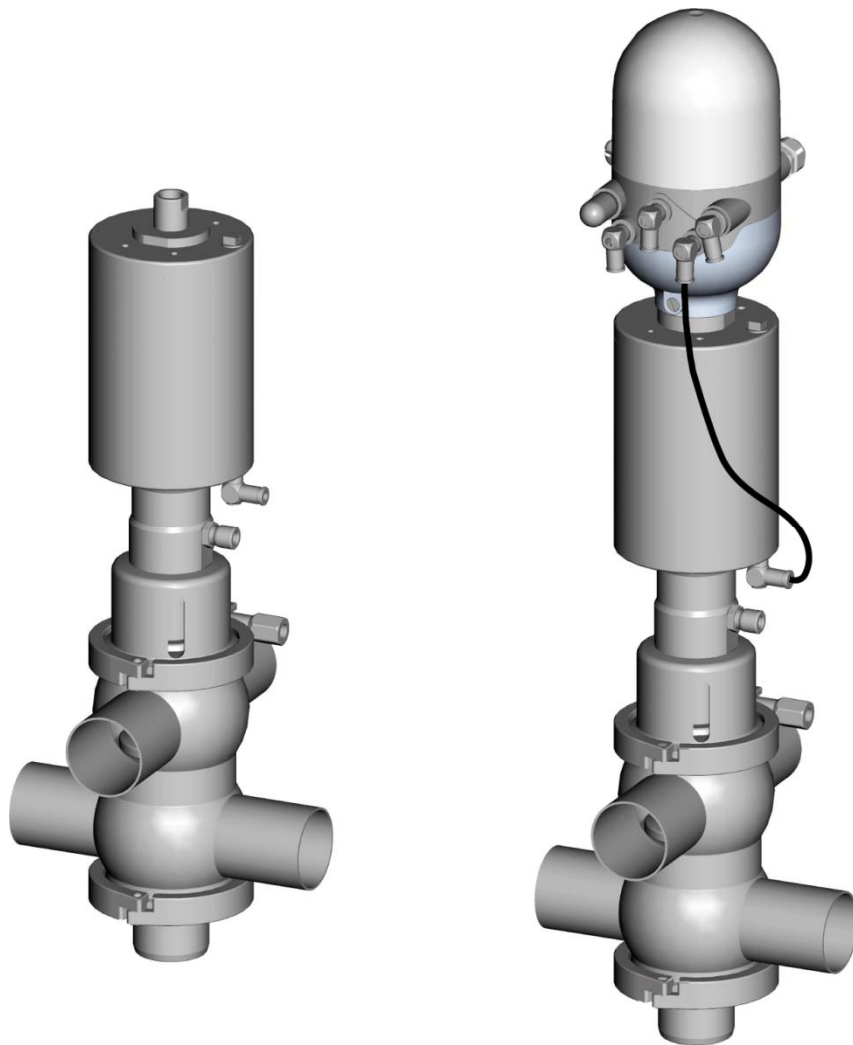

Revision	Date	Name	Revision	Date	Name	Revision	Date	Name	Revision	Date	Name

created on/by 08.11.2010 Graf H.
 reviewed on/by 08.11.2010 Feldmeier T. 1



en

1. Contents

1. Contents	2
2. Safety instructions	4
2.1. General	4
2.2. Maintenance and service work	4
2.3. Modifications of the double-seat valve	5
2.4. Double-seat valve with feedback	6
2.5. Cleaning, flushing, sterilization	6
2.6. Storage	6
2.7. Operation	6
2.8. Spare parts	6
2.9. Risk assessment	7
3. Field of application	7
3.1. Application field of the double-seat valves	7
3.2. Allowed operating media, pressures and temperatures	7
3.3. Place of use, environment	8
3.4. Media to be transported	8
3.5. Media to be transported in areas subject to explosion hazards	8
4. Technical Data	9
4.1. Dimensions	9
4.2. Valve use	10
4.3. Material data	10
4.3.1. Sealing materials	10
4.3.2. Stainless steels	10
4.4. CIP cleaning	10
4.5. Surfaces	11
4.6. Feedback systems	11
4.6.1. Simple or double feedback	11
4.6.2. Process control unit IntelliTop® 2.0	12
4.7. Electrical and pneumatic connections	12
4.7.1. Electrical connections	12
4.7.2. Pneumatic connections	12
4.7.3. Connection diagram - Process control unit IntelliTop® 2.0	13
4.8. Control air	13
4.8.1. Control air pressure	13
4.8.2. Control air quality	13
5. Valve function	14
5.1. Valve position "Closed"	14
5.2. Valve position "OPEN"	14
5.3. Rinsing of the leakage chamber	15
6. Valve connection piping	16
6.1. Installation position	16
6.2. Valve connections	16
6.3. Installation instructions for double-seat valves	16
7. Welding and mounting instructions	16
7.1. General remarks	16



7.2.	Delivery condition of the double-seat valve	16
7.3.	Installation instructions	17
7.3.1.	Installation space	17
7.3.2.	Installation	17
7.4.	Welding directives	17
7.5.	Weld seam preparation	17
7.6.	Welding	17
7.7.	Welding filler	17
7.8.	Weld seam finishing	17
7.8.1.	Interior	17
7.8.2.	Exterior	18
7.9.	Cleaning of the valve	18
7.10.	Valve mounting	18
8.	Dismounting – Mounting	18
8.1.	Preparatory measures for dismounting – mounting	18
8.2.	Spare parts	19
8.3.	Assembly tools	19
8.4.	Replacement of the seals	21
8.5.	Mounting of the O-rings	25
8.5.1.	Dismounting	25
8.5.2.	Installation	25
8.5.3.	O-ring mounting in the closing sleeve	25
8.6.	Subsequent installation of the process control unit IntelliTop [®] 2.0 onto the double-seat valve	26
9.	Commissioning of double-seat valve	27
9.1.	Functional test of the double-seat valve	27
9.2.	Leak test of the double-seat valve	27
10.	Maintenance	27
10.1.	Preparatory maintenance measures	27
10.2.	Inspection	28
10.3.	Preventive maintenance	28
11.	Malfunctions - Troubleshooting	29
12.	Disposal	29
13.	EC Declaration of Incorporation	30
14.	Declaration of Conformity	31
15.	Manufacturer's declaration for use in areas subject to explosion hazards	32
16.	Service address	34

2. Safety instructions



Danger

*This symbol denotes an **imminent danger** to life and health of persons!
Non-observance of these instructions leads to health risks or life-threatening injuries.*



Caution

*This symbol denotes a **potentially dangerous situation**!
Non-observance of these instructions can lead to light injuries or damage to material property.*



This symbol gives important information on the proper handling of the double-seat valve which must be strictly observed.

Non-observance of these instructions can result in malfunction of the valve or in its environment.

2.1. General

- ⇒ The double seat valves by Südmö Components GmbH have been manufactured in accordance with the state-of-the-art standards and recognized safety rules. However, these double-seat valves may constitute a hazard if used improperly by operating personal or for a purpose other than the designated one. This may result in a risk to life and limb of the user or of third parties, impair the function of the double-seat valve or cause damage to other material property.
- ⇒ Anyone who has been designated by the purchaser to assemble, start up, operate and maintain these double seat valves must have read and understood the complete operating instructions (especially all specified safety instructions).
- ⇒ In addition to these operating instructions, the following applies as a matter of course::
 - relevant accident prevention regulations
 - generally recognized safety rules
 - national regulations in the country of use
 - company-internal instructions concerning work and safety.

2.2. Maintenance and service work

- ⇒ Any maintenance and service work on the double-seat valves must be carried out by specially trained, qualified personnel only.
 - Training or instruction in accordance with the current safety standards.
 - For systems with explosion protection: training or instruction or authorization to carry out work on systems subject to explosion hazards (observe ATEX regulations).

Norit Südmö			
Order No./Auftragsnr.:	100152945	111123289	
ID-No./ID-Nr.:		2308418	
Ext. No./Erw. Nr.:			
Tag No./Taktnr.:			
Seal Kit No./ product side/produktseitig		2308531	
Dichtungs-Kit Nr.: actuator side/antriebsseitig		2308549	
Operating Pressure/Betriebsdruck:		10 bar	
Control Air Pressure/Steuerluftdruck:		6-8 bar	
⚠ Caution: Spring compression, dismantle carefully Achtung: Bei Demontage Federspannung beachten ⚠			
Month/Monat:	01 02 03 04 05 06 07 08 09 10 11 12	Final quality check	

Do NOT use
petroleum based lubricants!
KEINE
mineralölhaltigen Fette
verwenden!



Diagram A

- ⇒ Get information on possible risks that could be caused by residues of the operating material and take appropriate measures if necessary (safety gloves, safety goggles, etc.), before carrying out maintenance and service work on the double-seat valve.
- ⇒ Prior to carrying out any maintenance and service work, make sure that:
 - this work is only carried out in the depressurized state and with the media supply shut off.
 - the double-seat valve and all piping elements leading to the valve have been drained and cleaned or flushed.
 - the fittings have cooled down.
 - the system is not started by a third person.
 - the pressure build-up which may be formed in sealed pipelines is counteracted.
 - dismounting - mounting of the double-seat valve is carried out according to the mounting instructions (see chapter 8 "Dismounting - Mounting").
 - the power supply has been disconnected.
 - the double-seat valve is removed from the piping section, if possible.



Danger

Do not reach into valve openings or moving parts

⇒ **Risk of accidents.**

Risk of limbs being crushed or cut off.

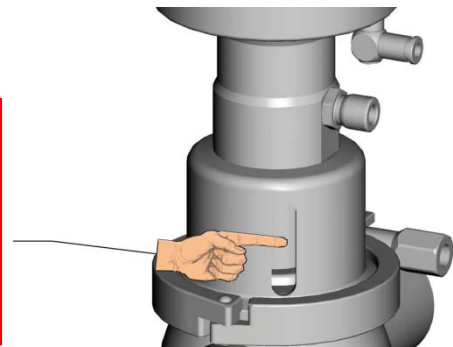

- ⇒ Avoid any working method impairing safety and function of the double seat valve.

2.3. Modifications of the double-seat valve

- ⇒ The outlet of the leakage chamber at the bottom side of the double seat valve must not be obstructed by mounting components or by other measures. The unhindered outlet of the leakages and of the cleaning, sterilization and rinsing agents to the atmosphere must be guaranteed.
- ⇒ If measures are taken to avoid or reduce the splashing of cleaning, sterilization and rinsing agents, they must be designed in a way that the free discharge of the agents to the atmosphere is not obstructed.
- ⇒ The assembly of additional components such as splash guards, hoses or pipes at the leakage outlets is only allowed after consultation with the valve manufacturer and after having received individual and detailed instructions by the manufacturer of the double seat valve.



Danger

⇒ *A strong reduction of the leakage discharge on the double-seat valve during the flushing of the double seat valve may lead - especially in combination with a high line pressure - to an unintentional opening of the double seat valve and the contents of the lower valve body may mix with the contents of the upper valve body.*

Due to the unintentional streaming in of pressurized liquids into the "wrong" chamber, dangerous situations may be generated, such as, for example, dangerous physical or chemical reactions or unintentional fluid discharges.

⇒ *Operate the double-seat valve according to the designated use and safety instructions.*

⇒ *Operate the double-seat valve in perfect technical condition only.*

⇒ *Modifications to the double-seat valve are strictly forbidden.*

2.4. Double-seat valve with feedback

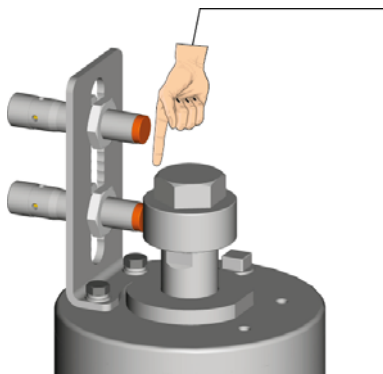

Do not reach into the feedback unit.
⇒ **Risk of accidents.**
Risk of limbs being crushed or cut off.

2.5. Cleaning, flushing, sterilization

- ⇒ The owner of the plant in which the double seat valve is built in must draw up operating instructions so that all the information required for the operation of the valve is available for the operating and maintenance personnel.
- ⇒ The start-up and operating personnel must wear protective clothing (gloves and safety goggles) during the cleaning, flushing and sterilization work.



During the automatic cleaning, rinsing and sterilization processes, hot media may escape at high speed periodically from the bottom part of the valve - among others vapor, base and acid solutions -
In order to avoid that the start-up and operating personnel come into contact with these media, which may cause serious injuries, the owner must provide additional measures and/or attach warning signs.

2.6. Storage

- ⇒ Store the valve in a dry place protected against external influences.
- ⇒ Prior to handling (dismounting of the body / activation of the actuators) temporarily store the valves in a dry place for at least 24 hours at a temperature $\geq 5^\circ \text{C}$.

2.7. Operation



- ⇒ **Never touch the valve or the pipelines if hot media are processed or if the sterilizing process is running.**
- ⇒ **Always adhere exactly to the operating parameters (see chapter 4 "Technical Data").**

2.8. Spare parts



- ⇒ **Use original spare parts only.**
- ⇒ **For original spare parts, refer to the enclosed spare parts list (see chapter 13 "Spare parts list").**
- ⇒ **Perfect functioning of the double-seat valve is only guaranteed when using original spare parts.**

2.9. Risk assessment

⇒ All safety instructions in these operating instructions result from the risk assessment for the double-seat valve.

3. Field of application

3.1. Application field of the double-seat valves

The Norit Südmo double-seat valves are used, among others, in

- ⇒ breweries
- ⇒ the beverage industry
- ⇒ the foodstuffs industry
- ⇒ the pharmaceutical industry
- ⇒ the chemical industry
- ⇒ the cosmetic industry

3.2. Allowed operating media, pressures and temperatures

Media	Allowed operating pressure	Minimum allowed operating temperature	Maximum allowed operating temperature
EPDM			
Products Water, beverages, pumpable food and cosmetics (liquids, emulsions, flowing suspensions)	< 10.0 bar overpressure	-5 °C or 1 K above freezing point	99 °C or at least 1 K below the evaporation temperature at atmospheric pressure
Aqueous cleaning base (based on sodium hydroxide, < 5 %*)	< 10.0 bar overpressure	-5 °C or 1 K above freezing point	99 °C or at least 1 K below the evaporation temperature at atmospheric pressure
Aqueous cleaning acid (based on nitric acid, < 3 %*)	< 10.0 bar overpressure	-5 °C or 1 K above freezing point	60 °C
Aqueous disinfectants (based on peracetic acid, < 0.7 %*)	< 10.0 bar overpressure	-5 °C or 1 K above freezing point	80 °C
Water vapor	< 2.7 bar abs or short-time (max. 20 min./day) < 4.7 bar abs	1 °C	short-time (max. 20 min./day) 150 °C
HNBR			
Products Water, beverages, pumpable food and cosmetics (liquids, emulsions, flowing suspensions)	< 10.0 bar overpressure	0 °C or 1 K above freezing point	99 °C or at least 1 K below the evaporation temperature at atmospheric pressure

Media	Allowed operating pressure	Minimum allowed operating temperature	Maximum allowed operating temperature
Aqueous cleaning base (based on sodium hydroxide, < 5 %*)	< 10.0 bar overpressure	0 °C or 1 K above freezing point	99 °C or at least 1 K below the evaporation temperature at atmospheric pressure
Aqueous cleaning acid (based on nitric acid, < 1.5 %*)	< 10.0 bar overpressure	0 °C or 1 K above freezing point	60 °C
Aqueous disinfectants (based on peracetic acid, < 0.2 %*)	< 10.0 bar overpressure	0 °C or 1 K above freezing point	30 °C
Water vapor	< 2.7 bar abs or short-time (max. 20 min./day) < 4.7 bar abs	1 °C	short-time (max. 20 min./day) 150 °C

* indications regarding the concentration refer to the dilution of the concentrate



If application-specific cleaning agents or other aggressive media are used, make sure they are suitable for the steel Cr-Ni (1.4404) and for the sealing material used and do not damage these materials. If in doubt please contact the valve manufacturer.



If the valve contains liquids, emulsions or suspensions above their respective evaporation temperature at atmospheric pressure, the switching of the valve or a leakage due to a wear of the seal may lead to a sudden escape of the complete contents of the pipe system in the form of vapor into the work area; this may result in a risk of injury to the persons staying in the work area.

3.3. Place of use, environment

- ⇒ The valve must only be used at places equipped with an acid- and base-resistant floor.
- ⇒ The places must be equipped with a normal illumination so that the labels and warning signs on the valve are clearly visible.
- ⇒ Permissible ambient temperature 0° C – 55° C.
- ⇒ Protect the valve rods against icing.

3.4. Media to be transported

Allowed state of aggregation	Liquids / Gases / Suspensions
Inadmissible media	radioactive, poisonous, very poisonous and environmentally hazardous media

3.5. Media to be transported in areas subject to explosion hazards

Allowed state of aggregation	Liquids / Gases / Suspensions
Inadmissible media	radioactive, poisonous, very poisonous and environmentally hazardous media



In addition, the restrictions according to the Manufacturer's Declaration for use in areas subject to explosion hazards must be observed. For more information on this, see also chapter 15. "Manufacturer's declaration for use in areas subject to explosion hazards"

4. Technical Data

4.1. Dimensions

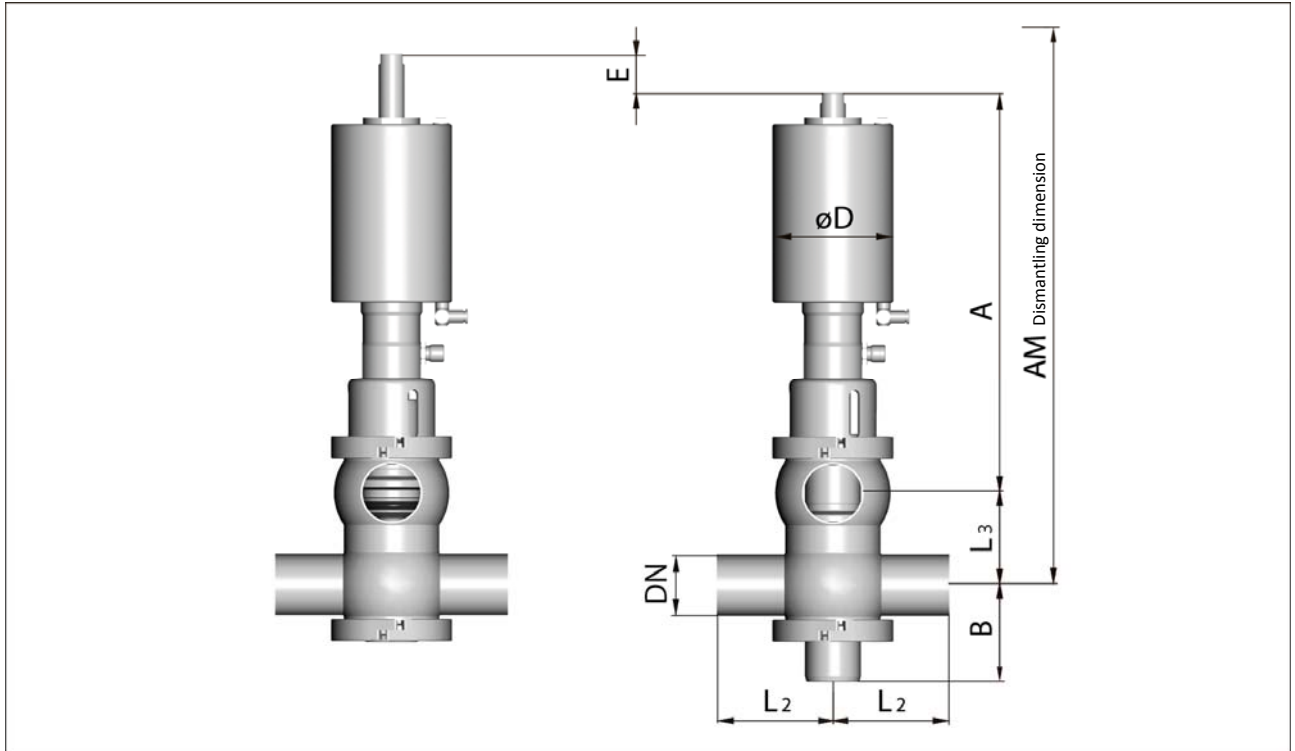

DN	Pipe ø	A	B	øD	E	L ₂	L ₃	AM	kg
Metric									
25									
40									
50	53 x 1.5	345	81	104	32	100	79	630	12
65	70 x 2	362	95	129	38	100	95	700	16.5
80	85 x 2	370	103	129	38	120	110	755	20
100	104 x 2	384	117	129	43	150	129	830	26
Inch									
1"									
1 ½"									
2"	50.8 x 1.65	346	80	104	32	100	79	635	12
2 ½"	63.5 x 1.65	365	92	129	38	100	95	705	16.5
3"	76.2 x 1.65	374	99	129	38	120	110	760	20
4"	101.6 x 2.11	385	116	129	43	150	129	830	26

Dimensions in mm

4.2. Valve use

Application: shut-off valve
 For use in: low-germ processes

Shut-off tightness:

Sealing material	Shut-off tightness
EPDM	max. 10 bar
HNBR	max. 10 bar

Vacuum: Leakage rate (residual pressure in the test item 0.5 mbar) = 1.6×10^{-6}

4.3. Material data

4.3.1. Sealing materials

⇒ EPDM

Temperature for continuous application in air: -5° C to +130° C

Resistant to

- Hot water up to 100° C
- Steam up to 130° C continuous load, short-term up to 150° C
- Wort up to 100° C
- Sodium hydroxide up to 100° C and a concentration of up to 5 %
- Nitric acid up to 60° C and a concentration of up to 3 %
- Peracetic acid up to 80° C and a concentration of up to 0.7 %
- Raspberry flavor at room temperature
- Cherry flavor at room temperature

⇒ HNBR

Temperature for continuous application in air: 0° C to +130° C

Resistant to

- Hot water up to 100° C
- Steam up to 130° C continuous load, short-term up to 150° C
- Sodium hydroxide up to 100° C and a concentration of up to 5 %
- Nitric acid up to 60° C and a concentration of up to 1.5 %



The service life of the seals depends on:

- ⇒ **Operating time per day**
- ⇒ **Switching intervals**
- ⇒ **Type of product, temperature, etc.**
- ⇒ **Type of cleaning (CIP / SIP)**

4.3.2. Stainless steels

In contact with product 1.4404 (AISI 316 L)
 Not in contact with product 1.4301 (AISI 304) / 1.4305 (AISI 304)

4.4. CIP cleaning



- ⇒ Inner chambers of the valve must be cleaned regularly.
- ⇒ When selecting the detergent, please observe the following:
 - Do not use abrasive detergents.
 - Use only detergents that are suitable for seals and stainless steel.
- ⇒ Do not exceed the concentrations and temperatures recommended by the detergent manufacturer.
- ⇒ Observe the safety data sheets issued by the detergent manufacturers!
- ⇒ Non-observance of these instructions will exempt the manufacturer from any warranty and liability.

Cleaning of the upper and lower valve body chamber is carried out by means of pipe cleaning. At the same time, the tube cleaning can be used to clean the leakage chamber by opening the closing sleeve or the valve disk.

Cleaning example for EPDM process valves in the food industry:

Cleaning step	Description	Duration	Flow velocity	Ventilation of the valve disk
Pre-rinsing	Process water at ambient temperature	5 – 10 min.	2 m/s	
Main cleaning process I (base step)	Base in aqueous solution 3% strength at 80°C	30 – 60 min.	2 m/s	3 x 5 sec.
Intermediate rinsing	Process water at ambient temperature	5 – 10 min.	2 m/s	2 x 5 sec.
Main cleaning process II (acid step)	Acid in aqueous solution 2% at 60°C	10 – 20 min.	2 m/s	3 x 5 sec.
Final rinsing	Water (drinking water quality) at ambient temperature	5 – 10 min.	2 m/s	2 x 5 sec.

Modifications of the double-seat valve

- ⇒ The outlet of the leakage chamber at the bottom side of the double seat valve must not be obstructed by mounting components or by other measures. The unhindered outlet of the leakages and of the cleaning, sterilization and rinsing agents to the atmosphere must be guaranteed.
- ⇒ If measures are taken to avoid or reduce the splashing of cleaning, sterilization and rinsing agents, they must be designed in a way that the free discharge of the agents to the atmosphere is not obstructed.
- ⇒ The assembly of hoses or pipes at the leakage outlet is only allowed after consultation with the valve manufacturer and after having received individual and detailed instructions from the manufacturer of the valve.



⇒ **A strong reduction of the leakage discharge on the double-seat valve during the flushing of the double seat valve may lead - especially in combination with a high line pressure - to an unintentional opening of the double seat valve and the contents of the lower valve body may mix with the contents of the upper valve body.**

⇒ **Due to the unintentional streaming in of pressurized liquids into the "wrong" chamber, dangerous situations may be generated, such as, for example, dangerous physical or chemical reactions or not intended fluid discharges.**

4.5. Surfaces

Surfaces in contact with the product	Standard Surface versions	$R_a \leq 0.8 \mu\text{m}$ - electropolished - higher-quality surfaces
Surfaces not in contact with the product	bright metal finish, $R_a \leq 1.6 \mu\text{m}$	

4.6. Feedback systems

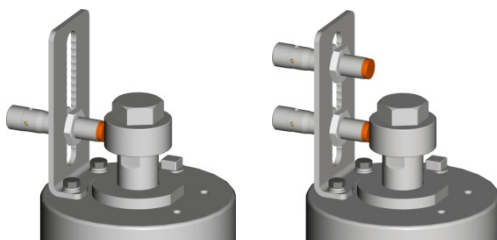

4.6.1. Simple or double feedback

- ⇒ Message: Valve position "Open" or/and "Closed"
- ⇒ Inductive feedback unit - Thread M 12 according to customer order
- ⇒ Feedback unit data - refer to data sheet of the feedback unit manufacturer
- ⇒ Add-on kit for feedback - Article no. 2132535

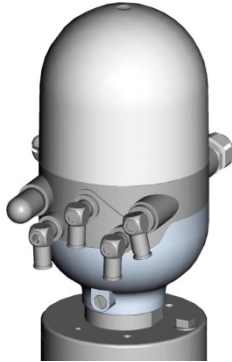

4.6.2. Process control unit IntelliTop® 2.0

Technical data	see Operating Manual IntelliTop 2.0
Pneumatic connections	see Operating Manual IntelliTop 2.0
Electrical connections	see Operating Manual IntelliTop 2.0
Maintenance	see Operating Manual IntelliTop 2.0

4.7. Electrical and pneumatic connections

4.7.1. Electrical connections

The electrical installation must be carried out, after the fitting has been installed in the system or pipeline.



Have the electrical installation carried out by skilled personnel.

- ⇒ Observe VDE-EVU and other locally applicable regulations.
- ⇒ Before connecting the unit, check whether the operating voltage and current intensity match specifications.

4.7.2. Pneumatic connections

- ⇒ Angular screw-in connection
 - ⇒ Standard G 1/8, air hose PE ø6/4
 - ⇒ USA G 1/8, air hose PE 1/4" (ø6.35)
- ⇒ Air hose specification - Recommendation
 - ⇒ Air hose, black hose 6/4 Order No. 0490227
hose 8/6 Order No. 0735563
 - ⇒ Material: Polyamide 12
Linear coefficient of expansion: 15×10^{-5}
Version according to DIN 73378 soft
 - ⇒ Max. operating pressure: AD 6/ ID 4 = 27 bar
AD 8/ ID 6 = 19 bar
all pressure indications at 20°C, higher temperatures have a negative effect on the max. operating pressure



- ⇒ **Use only calibrated hose pipes with an external diameter of 6 mm or 1/4" as well as 8 mm or 5/16" (tolerance +0.05/-0.1).**
- ⇒ **Cut the hose pipe only with a special hose cutter.**
- ⇒ **The length of the hose must be dimensioned in a way that prevents its buckling. Even single buckling of the hose damages it permanently.**
- ⇒ **Insert the air hose into the connector and fasten it. Avoid diagonal pull on connector.**

4.7.3. Connection diagram - Process control unit IntelliTop® 2.0

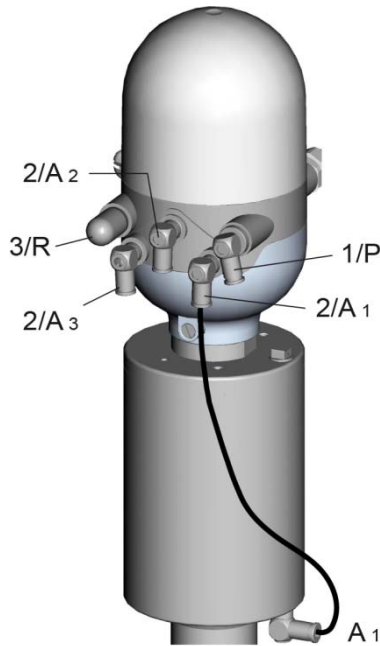

⇒ Main stroke
Connect air connection A₁ and control unit output 2/A₁ using an air hose.

4.8. Control air

4.8.1. Control air pressure

min. 6 bar – max. 8 bar

Process control unit IntelliTop® 2.0 refer to Operating Manual IntelliTop 2.0

4.8.2. Control air quality

according to DIN ISO 8573.1

Solids content

Particle size max. 5 µm
Particle density max. 5 mg/m³ (quality class 3)

Water content

Quality class 3
Dew point

-20° C
or min. 10° C below the lowest ambient temperature

Oil content

Quality class 3, preferably oil-free, max. 25 mg of oil in 1 m³ of air



Use only clean control air according to the specification!

5. Valve function

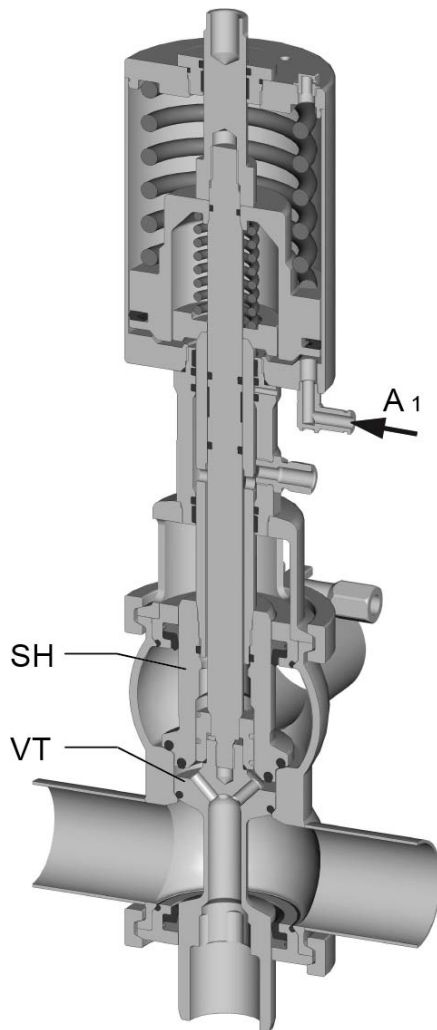

5.1. Valve position "Closed"

- ⇒ Control air pressure 0 bar on connection A₁.
- ⇒ Separation of two hostile media
- ⇒ Leakages, if any, are guided outwards through the leakage room in a depressurized state.

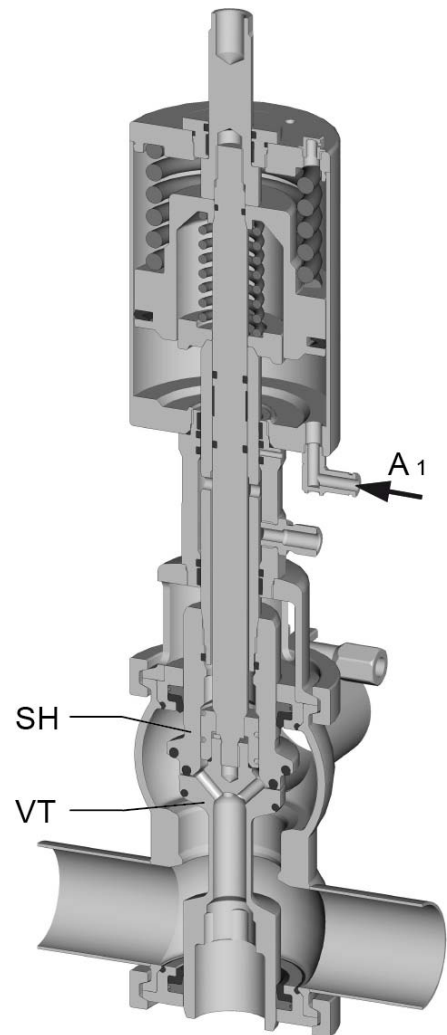

5.2. Valve position "OPEN"

- ⇒ Control air pressure 6 bar on connection A₁.
- ⇒ Valve disk VT is lifted and closes the leakage chamber
- ⇒ Valve disk VT and closing sleeve SH in "Open" position
- ⇒ Top and bottom rail will open in relation to each other.
- ⇒ Switching loss is guided outward via the leakage chamber during the switching operation "main stroke".

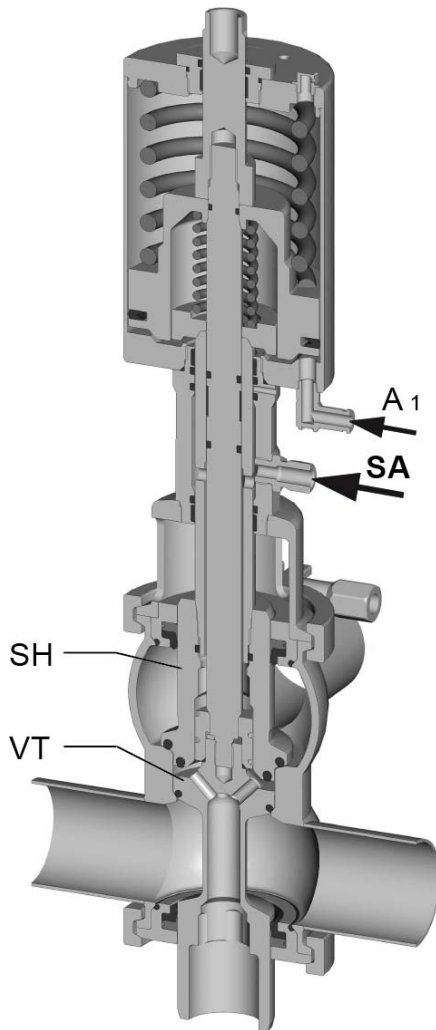

5.3. Rinsing of the leakage chamber

- ⇒ Control air pressure 0 bar on connection A₁.
- ⇒ Separation of two hostile media
- ⇒ Cleaning via SA connection



- **Cleaning pressure max. 10 bar**
- **Hose must be suitable for**
 - **cleaning pressure**
 - **cleaning temperature**
 - **cleaning medium!**

- ⇒ Leakages and the cleaning medium escape to the atmosphere through the leakage chamber.

6. Valve connection piping

6.1. Installation position

Vertical
Ensure that product can drain from the valve and piping.

6.2. Valve connections

Connections

- Welding end
- Threaded connection
- Clamp connection
- Small-flange connection

For welding instruction, please refer to chapter 7 "Welding and mounting instructions".

6.3. Installation instructions for double-seat valves

- ⇒ Dismount the double-seat valve as specified in the mounting instructions.
- ⇒ Weld or mount the double-seat valve into the pipe.



Caution

Welding information

- ⇒ *Dismount the seals before welding.*
- ⇒ *Weld housing free from tension and distortions.*
- ⇒ *Welding work must be carried out by qualified skilled personnel (DIN 287-1 W11) only.*

Mounting information

- ⇒ *When the valves are mounted, no foreign material must remain in the pipeline.*

- ⇒ For the mounting instructions, please refer to chapter 8 "Dismounting - Mounting".

7. Welding and mounting instructions

7.1. General remarks



Caution

Welding work must be carried out by qualified skilled personnel (DIN°287-1°W11) only.

Norit Südmö cannot be held liable for any damage resulting from incorrect installation.

7.2. Delivery condition of the double-seat valve

- ⇒ Factory-tested
- ⇒ Ready for installation or prepared for welding into the piping

7.3. Installation instructions

7.3.1. Installation space

Before starting mounting, determine and define the connection axes. For the installation dimensions, please refer to the dimensional drawings.

Ensure that there is sufficient space available for both operation and servicing.

7.3.2. Installation

Make sure that the fittings and piping are not subject to any tensile or compressive stresses.

7.4. Welding directives

Field of application Welding of fittings into pipes according to DIN 11850 series 1, 2; OD-Tube; DIN EN ISO 1127

Welding process TIG (tungsten inert gas welding)

Type of weld seam ⇒ Preparation of weld seam acc. to DIN 2559 (edge form I / for I-seams)
 ⇒ Weld seams correspond to DIN EN ISO 5817
 → evaluation group B (high)

7.5. Weld seam preparation

- ⇒ Saw off the pipe ends planar at a right angle and debur them (pipe saw M882).
- ⇒ Align the welding ends of the valve body and piping radially and axially, ensuring they are fitted flush together (centering device).



- ⇒ **Avoid too large a gap at the flush-fitting welding ends.**
- ⇒ **Make sure that enough forming gas arrives at the welding seam.**

7.6. Welding

- ⇒ Connect the forming gas.
- ⇒ Tack at 3 or 4 points.
- ⇒ Weld the valve → type of welding: TIG manual or orbital (automatic welding).

7.7. Welding filler

Material allocation

Material of parts to be welded	Suitable welding filler		
	1.4430	1.4440	1.4519
1.4404	X		
1.4435	X	X	X
1.4571	X	X	

7.8. Weld seam finishing

7.8.1. Interior

Depending on the requirement, for example

- ⇒ untreated.
- ⇒ abrasive surface finishing (at accessible points).

7.8.2. Exterior

Weld finishing methods

- ⇒ Pickling - Ensure proper disposal of pickling paste
- ⇒ Brushing
- ⇒ Grinding
- ⇒ Polishing

7.9. Cleaning of the valve

Clean thoroughly before mounting.

7.10. Valve mounting

Perform mounting according to the mounting instructions (see chapter 8 "Dismounting - Mounting").

8. Dismounting - Mounting

Mount the double-seat valve in general after having read the safety instructions (see chapter 8.1. "Preparatory measures for dismounting - mounting").

8.1. Preparatory measures for dismounting - mounting

Before disconnecting the valve connections and the flange connection of the valve bodies, carry out the following steps:



- ⇒ **Mounting of the double-seat valves must be carried out by specially trained, qualified personnel only.**
 - **Training or instruction in accordance with the current safety standards.**
 - **For systems with explosion protection: training or instruction or authorization to carry out work on systems subject to explosion hazards (observe ATEX regulations).**
- ⇒ **Get information on possible risks that could be caused by residues of the operating material and take appropriate measures if necessary (safety gloves, safety goggles, etc.), before carrying out maintenance and service work on the double-seat valve.**
- ⇒ **Before disconnecting the valve connections and the flange connection of the valve bodies, make sure that**
 - **this work is only carried out in the depressurized state and with the media supply shut off.**
 - **the double-seat valve and all piping elements leading to the valve have been drained and cleaned or flushed.**
 - **the fittings have cooled down.**
 - **the system is not started by a third person.**
 - **the pressure build-up which may be formed in sealed pipelines is counteracted.**
 - **dismounting - mounting of the double-seat valve is carried out according to the mounting instructions.**



- when dismantling the control unit, the closing spring are preloaded with auxiliary assembly air. To actuate the valves in the manual mode, the supply voltage and/or electrical signal must be applied.
- when dismantling the control unit, the closing spring are preloaded. In case of non-observance the closing spring is not preloaded during the dismantling of the control unit of spring-closed valves, there is a risk of injury when removing the clamp connection.
- double-seat valves are secured against signaling, voltage and signal cut-off, operation or actuation.
- the power supply has been disconnected.
- the double-seat valve is removed from the piping section, if possible.

Note

- ⇒ Cordon off mounting area.
- ⇒ Make sure that the mounting area remains cordoned off while work is being performed.





8.2. Spare parts









Use original spare parts only.

- ⇒ For original spare parts, refer to the enclosed spare parts list (see chapter 13 "Spare parts list").
- ⇒ Perfect functioning of the double-seat valve is only guaranteed when using original spare parts.

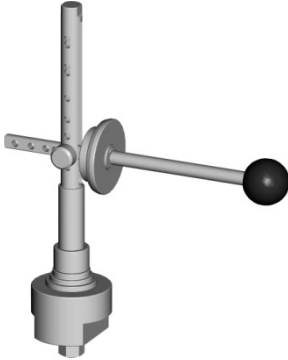
8.3. Assembly tools

Quantity	Tool	for	Order no.
1	Double wrench (wrench size) 17 - 19 	DN 25 – DN 100 DN 1" – DN 4"	2112372
1	Open-end wrench (wrench size) 46 mm 	DN 25 – DN 100 DN 1" – DN 4"	2123662
1	Open-end wrench (wrench size) 50 mm 	DN 25 – DN 100 DN 1" – DN 4"	2132643
1	Punch 155 mm 	DN 25 – DN 100 DN 1" – DN 4"	0098525
1	Hammer 300 g 	DN 25 – DN 100 DN 1" – DN 4"	2117644

Quantity	Tool	for	Order no.
2	Mounting shaft 	DN 25 – DN 100 DN 1" – DN 4"	2144190
1	Drift punch ø6 	DN 25 – DN 100 DN 1" – DN 4"	2123663
1	Socket key 	DN 25 – DN 50 DN 1" – DN 2" DN 65 – DN 100 DN 2 1/2" – DN 4"	2160290 2144338
1	Mounting device 	DN 25 – DN 100 DN 1" – DN 4"	2149869
1	Screwdriver 5.5 mm (slot) 	DN 25 – DN 100 DN 1" – DN 4"	2117639
1	Screwdriver 3.0 mm (slot) 	DN 25 – DN 100 DN 1" – DN 4"	2112374
2	Brush (small) S400, size 2 	DN 25 – DN 100 DN 1" – DN 4"	0050799
1	Hexagon head screwdriver 4.0 mm 	DN 25 – DN 100 DN 1" – DN 4"	2127638

8.4. Replacement of the seals



Caution

Avoid any damage to the metallic surfaces of the valve disks and to the valve disk gasket.

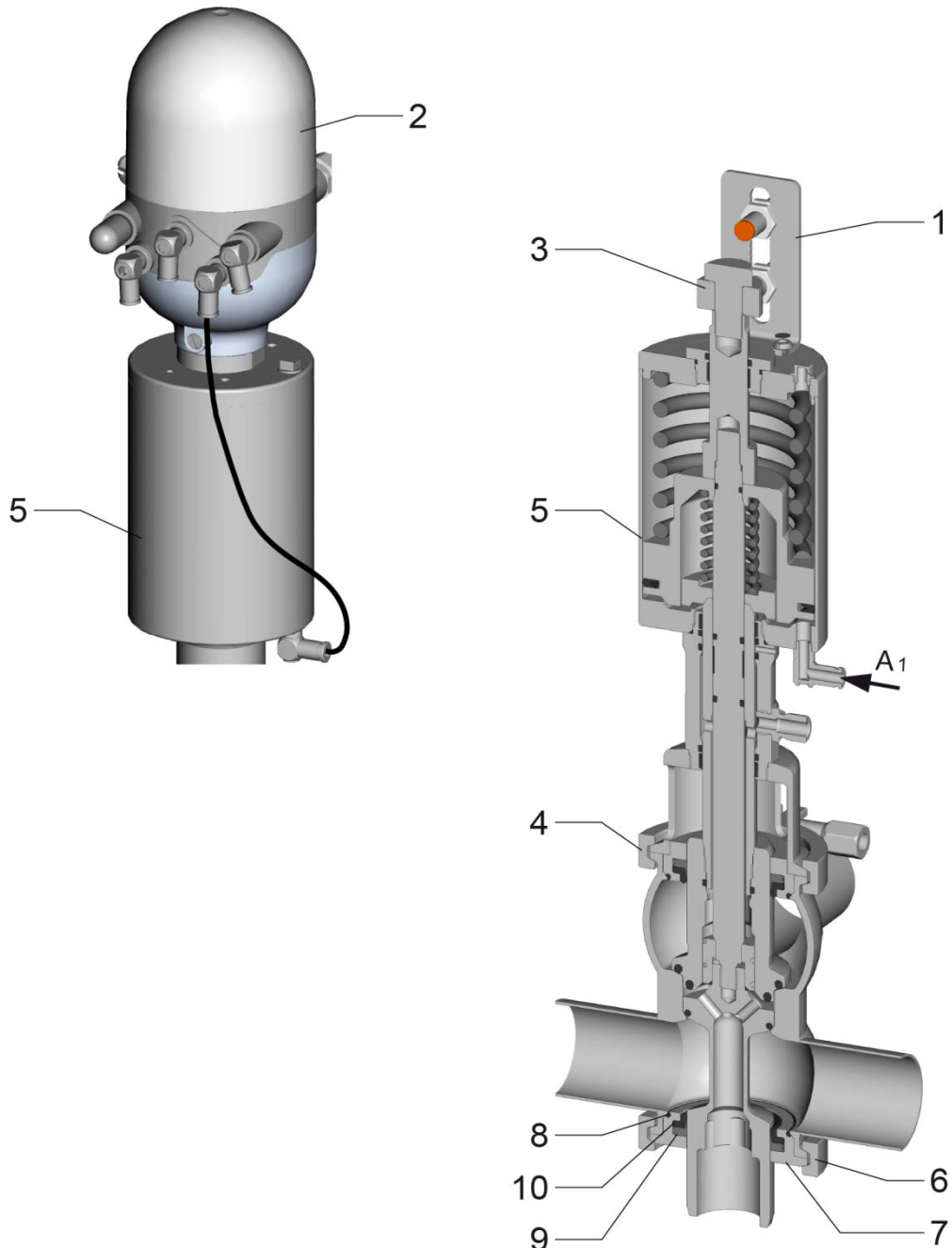

Valve dismounting

- I.1. Disconnect the electrical and pneumatic leads.
- I.2. Dismount the entire feedback (1) and/or process control unit (2) - see BA IntelliTop 2.0.
- I.3. Remove contact button (3).

- I.4. Mount the pneumatic supply line (auxiliary assembly air).
- I.5. Preload the actuator spring ⇒ Control air pressure min. 5 bar (auxiliary assembly air) to connection A1.
- I.6. Dismount clamp (4).



- ⇒ **Before disconnecting the valve connections and the flange connection of the valve bodies, make sure that the closing spring is preloaded before dismantling the control head. In case of non-observance there is a risk of injury when removing the clamp connection, due to the release of the spring tension of the actuator.**
- ⇒ **Do not reach into the openings of the closing head support (26) → Risk of accidents
Risk of limbs being crushed or cut off.**

- I.7. Release the actuator spring ⇒ Control air pressure 0 bar (auxiliary assembly air) on connection A1.
- I.8. Disconnect the pneumatic supply line (auxiliary assembly air).
- I.9. Remove upper part of valve (5).
- I.10. Loosen the clamp (6) and remove the valve cover (7).
- I.11. Remove O-ring (8), profile seal (10) and spacer ring (9) from the valve cover (8).

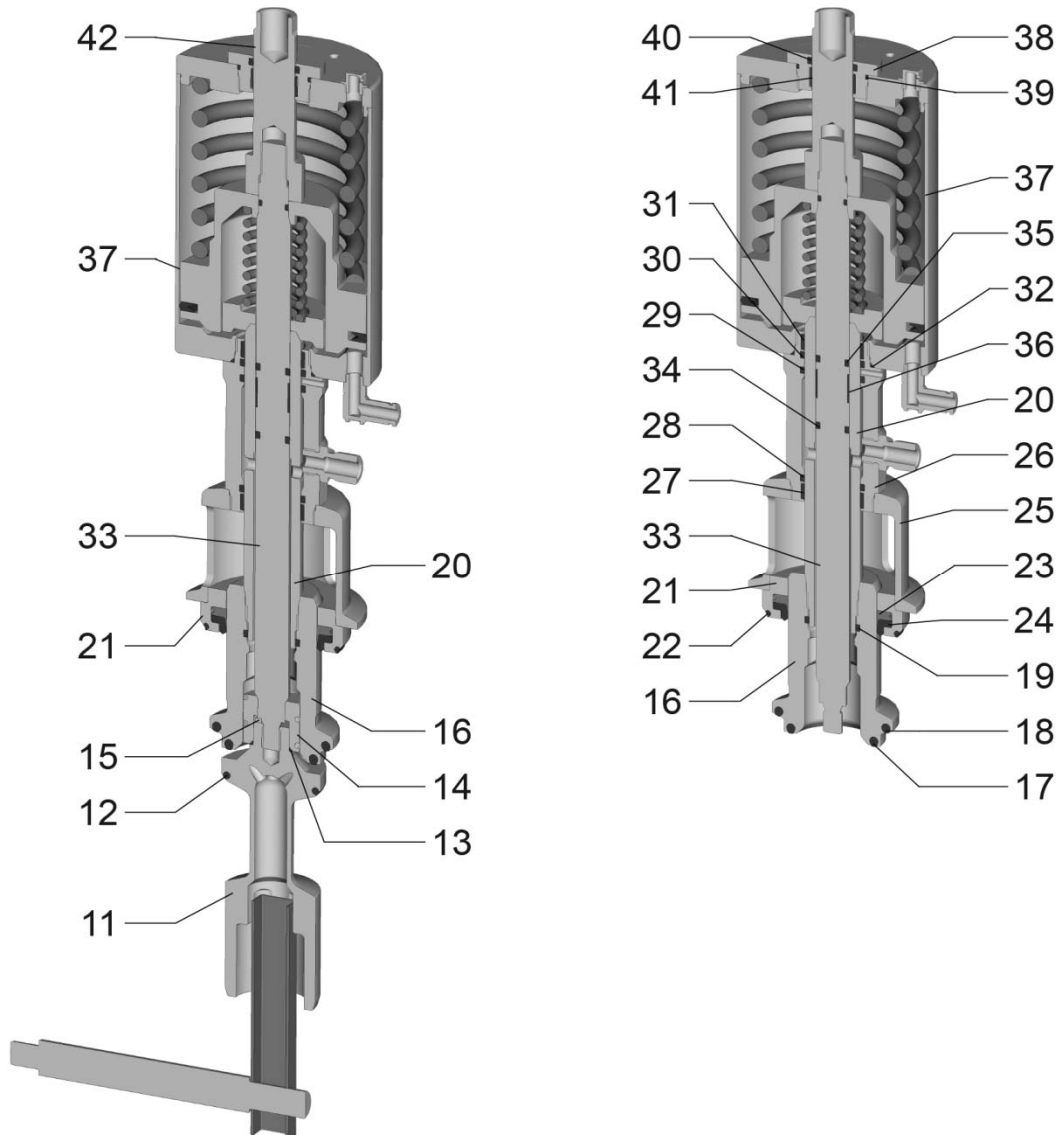

- I.12. Dismount the valve disk (11) by means of a socket key, mounting shaft and double wrench (wrench size) 17 - 19 for retaining at the piston rod (42) and remove the O-rings (12, 13) - see chapter 8.5 "Mounting the O-rings".
- I.13. Dismount the valve disk guide (14) and remove spring washer (15).
- I.14. Remove closing sleeve (16) with intermediate piece (20) and support (21).
- I.15. Remove support (21) from the closing sleeve (16) and remove O-ring (22), profile seal (24) and spacer ring (23).
- I.16. Clamp socket key into vise.
- I.17. Insert closing sleeve (16) into socket key and unscrew intermediate piece (20) by means of drift punch $\varnothing 6$.
- I.18. Remove closing sleeve (16) from socket key.
- I.19. Remove O-rings (17, 18, 19) - see chapter 8.5. "Mounting the O-rings".
- I.20. Clamp actuator cylinder (37) into vise - use soft clamping jaws.
- I.21. Dismount closing head support (25).
- I.22. Dismount flushing chamber (26) by means of open-end wrench (wrench size 50) and remove O-rings (28, 29, 30, 32) and guide bands (27, 31).
- I.23. Remove O-rings (34, 35) and friction bearing (36) from spindle (33).
- I.24. Remove actuator cylinder (37) from vise.
- I.25. Unscrew the locking screw (38) and remove O-rings (39, 40) and friction bearing (41).

Valve mounting

- I.26. Prior to mounting, clean and grease the shafts and sliding surfaces.

Sealing materials	Grease type
EPDM	PARALIQ GTE 703
HNBR	PARALIQ GTE 703
Thread	IFB PW 119 Apply a thin layer at the perimeter by means of a brush



- ⇒ **If a different grease is used,**
→ **corrosion of the sealing elements.**
- ⇒ **Do not use mineral greases and animal fat.**
- ⇒ **Do not use petroleum grease.**

- I.27. Install the O-rings (39, 40) and the friction bearings (41) in the locking screw (38).
- I.28. Mount the locking screw (38) on the actuator cylinder (37).
- I.29. Clamp actuator cylinder (37) into vise - use soft clamping jaws.
- I.30. Mount O-rings (34, 35) and friction bearing (36) in spindle (33).
- I.31. Mount O-rings (28, 29, 30, 32) and guide bands (27, 31) in flushing chamber (26).
- I.32. Mount flushing chamber (26) by means of open-end wrench (wrench size 50) in actuator cylinder (37).
- I.33. Screw the closing head support (25) onto the flushing chamber (26).
- I.34. Remove actuator cylinder (37) from vise.



- I.35. Mount O-ring (8) and profile seal (10) in valve cover (7).
I.36. Install spacer ring (9) in the valve cover (7).

	⇒	Ensure correct installation position of the spacer ring (9).
	⇒	Insert the end A of the spacer ring (9) into the gap between the profile seal (10) and valve cover (7).
	⇒	Insert the spacer ring (9) stepwise into the gap between the profile seal (10) and valve cover (7).

- I.37. Install O-ring (22) and profile seal (24) into the support (21).
I.38. Install spacer ring (23) in the support (21).

	⇒	Ensure correct installation position of the spacer ring (23).
	⇒	Insert the end A of the spacer ring (23) into the gap between profile seal (24) and support (21).
	⇒	Insert the spacer ring (23) stepwise into the gap between profile seal (24) and support (21).

- I.39. Mount O-rings (17, 18, 19) on the closing sleeve (16) - see chapter 8.5. "Mounting the O-rings".
I.40. Clamp socket key into vise.
I.41. Insert closing sleeve (16) into socket key.
I.42. Mount intermediate piece (20) by means of drift punch ø6 on closing sleeve (16).
I.43. Remove complete closing sleeve (16) from socket key.
I.44. Mount the entire support (21) onto closing sleeve (16).
I.45. Mount closing sleeve (16) with intermediate piece (20) and support (21) in flushing chamber (26).
I.46. Slide support (21) into the closing head support (25).
I.47. Mount O-rings (12, 13) on the valve disk (11) - see chapter 8.5. "Mounting the O-rings".
I.48. Mount the valve disk guide (14) on the spindle (33) of the actuator (37).
I.49. Mount the spring washer (15) on the spindle (33) of the actuator (37).
I.50. Mount the valve disk (11) by means of a socket key, mounting shaft and double wrench (wrench size 17 - 19) for retaining at the piston rod (42) on the spindle (33) of the actuator (37).
I.51. Install valve cover (7) with clamp (6) in the valve body.
I.52. Insert the upper part of the valve (5) axially into the valve body.

 Caution	⇒	<i>When installing the upper part of the valve avoid damaging the metallic seats/support or seals.</i>
---	---	---

- I.53. Mount the pneumatic supply line (auxiliary assembly air).
I.54. Preload the actuator spring ⇒ Control air pressure min. 5 bar (auxiliary assembly air) to connection A1.

 Danger	⇒	<i>Do not reach into the openings of the closing head support (26) → Risk of accidents.</i>
		<i>Risk of limbs being crushed or cut off.</i>

- I.55. Install the clamp (4).
I.56. Release the actuator spring ⇒ Control air pressure 0 bar (auxiliary assembly air) on connection A1.
I.57. Disconnect the pneumatic supply line (auxiliary assembly air).
I.58. Install contact button (3).
I.59. Mount the entire feedback (1) and/or process control unit (2) - see BA IntelliTop 2.0.
I.60. Connect pneumatic and electrical supply lines.

8.5. Mounting of the O-rings

8.5.1. Dismounting

- ⇒ The O-ring is installed in positive contact under pretension.
- ⇒ Remove the O-ring as shown in the drawing.

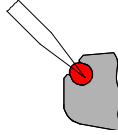

Caution

Do not damage the seal groove (edges of the groove).

8.5.2. Installation

- ⇒ Insert the O-ring in the sequence 1 - 2, 3 - 4, etc., into the groove.
- ⇒ Roll the O-ring section by section 1 – 6, 5 – 2 into the groove.
- ⇒ Use round object made of plastic or wood for the installation.



Caution

Avoid twisting and damaging the O-ring.

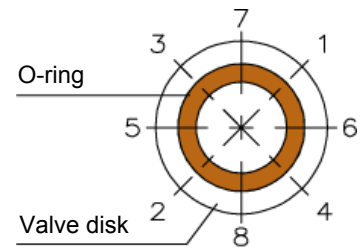

8.5.3. O-ring mounting in the closing sleeve

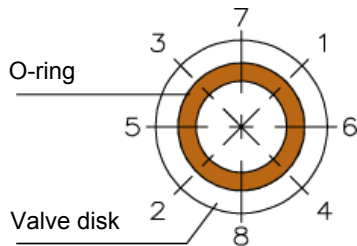
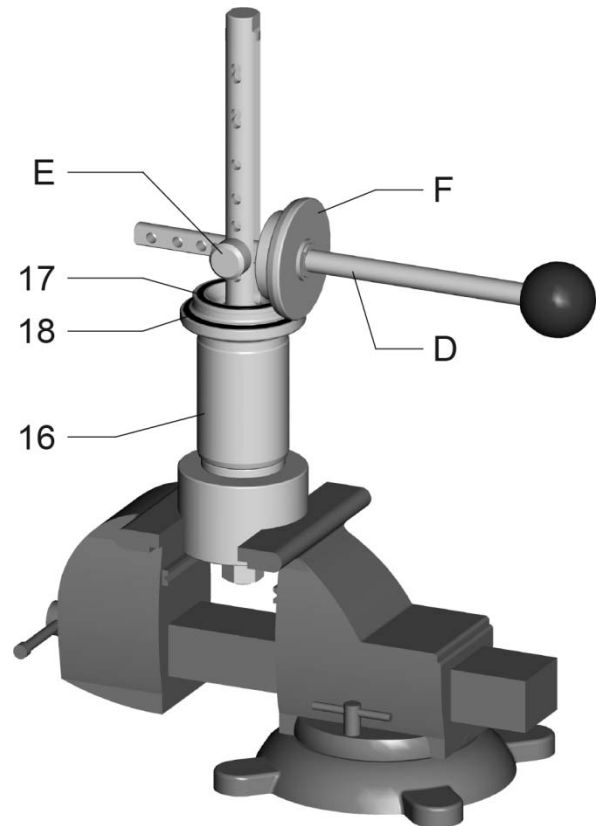
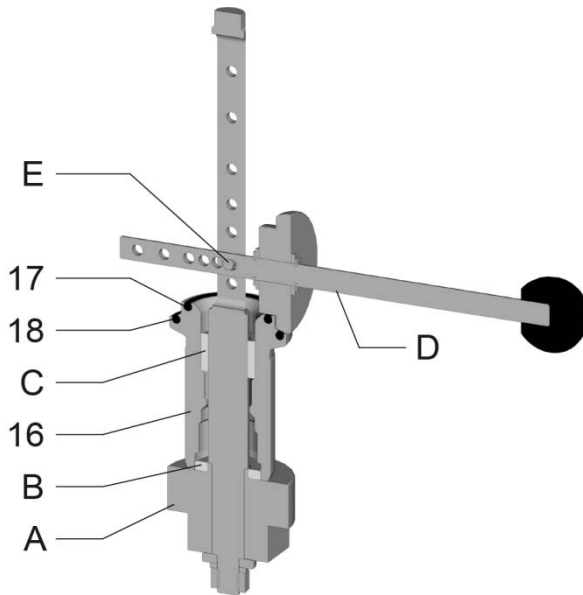

- ⇒ Clamp the mounting device (A) in the vise.
- ⇒ Place the sleeve (B) on the mounting device (A).
- ⇒ Position the closing sleeve (16) in the mounting device (A) and fix it by means of the guide ring (C).
- ⇒ Position the lever (D) with the locking pin (E).

- ⇒ Insert the O-rings (17, 18) in sequence 1 - 2, 3 - 4 etc. into the groove - For the installation use the lever (D) with the wheel (F).
- ⇒ Roll the O-rings (17, 18) section by section 1 - 6, 5 - 2 etc. into the groove - For the installation use the lever (D) with the wheel (F).
- ⇒ Roll the O-rings (17, 18) by means of the lever (D) **manually with even force application** (perform the rotary movement several times).



Check the positive seat of the O-rings after mounting.

8.6. Subsequent installation of the process control unit IntelliTop® 2.0 onto the double-seat valve

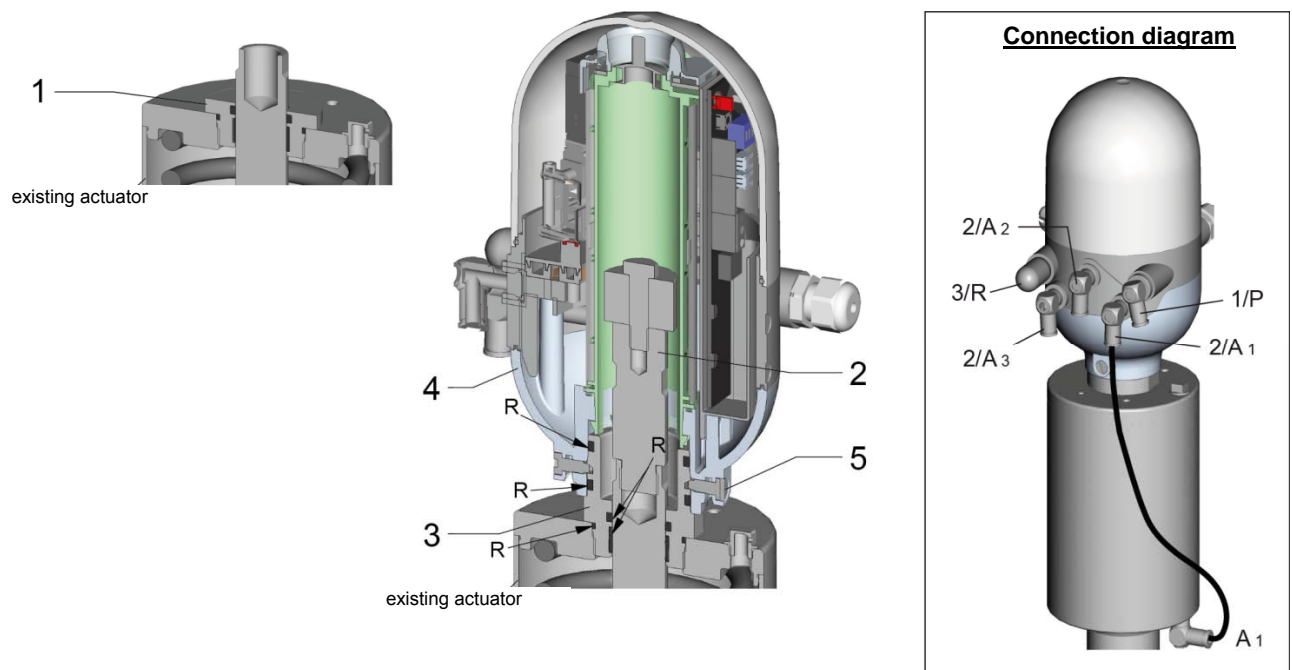

Dismounting of the control unit

- III.1. Unscrew the locking screw (1) - only required in case of a subsequent installation of the process control unit
- III.2. Dismount the pneumatic lines.
- III.3. Unscrew the cap screw (5).
- III.4. Remove the process control unit (4) from the adapter (3).
- III.5. Unscrew the contact button (2).
- III.6. Dismount adapter (3).

Mounting of the control unit

- III.7. Prior to mounting, clean and grease the shafts and sliding surfaces. Grease the sealing elements before installation.
- III.8. Mount adapter (3) on the double-seat valve. Prior to mounting, clean and grease the shafts and sliding surfaces. Grease the sealing elements before installation.

Lubrication plan

Apply R = RENOLIT SI 410 M - at the periphery using a brush

- III.9. Screw the contact button (2) on the piston rod of the double-seat valve.
- III.10. Place process control unit (4) on adapter (3).
- III.11. Mount the cap screw (5).
- III.12. Connect the pneumatic lines according to the connection diagram.

9. Commissioning of double-seat valve



Caution

- ⇒ *Ensure that no foreign objects are present in the piping system.*
- ⇒ *Avoid temperature shock!*
- Warm up the fitting slowly to the operating temperature.*

9.1. Functional test of the double-seat valve

Switch the valve several times by activating using compressed air.
Before start-up of the double-seat valve, the valve must be cleaned.

9.2. Leak test of the double-seat valve

Check visually if the seals have any leaks.
Replace defective seals.

10. Maintenance

10.1. Preparatory maintenance measures



Danger

- ⇒ *Mounting of the double-seat valves must be carried out by specially trained, qualified personnel only.*
 - *Training or instruction in accordance with the current safety standards.*
 - *For systems with explosion protection: training or instruction or authorization to carry out work on systems subject to explosion hazards (observe ATEX regulations).*
- ⇒ *Get information on possible risks that could be caused by residues of the operating material and take appropriate measures if necessary (safety gloves, safety goggles, etc.), before carrying out maintenance and service work on the double-seat valve.*
- ⇒ *Before disconnecting the valve connections and the flange connection of the valve bodies, make sure that*
 - *this work is only carried out in the depressurized state and with the media supply shut off.*
 - *the double-seat valve and all piping elements leading to the valve have been drained and cleaned or flushed.*
 - *the fittings have cooled down.*
 - *the system is not started by a third person.*
 - *the pressure build-up which may be formed in sealed pipelines is counteracted.*
 - *dismounting - mounting of the double-seat valve is carried out according to the mounting instructions (see chapter 8 "Dismounting - Mounting").*
 - *when dismantling the control unit, the closing spring are preloaded with auxiliary assembly air. To actuate the valves in the manual mode, the supply voltage and/or electrical signal must be applied.*



- *when dismantling the control unit, the closing spring are preloaded. In case of non-observance there is a risk of injury when removing the clamp connection, due to the release of the spring tension of the actuator.*
- *double-seat valves are secured against signaling, voltage and signal cut-off, operation or actuation.*
- *the power supply has been disconnected.*
- *the double-seat valve is removed from the piping section, if possible.*

Note

- ⇒ *Cordon off mounting area.*
- ⇒ *Make sure that the mounting area remains cordoned off while work is being performed.*

10.2. Inspection

Norit Südmo valves do not require special maintenance. In the intervals between maintenance procedures, however, it is necessary to check the tightness and correct operation of the seals by means of regular visual inspections.

10.3. Preventive maintenance

Practice-oriented maintenance intervals can only be determined by the respective user/operator as they depend on the following application parameters:

- ⇒ Operating time per day
- ⇒ Switching intervals
- ⇒ Type of product
- ⇒ Type of cleaning (CIP / SIP)

We can recommend the following data as reference values:

- ⇒ for liquids with solid particles and temperatures of 80° C to 100° C approx. every 3-6 months
- ⇒ for liquids with solid particles and temperatures of 60° C approx. every 12 months
- ⇒ for liquids without solid particles and temperatures of max. 60° C every 24 months.

11. Malfunctions - Troubleshooting



Caution

- ⇒ **In case of malfunctions, immediately shut off the valve and secure it against restart.**
- ⇒ **Malfunctions must be eliminated by qualified and trained personnel only while observing the safety instructions.**



Danger

- ⇒ **Never touch the valve or the pipelines if hot media are processed or if the sterilizing process is running.**
- ⇒ **Always adhere exactly to the operating parameters (see chapter 4 "Technical Data").**

Malfunction	Cause	Troubleshooting
Valve does not work	⇒ Fault in the control system	⇒ Check the system configuration
	⇒ No compressed air	⇒ Check compressed air supply
	⇒ Compressed air level is too low	⇒ Check if air hoses are free and tight
	⇒ Fault in the electrical system	⇒ Check activation / process control unit and electrical lines
Air escapes from the actuator	⇒ Pilot valve is defective	⇒ Replace the pilot valve
	⇒ Seals in the actuator are defective	⇒ Replace the seals ⇒ Replace the actuator
Valve does not close	⇒ Dirt / foreign objects in the seat area	⇒ Clean the valve body and the valve disk/closing sleeve sealing area
Valve closes too slowly	⇒ Seals in the actuator are dry (friction losses)	⇒ Grease the seals - See lubrication plan
Leakage from leakage chamber	⇒ Valve disk or closing sleeve seal defective	⇒ Replace the seals
Leakage on support	⇒ Seals are defective	⇒ Replace the seals
Leakage on the valve cover	⇒ Seals are defective	⇒ Replace the seals
Valve closes jerkily	⇒ Seals in the actuator are dry (friction losses)	⇒ Grease the seals - See lubrication plan ⇒ Replace the seals

12. Disposal

- ⇒ Dismount the double-seat valve according to the mounting instructions (see chapter 8 "Dismounting – Mounting").
- ⇒ Dispose of the double-seat valve in accordance with the local regulations of the country of destination.

13. EC Declaration of Incorporation

The manufacturer,

Südmo Components GmbH
Industriestrasse 7
D-73469 Riesbürg-Pflaumloch

hereby declares that the:

Double-seat valves

Type D610 Complete
Article no.: D611 Complete - D614 Complete
Year of manufacture: 2010

complies with the following basic requirements of the **Machinery Directive (2006/42/EC)**.
Annex I, Article 1.1.2, 1.1.3, 1.1.5, 1.3.2, 1.3.4, 1.5.3, 1.5.4, 1.5.5, 1.5.13, 1.6, 1.7.1, 1.7.2, 1.7.3, 1.7.4 and 2.1.

The partly completed machine / system component furthermore complies with all regulations of the directives **Electrical equipment (2006/95/EC)** and **Electromagnetic compatibility (2004/108/EC)**.

Applied harmonized standards

- ⇒ DIN EN 12100-1 Safety of machinery – Basic terms, general principles for design - Part 1: Basic terminology, methods
- ⇒ DIN EN 12100-2 Safety of machinery – Basic terms, general principles for design, Part 2: Technical principles and specifications
- ⇒ DIN EN 60204-1 Safety of machinery - Electrical equipment of machines - Part 1: General requirements
- ⇒ DIN EN 1672-2 Food processing machinery – Basic concepts – Part 2: Hygiene requirements

Do not put the partly complete machine / system component into operation unless it has been verified that the machine/system the partly complete machine/system component is to be built into complies with the regulations of the machinery directive (2006/42/EC).

TD authorized person

Engineering management: Werner Deger,
Südmo Components GmbH
Industriestrasse 7, D-73469 Riesbürg, Germany

Riesbürg, 08.11.2010

Managing director
Oliver Rupp

14. Declaration of Conformity

According to annex VII of the Pressure Equipment Directive 97/23/EC

The manufacturer,

Südmo Components GmbH
Industriestrasse 7
D-73469 Riesbürg-Pflaumloch

hereby declares in sole responsibility that the product

Double-seat valves

Type D610 Complete
Article no.: D611 Complete - D614 Complete

to which this declaration refers complies with the Pressure Equipment Directive 97/23/EC and has been submitted to the following conformity process:

Module A .

Applied harmonized European standards

- ⇒ DIN EN 10217-7 Welded steel tubes for pressure purposes-Technical delivery conditions - Part 7: Stainless steels tubes
- ⇒ DIN EN 10028-7 Flat products made of steel for pressure purposes - Part 7: Stainless steels
- ⇒ DIN EN 10222-5 Steel forged pieces for pressure purposes
- ⇒ DIN EN 10272 Rods made of stainless steel for pressure purposes
- ⇒ DIN EN 10088-1 Stainless steels – Part 1: List of stainless steels
- ⇒ DIN EN 10088-2 Stainless steels – Part 2: Technical delivery conditions for sheet/plate and strip made of corrosion-resistant steel for general purposes
- ⇒ DIN EN 10088-3 Stainless steels – Part 3: Technical delivery conditions for semi-finished products, bars, rolled wire, drawn wire, profiles and bright steel products made of corrosion-resistant steel for general purposes
- ⇒ DIN EN 287-1 Qualification test of welders
- ⇒ DIN EN ISO 15614-1 Specification and qualification of welding procedures for metallic materials – Welding procedure test – Part 1: Arc and gas welding of steels and arc welding of nickel and nickel alloys

Other applied standards and technical specifications

- ⇒ AD-2000 regulations
- ⇒ DIN EN 12266-1 Industrial fittings - Testing of metal fittings – Part 1: Pressure tests, test procedures and acceptance criteria - Mandatory requirements

Additions to the Declaration of Conformity

- ⇒ The nominal diameters DN 25 and smaller are defined according to the definition of the pressure equipment directive 97/23/EC according to Article 3 Paragraph 3 Good Engineering Practice and **must not be marked** with the CE mark.
- ⇒ Valve manifolds:
The pressure test on the complete valve manifold cannot be carried out in the factory for manufacturing reasons. This test must be carried out when the entire system is commissioned at the customer's facilities. The individual valves have been tested by the manufacturer.



Observe the permitted field of application of the fitting
⇒ see chapter 3 "Field of application".

Riesbürg, 08.11.2010

Managing director
Oliver Rupp

15. Manufacturer's declaration for use in areas subject to explosion hazards

The manufacturer,

Südmo Components GmbH
Industriestrasse 7
D-73469 Riesbürg-Pflaumloch

hereby declares in sole responsibility that the product

Double-seat valves

Type D610 Complete

Article no.: D611 Complete - D614 Complete

when used according to its designated use does not show any potential risk of ignition as defined by the EC directive 94/9/EC Article 1 and, thus, is not covered by the EC directive 94/9/EC.

Information regarding its designated use

- When dividing the system into zones, please note that each actuation (D601 - D604), each regular opening of the valve disk or of the closing sleeve or leak of an O-ring at the valve seat will discharge fluid from the valve interior into the atmosphere.
- Underground use must be excluded.
- An equipotential bonding of the entire system must be ensured.
- The maximum surface temperature of the fitting depends on the temperature of the substance to be transported but due to friction pneumatically operated fittings will reach up to +80°C at an outside temperature of +40°C. This limits the ignition and glowing temperature of the substances that can be transported through the fitting.
- The fitting must not be used in Zone 0. Moreover, the fitting must not be used in Zone 1 for fluids of explosion group IIC (according to DIN EN 50014).
 - The surface area of non-conducting components is < 200 cm².
 - All non-conducting components are surrounded by a conducting frame.

Classification of the hazardous area

- We would like to point out that the classification in group, category, zone, protection class and temperature class and the definition of any special operating conditions have to be specified by the system manufacturer.
- Note that leaks in a sealing element may result in the fluid escaping from the valve interior into the atmosphere.

Applied harmonized European directives and standards and other regulations

- ⇒ DIN EN 1127-1 Explosive atmospheres – Explosion prevention and protection – Part 1: Basic concepts and methodology
- ⇒ DIN EN 13463-1 Non-electrical equipment for use in potentially explosive atmospheres – Part 1: Basic method and requirements
- ⇒ DIN EN 50014 Explosion-proof electric motors

Other applied standards and technical specifications:

- ⇒ EC Directive 94/9/EC
- ⇒ BGR 132 Avoiding ignition hazards as a result of electrostatic charges

Components not included in the operating instructions are excluded from the manufacturer's declaration. Documentation must be ordered separately.



Observe the permitted field of application of the fitting
⇒ see chapter 3 "Field of application".

Riesbürg, 08.11.2010

Managing director
Oliver Rupp

16. Service address

Südmö Components GmbH

Industriestraße 7
D-73469 Riesbürg - Germany

T +49 9081 803-0

F +49 9081 803-158

E info@suedmo.de

I www.suedmo.de

© 2010 Südmö Components GmbH

Subject to technical modifications