

## BAA S385 Select

### SVP bottom seat valve

**DN 25 – 100, DN 1" – 4"**

Profile gasket – O-ring, Profile gasket – PEEK gasket

Manually and pneum. operated



Norit Südmo  
Bei Demontage  
Federspannung  
beachten  
Caution  
spring compression  
dismantle carefully

Änderung	Datum	Name	Änderung	Datum	Name	Änderung	Datum	Name	Änderung	Datum	Name
									BAA/0095	25.02.10	Lang

erst. am/von 25.02.2010 Lang  
gepr. am/von 25.02.2010



**Contents**

<b>Contents</b> .....	<b>2</b>
<b>Safety instructions</b> .....	<b>5</b>
General .....	5
Maintenance .....	5
Modification of the SVP bottom seat valve .....	6
SVP bottom seat valves with feedback .....	6
Storage .....	7
Operation .....	7
Spare parts .....	7
Risk assessment .....	7
<b>Technical data</b> .....	<b>8</b>
Dimensions .....	8
Valve use .....	11
Materials .....	11
Seal materials SVP bottom seat valve - profile gasket – O-ring .....	11
Seal materials SVP bottom seat valve - profile gasket – PEEK gasket .....	11
Stainless steel .....	12
CIP-Cleaning .....	12
Surfaces .....	12
Pneum. actuator .....	12
Function air opened – spring closed .....	12
SVP actuator with booster .....	13
Control systems .....	13
Single feedback .....	13
Double feedback .....	13
Process control head type 1066 .....	13
Process control head IntelliTop® type 8680 .....	13
Electrical and pneumatic connections .....	14
Electrical connections .....	14
Pneumatic connections .....	14
Air hose .....	14
Control air .....	15
Control air pressure .....	15
Control air .....	15
<b>Valve function</b> .....	<b>16</b>
SVP bottom seat valve with manual drive .....	16
SVP bottom seat valve with bevelled wheel drive .....	16
SVP bottom seat valve air opened – spring closed .....	17
<b>Valve connection piping</b> .....	<b>18</b>
Installation position .....	18
Valve connections .....	18
Installation instructions .....	18
Installation instructions weld-in flange .....	19

<b>Installation instructions</b> .....	<b>20</b>
General remarks .....	20
Delivery condition .....	20
Installation instructions .....	20
Installation space .....	20
Installation .....	20
Welding instructions .....	20
Area of application .....	20
Welding technique .....	20
Type of welding .....	20
Weld preparation .....	20
Welding .....	21
Weld filler materials .....	21
Weld finishing .....	21
Interior .....	21
Exterior .....	21
Cleaning .....	21
Assembly .....	21
<b>Dismantling – Assembly</b> .....	<b>22</b>
Before disassembly .....	22
SVP bottom seat valves with feedback .....	23
Spare parts .....	23
Mounting tools - Profile gasket – O-ring .....	23
SVP bottom seat valve, manually operated - Profile gasket – O-ring .....	24
SVP bottom seat valve with beveled wheel drive - Profile gasket – O-ring .....	26
Pneum. SVP bottom seat valve - Profile gasket – O-ring .....	28
Assembly instructions - Profile gasket – O-ring .....	30
Removal .....	30
Installation .....	30
Mounting tools - Profile gasket – PEEK gasket .....	31
SVP bottom seat valve, manually operated - Profile gasket – PEEK gasket .....	32
SVP bottom seat valve with bevelled wheel drive - Profile gasket – PEEK gasket .....	34
Pneum. SVPbottom seat valve - Profile gasket – PEEK gasket .....	36
Assembly instructions - Profile gasket – PEEK gasket .....	38
Assembly .....	38
Installation .....	38
Pneum. actuator .....	40
Operation: air opened – spring closed .....	40
Pneum. actuator with Booster .....	41
Mounting the booster subsequently .....	41
Montage Prozess-Steuerkopf Typ 1066 .....	43
Montage Prozess-Steuerkopf IntelliTop® Typ 8680 .....	44
<b>Start-up</b> .....	<b>45</b>
Functional test .....	45
Manual version .....	45
Pneumatic version .....	45
Leak test .....	45

<b>Maintenance</b> .....	<b>46</b>
Before maintenance .....	46
Inspection .....	46
Preventive maintenance .....	46
<b>Disorder - trouble shooting</b> .....	<b>47</b>
<b>Disposal</b> .....	<b>48</b>
Before disposal .....	48
Parts of SVP bottom seat valve .....	48
SVP bottom seat valve disposal .....	48
<b>List of spare parts</b> .....	<b>49</b>
SVP bottom seat valve - Profile gasket – O-ring .....	49
SVP bottom seat valve - Profile gasket – PEEK gasket .....	53
Pneum. actuator .....	57
Operation: air opened – spring closed .....	57
Booster .....	59
<b>EC Declaration of Incorporation</b> .....	<b>60</b>
<b>Declaration of Conformity</b> .....	<b>61</b>
<b>EC manufacturer’s declaration for the use in explosion area</b> .....	<b>62</b>
<b>Service adress</b> .....	<b>64</b>

## Safety instructions



***This symbol indicates a direct and immediate danger to the life and health of persons***

***Failure to observe these warnings may result in serious damage to health, up to and including life-threatening injuries which may or may not be fatal.***



***This symbol indicates a potentially hazardous situation!***

***Failure to observe these warnings may result in less serious injuries, or damage to material property.***



**This sign draws your attention to important information about the proper use of the SVP bottom seat valve. It is essential for this information to be observed.**

**Failure to observe these instructions may cause malfunctions in the valve or in its vicinity.**

## General

- ⇒ SVP bottom seat valves from Südmo Components GmbH are manufactured in accordance with state-of-the-art standards and the recognized safety rules. However, these SVP bottom seat valve may constitute a hazard if used by operating personnel improperly or for a purpose other than the intended one. This may result in a risk to life and limb of the user or of third parties, or cause damage to the SVP bottom seat valve and other material property.
- ⇒ Each person concerned with installation, commissioning, operation and maintenance of this SVP bottom seat valve must have read and understood the complete operating instructions, and in particular all safety instructions.
- ⇒ In addition to these operating instructions, the following are of course also valid:
  - pertinent accident prevention regulations
  - generally recognized safety rules
  - national regulations of the country of use
  - in-house work and safety regulations.

## Maintenance

- ⇒ Our SVP bottom seat valves should be maintained and commissioned only by qualified personnel. Qualified personnel in the sense of the operating instruction are persons which are familiar with assembly, commissioning and operation of this product and have corresponding qualifications
  - Training or instruction according to the current standards of the security techniques concerning corresponding care and use of the security devices
  - First Aid training
  - Plants with explosion protection:  
Training, instruction or authorization to effect works on explosive plants (pay attention to ATEX requirements).

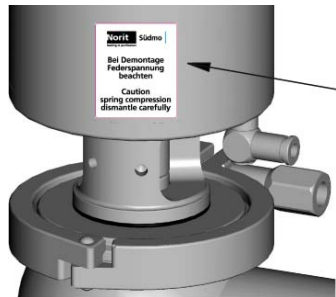

Sketch A

- ⇒ Before starting maintenance please make sure that:
- discharge of the pipeline
  - please effect only when there is no pressure and no product in the pipeline
  - to be informed about possible dangers which can occur due to the product and to take the corresponding measures (security glove, protecting glasses)
  - cool down the components if required
  - exclude commissioning of the plant by a third party.
  - counteract against cushion pressure which can occur in isolated pipelines
  - do assembly in accordance with assembly instructions.
  - if the closing springs are not preloaded when removing the actuator, there might be danger of injury when the clamping joint is loosened because the drive releases spring tension (see label – sketch A)
  - switch off the power supply.
  - take the SVP bottom seat valve out of the pipeline section if possible.
- ⇒ Any method of working that impairs the safety and function of the SVP bottom seat valve must be avoided.

### Modification of the SVP bottom seat valve

- ⇒ The user is obligated to ensure that the SVP bottom seat valve is always operated in accordance with its designated use and only by safety-conscious persons who are fully aware of the risks involved in its operation. Changes to the SVP bottom seat valve which impair its functioning or safety must be reported immediately. The user is obligated to ensure that the SVP bottom seat valve is always operated in technically perfect condition.



Danger

***Modification of the SVP bottom seat valve is strictly prohibited.***

### SVP bottom seat valves with feedback

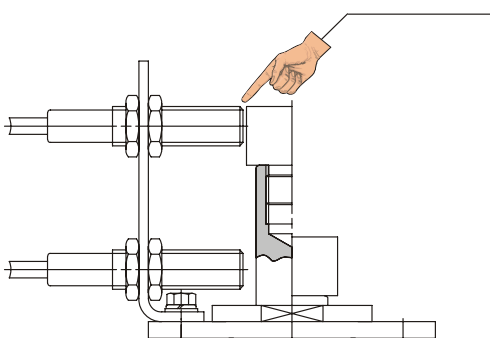

Danger

***Don't put fingers into check-back signal.***

⇒ ***Accident risk.***

***Fingers can be crushed or cut off.***

### Storage

- ⇒ Store the valve in a dry place and protect it against external conditions.
- ⇒ Prior to any handling (dismantling of housings / actuators) store valves at least for 24 h in a dry place at a temperature of  $\geq 5^{\circ}$  C.

### Operation



Danger

- **Never touch the valve or piping system when hot products are in processing or during sterilization.**
- **Observe strictly the technical data.**
- **We cannot be held liable for an incorrect use of the valve.**

### Spare parts



Caution

- **Please use only original Norit Südmo spare parts**
- **Norit Südmo spare parts see list of spare parts**
- **exclusion of liability by using other spare parts.**

### Risk assessment

- ⇒ All safety instructions in these operating instructions result from the risk assessment for the SVP-bottom seat valve.

**Technical data**

**Dimensions**

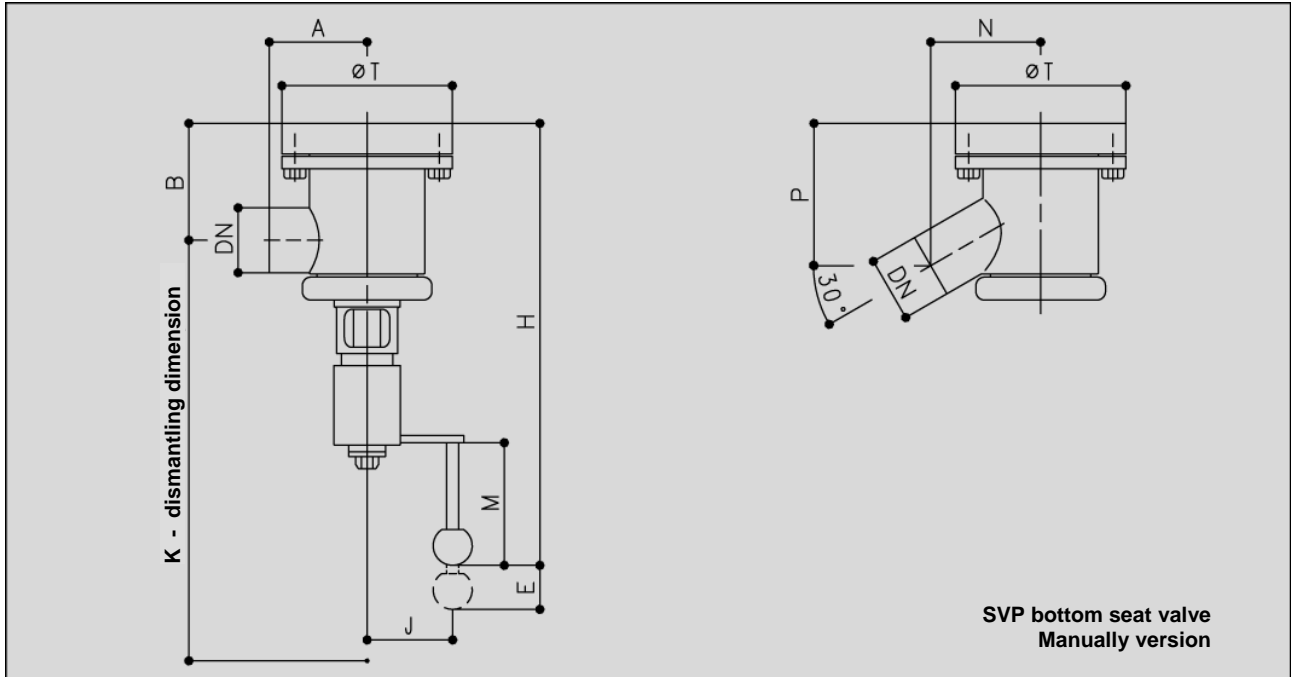

DN	Tube	A	B	E	J	K	M	N	P	øT
<b>Metric</b>										
25	ø29 x 1,5	70	79	20	70	365	100	70	94	129,5
40	ø41 x 1,5	70	90	20	70	390	100	80	111	129,5
50	ø53 x 1,5	80	96	25	70	405	100	90	116	139,5
65	ø70 x 2,0	90	113	30	100	470	100	100	132	169,5
80	ø85 x 2,0	100	133	40	100	505	100	110	153	179,5
100	ø104 x 2,0	120	161	40	100	550	100	140	188	209,5
<b>O.D. tube</b>										
1"	ø25,4 x 1,65	70	81	20	70	365	100	70	97	129,5
1 ½"	ø38,1 x 1,65	70	92	20	70	390	100	80	112,5	129,5
2"	ø50,8 x 1,65	80	97	25	70	405	100	90	118	139,5
2 ½"	ø63,5 x 1,65	0	115,5	30	100	470	100	100	135,5	169,5
3"	ø76,1 x 1,65	100	137	40	100	505	100	110	157,5	179,5
4"	ø101,6 x 2,11	120	162,5	40	100	550	100	140	189,5	209,5

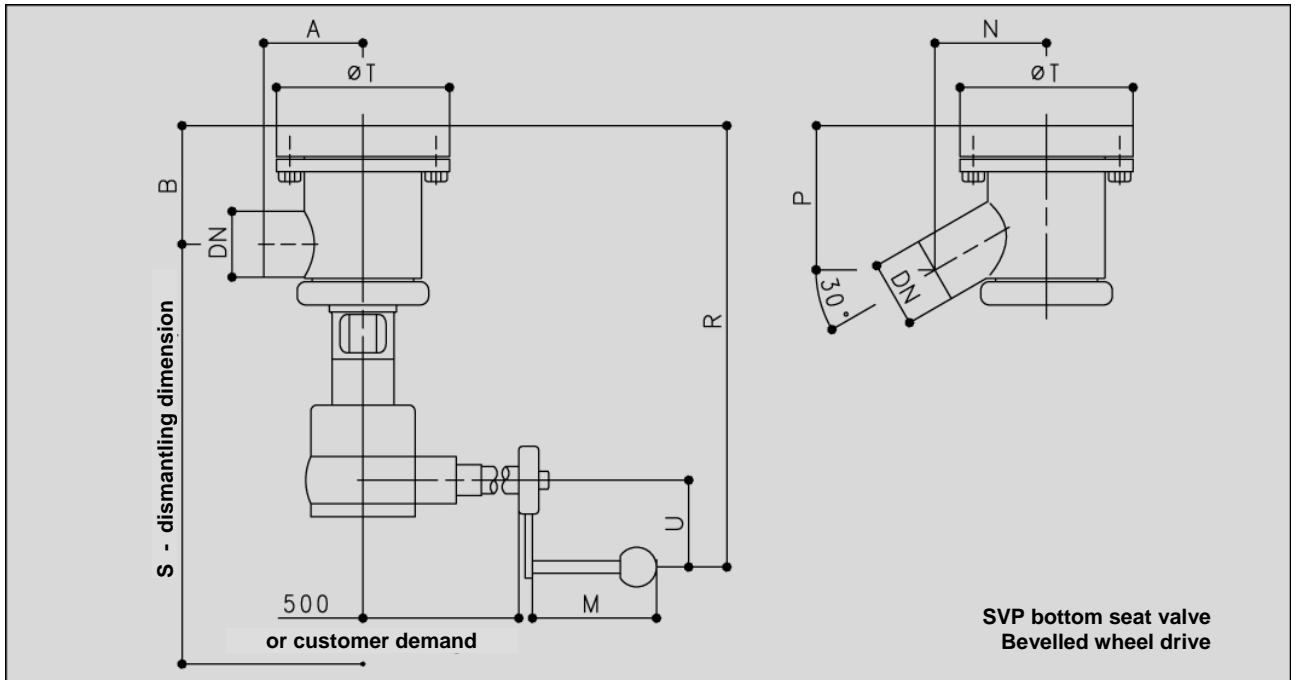

DN	Tube	A	B	M	N	P	R	S	øT	U
<b>Metric</b>										
25	ø29 x 1,5	70	79	100	70	94	337	340	129,5	70
40	ø41 x 1,5	70	90	100	80	111	355	370	129,5	70
50	ø53 x 1,5	80	96	100	90	116	366	380	139,5	70
65	ø70 x 2,0	0	113	100	100	132	391	415	169,5	70
80	ø85 x 2,0	100	133	100	110	153	469	490	179,5	100
100	ø104 x 2,0	120	161	100	140	188	507	530	209,5	100
<b>O.D. Tube</b>										
1"	ø25,4 x 1,65	70	81	100	70	97	337	340	129,5	70
1 ½"	ø38,1 x 1,65	70	92	100	80	112,5	355	370	129,5	70
2"	ø50,8 x 1,65	80	97	100	90	118	366	380	139,5	70
2 ½"	ø63,5 x 1,65	0	115,5	100	100	135,5	391	415	169,5	70
3"	ø76,1 x 1,65	100	137	100	110	157,5	469	490	179,5	100
4"	ø101,6 x 2,11	120	162,5	100	140	189,5	507	530	209,5	100

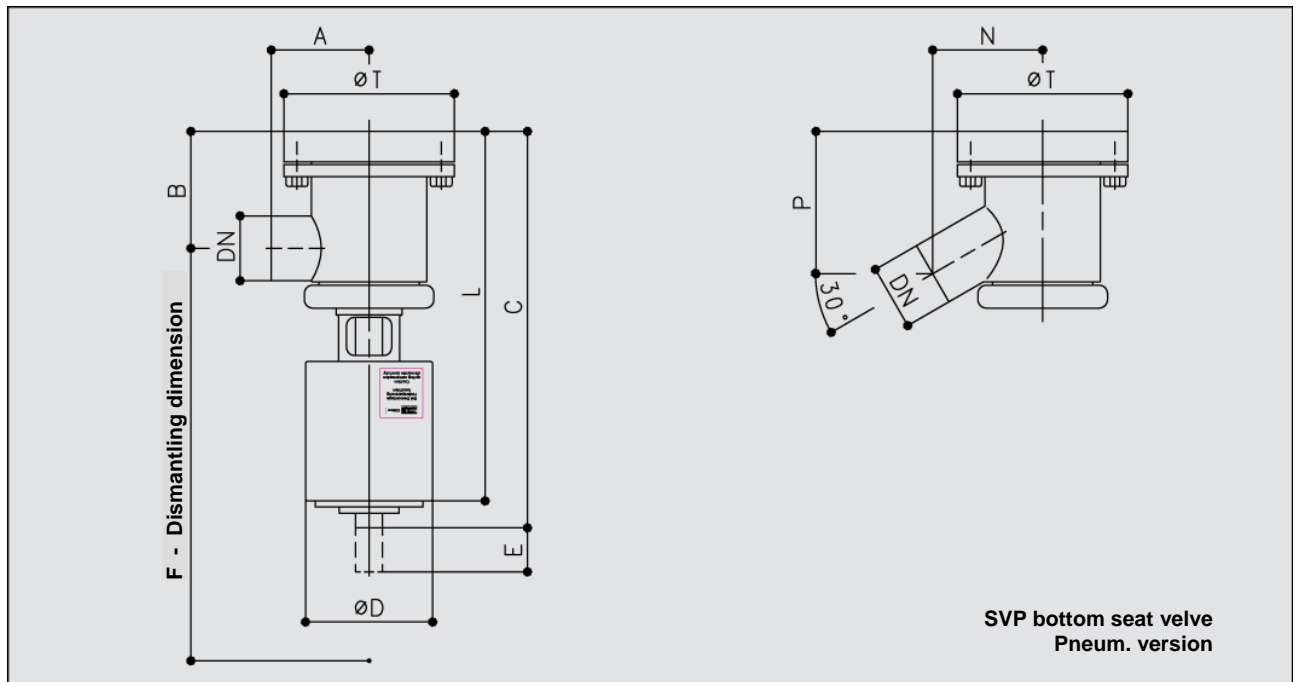

DN	Tube	A	B	C	øD	E	F	L	N	P	øT
<b>Metric</b>											
25	ø29 x 1,5	70	79	291	104	20	320	273	70	94	129,5
40	ø41 x 1,5	70	90	308	104	20	345	290	80	111	129,5
50	ø53 x 1,5	80	96	315	104	25	360	302	90	116	139,5
65	ø70 x 2,0	0	113	384	129	30	440	371	100	132	169,5
80	ø85 x 2,0	100	133	471	154	40	535	458	110	153	179,5
100	ø104 x 2,0	120	161	508	154	40	575	495	140	188	209,5
<b>O.D. Tube</b>											
1"	ø25,4 x 1,65	70	81	291	104	20	320	273	70	97	129,5
1 ½"	ø38,1 x 1,65	70	92	308	104	20	345	290	80	112,5	129,5
2"	ø50,8 x 1,65	80	97	315	104	25	360	302	90	118	139,5
2 ½"	ø63,5 x 1,65	0	115,5	384	129	30	440	371	100	135,5	169,5
3"	ø76,1 x 1,65	100	137	471	154	40	535	458	110	157,5	179,5
4"	ø101,6 x 2,11	120	162,5	508	154	40	575	495	140	189,5	209,5

**Valve use**

Application:	Shut-off valve for wesels
For use in:	keimarme Prozesse
Sut-off tightness:	6 bar max.
Vacuum:	Leakage rate (mbar x l/s) = $1,5 \times 10^{-5}$

**Materials**

**Seal materials SVP bottom seat valve - profile gasket – O-ring**

⇒ EPDM

Temperature for continuous application in air	-40° C to +130° C	
Resistant to:	Hot water	to 100° C
	Steam	to 130° C for continuous application, to 150° C for short time
	Wort	to 100° C
	Sodium hydroxide	to 100° C and concentration to 5 %
	Nitric acid	to 60° C and concentration to 3 %
	Peracetic acid	to 80° C and concentration to 0,7 %
	Raspberry flavor	room temperature
	Cherry flavor	room temperature

⇒ HNBR

Temperature for continuous application in air	-25° C to +130° C	
Resistant to:	Hot water	to 100° C
	Steam	to 130° C for continuous application, to 150° C for short time
	Sodium hydroxide	to 100° C and concentration to 5 %
	Nitric acid	to 60° C and concentration to 1,5 %

⇒ FPM

Temperature for continuous application in air	-20° C to +200° C	
Resistant to:	Hot water:	to 80° C
	Sodium hydroxide:	to 60° C and concentration to 2,5 %
	Peracetic acid:	room temperature and concentration to 0,7 %
	Orange flavor	room temperature
	Mandarin flavor	room temperature

**Seal materials SVP bottom seat valve - profile gasket – PEEK gasket**

PEEK natur / EPDM

Temperature for continuous application in air:	-25° C bis +130° C	
Resistant to		
Hot water	to 100° C	
Steam	to 130° C for continuous application, to 150° C for short time	
Wort:	to 100° C	
Sodium hydroxide	to 100° C and concentration to 5 %	
Nitric acid	to 60° C and concentration to 3 %	
Peracetic acid	to 80° C and concentration to 0,7 %	
Raspberry flavor	room temperature	
Cherry flavor	room temperature	



**The application parameters depend on:**

- ⇒ application duration per day
- ⇒ switching intervals
- ⇒ kind of product, temperature etc...
- ⇒ type of cleaning (CIP / SIP)

**Stainless steel**

In contact with product: 1.4404

Not in contact with product: 1.4301

**CIP-Cleaning**



- ⇒ Valve inner chambers must be cleaned regularly
- ⇒ Observe the safety information sheets issued by the detergent manufacturers !
- ⇒ Only use detergents which are non-abrasive and non-aggressive towards seals and stainless steel.

**Surfaces**

Surfaces in contact with product:  $R_a \leq 0,8 \mu\text{m}$   
Optional: E-polished  
Surfaces not in contact with product: bright-turned,  
 $R_a \leq 1,6 \mu\text{m}$

**Pneum. actuator**

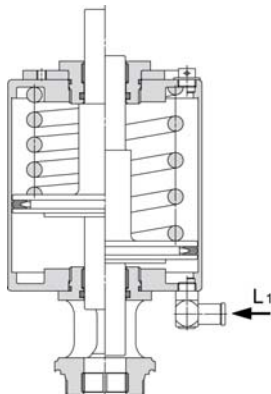

**Function air opened – spring closed**

- ⇒ Position "closed"
  - ⇒ control air pressure 0 bar on connection L<sub>1</sub>.
  - ⇒ safety position
- ⇒ Position "open"
  - ⇒ control air pressure 6 bar on connection L<sub>1</sub>.

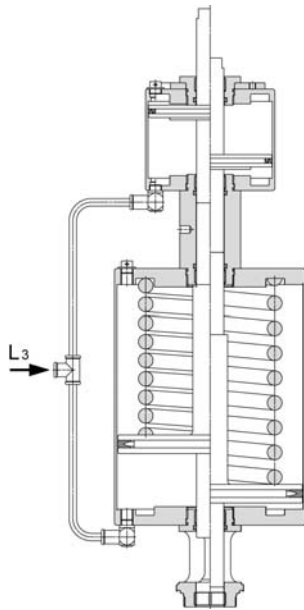

**SVP actuator with booster**

- ⇒ Position "closed"
  - ⇒ control air pressure 0 bar on connection L<sub>3</sub>.
  - ⇒ safety position
- ⇒ Position "open"
  - ⇒ control air pressure min. 3 bar on connection L<sub>3</sub>.

**Control systems**

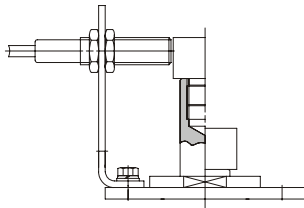

**Single feedback**

- ⇒ signal: open or closed valve position
- ⇒ inductive feedback - thread M 12 according to customer order
- ⇒ feedback data - refer to the data sheet of the manufacturer of the feedback
- ⇒ mounting set for check-back signal - order number 2125977

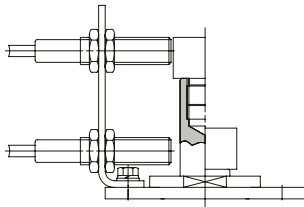

**Double feedback**

- ⇒ signal: open and closed valve position
- ⇒ inductive feedback - thread M 12 according to customer order
- ⇒ feedback data - refer to the data sheet of the manufacturer of the feedback
- ⇒ mounting set for check-back signal - order number 2125977



**Process control head type 1066**

- Technical data refer to BA1066
- Pneum. connections refer to BA1066
- Electrical connections refer to BA1066
- Maintenance refer to BA1066



**Process control head IntelliTop® type 8680**

- Technical data refer to BA 8680
- Pneum. connections refer to BA 8680
- Electrical connections refer to BA 8680
- Maintenance refer to BA 8680

**Electrical and pneumatic connections**

**Electrical connections**

Connect up the electrical and pneumatic systems after installing the valve.



Danger

***Only qualified personnel may do electrical installation***

- ⇒ Observe VDE, IEE, IEC power utility and other locally applicable regulations.
- ⇒ Before connecting it up, check to see whether operating voltage and current match specifications.

**Pneumatic connections**

- ⇒ Angular screw-in-union G 1/8, air hose PE ø 6/4
- ⇒ USA: Angular screw-in-union G 1/8, air hose PE 1/4" (ø6,35)

**Air hose**

Use always the hose quality according to Norit Südmo order no. 0490227 (6/4 hose) and 0735563 (8/6 hose) or equivalent:

- ⇒ Air hose black
- ⇒ Material: Polyamid 12  
Linear coefficient of expansion:  $15 \times 10^{-5}$   
Version according to DIN73378 soft
- ⇒ Max. operating pressure: AD 6/ ID 4 = 27 bar  
AD 8/ ID 6 = 19 bar  
all pressure indications at 20°C, higher temperatures have a negativ effect on the max. operating pressure



- ⇒ **Use only calibrated hose lines with an outside diameter of 6mm or 1/4" or 8 mm or 5/16" (Tolerance +0,05/-0,1)**
- ⇒ **Cut the hose line only with a special hose cutter otherwise the hoses can be damaged.**
- ⇒ **During inappropriate cutting, the hose can leak at the cutting point which can cause a pressure loss.**
- ⇒ **The length of the hose must be calculated in a way that the hose cannot buckle. If the hose is once buckled it is permanently damaged. This can cause a pressure loss or an interruption of the air supply. Please see manufacturer's instruction regarding the minimum bending radius of the hose.**
- ⇒ **Insert the air hose tangentially into the connector and fix it. Avoid inclined hoist on the connector as the air hose may buckle and leakages can arise. This can cause a pressure loss or an interruption or the air supply.**

**Control air**

**Control air pressure**

SVP actuator	min. 6 bar – max. 8 bar
SVP actuator with booster	min. 3 bar – max. 8 bar
Process control head type 1066	refer to BA 1066
Process control head IntelliTop® type 8680	refer to BA 8680



**Only use clean and dry compressed air !**

**Control air**

acc. to DIN/ISO 8573.1

Solid content

Particle size	max. 5 µm
Particle density	max. 5 mg/m <sup>3</sup> (quality grade 3)

Water content

quality grade 3

Dew point	-20° C or at least 10° C at lowest ambient temperatures
-----------	--

Oil content

quality grade 3, preferable oil free, max. 25 mg oil 1 m<sup>3</sup> air

**Valve function**

**SVP bottom seat valve with manual drive**

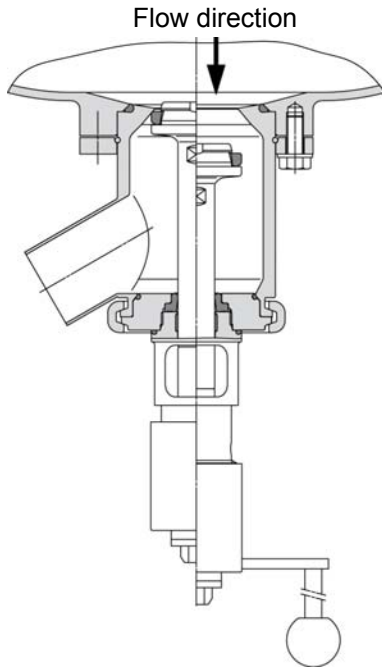

**Valve position „Closed“**

- ⇒ rotate the hand-crank clockwise to the catch
- ⇒ locking pressure against product pressure 6 bar.

**Valve open**

- ⇒ rotate the handwheel counter-clockwise to the catch
- ⇒ valve open

**SVP bottom seat valve with bevelled wheel drive**

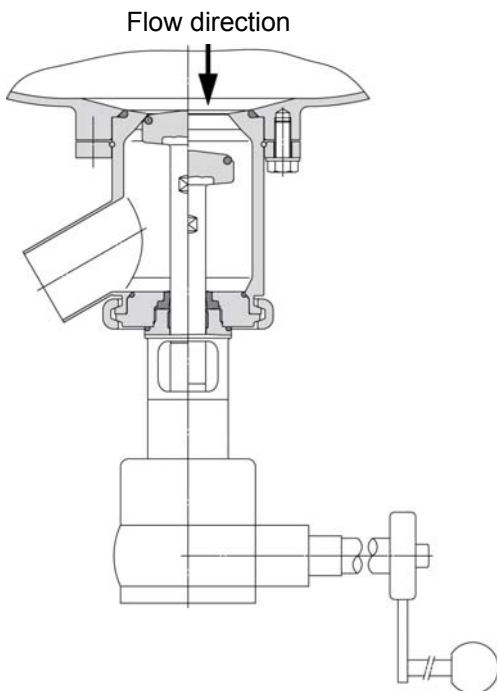

**Valve position „Closed“**

- ⇒ rotate the hand-crank clockwise to the catch
- ⇒ locking pressure against product pressure 6 bar.

**Valve open**

- ⇒ rotate the hand-crank counter-clockwise to the catch
- ⇒ valve open

**SVP bottom seat valve air opened – spring closed**

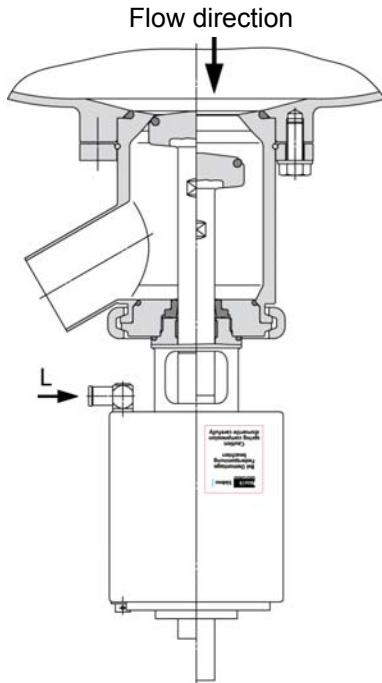

**Valve position „Closed“**

- ⇒ control air pressure 0 bar on air connection L<sub>1</sub>
- ⇒ safety position
- ⇒ locking pressure against product pressure 6 bar.

**Valve open**

- ⇒ control air pressure 6 bar on air connection L<sub>1</sub>
- ⇒ valve open

**Valve connection piping**

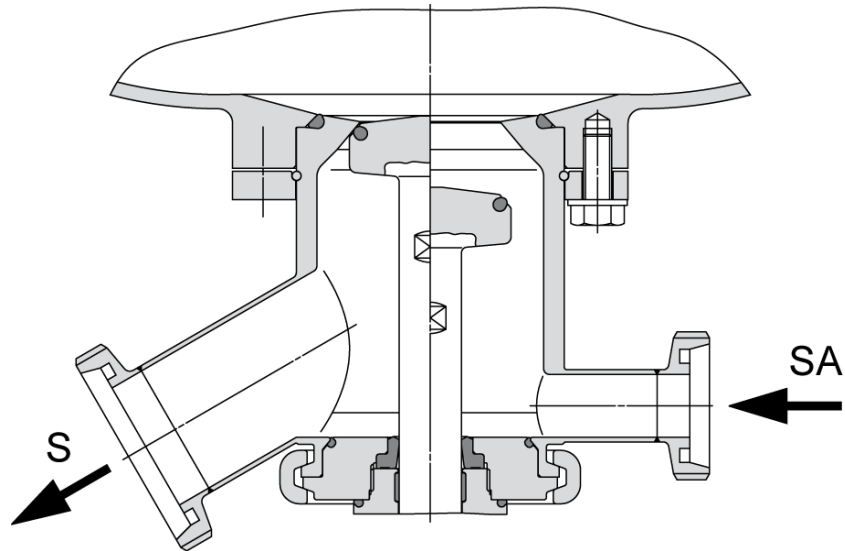

**Installation position**

Vertical, horizontal

Ensuring that product can drain from valve and piping.

**Valve connections**

Separable flange connection on tank side - loose flange welded on tank side.

Connections

- |                         |                                 |
|-------------------------|---------------------------------|
| Outlet side (S)         | ⇒ welding end                   |
|                         | ⇒ separable connection required |
| Rinsing connection (SA) | ⇒ welding end                   |
|                         | ⇒ separable connection required |

Welding instructions see page 19.

**Installation instructions**

Dismantle valve in accordance with page 21.



- ⇒ **Remove seals before welding.**
- ⇒ **Valve housing must be free from stress and distortions when welded.**
- ⇒ **Welding works have to be effected only by approved qualified personnel (DIN 287-1 W11).**
- ⇒ **Do not allow any foreign bodies to enter the piping.**

**Installation instructions weld-in flange**

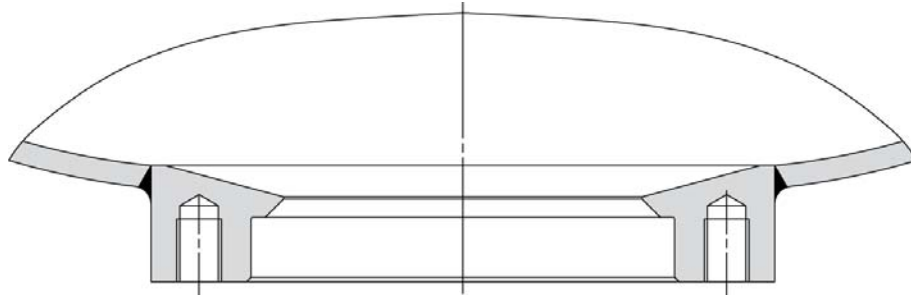

Caution

- ⇒ **Block flange must be free from stress and distortions when welded.**
- ⇒ **Welding works have to be effected only by approved qualified personnel (DIN 287-1 W11)..**

## Installation instructions

### General remarks

We strongly recommend that the fittings should be installed by specially trained, qualified personnel.



Caution

***Welding works have to be effected only by approved qualified personnel (DIN 287-1 W11).***

We cannot be held liable for any loss damage or injury resulting from incorrect installation.

### Delivery condition

- ⇒ Factory-tested and adjusted.
- ⇒ Ready for installation or for welding into the piping.

## Installation instructions

### Installation space

Determine and define the connection axes before starting installation work. Observe the installation dimensions specified in the dimensional drawings.

Ensure that there is sufficient space available for both operation and maintenance, which may include removal.

### Installation

Make sure that the fittings and piping are not subjected to tensile or compressive stresses.

## Welding instructions

### Area of application

Welding of fittings into pipes according to DIN 11850 Reihe 1, 2; OD-Tube; DIN EN ISO 1127

### Welding technique

TIG (tungsten inert-gas welding)

### Type of welding

- ⇒ Preparation of the welding seam according to DIN 2559 (groove shape I / for I-groove)
- ⇒ Welding seams corresponding to DIN EN ISO 5817 → evaluation group B (high)

## Weld preparation

Saw off the pipe ends evenly and at right angles, and debur them (pipe saw M882). Align the welding ends of the valve body and piping radially and axially, ensuring they are fitted flush together (centering device).



**There must be no gap at the flush-fitted welding ends as the corrosion resistance of the welded joint would be impaired by the escaping forming gas.**

### Welding

Connect the forming gas. Tack at 3 or 4 points. Type of welding: TIG-manual or orbital (automatic welding).

### Weld filler materials

Material allocation

Material of parts to be welded	Suitable weld filler materials		
	1.4430	1.4440	1.4519
1.4404	X		
1.4435	X	X	X
1.4571	X	X	

### Weld finishing

#### Interior

Weld finishing not required. Improvement of surface finish by grinding (at accessible points).

#### Exterior

Weld finishing methods

- ⇒ pickling - dispose pickling paste correctly
- ⇒ brushing
- ⇒ grinding
- ⇒ polishing

### Cleaning

Clean thoroughly before assembly.

### Assembly

Assemble the fittings in accordance with the assembly instructions.

## Dismantling – Assembly

### Before disassembly

Do assembly in accordance with assembly instructions.

Please always take the following steps before loosening the valve connections and clamp connection on the valve housing:



- ⇒ **ensure that there is no work being done in that area when doing service and maintenance work.**
- ⇒ **evacuate all pipeline elements leading to the SVP bottom seat valve and clean or rinse if necessary.**
- ⇒ **shut off the control air if not required for disassembly.**
- ⇒ **Preload closing springs with auxiliary assembly air when removing the actuator of spring-closed valves .**
- ⇒ **if the closing springs are not preloaded when removing the actuator, there might be danger of injury when the clamping joint is loosened because the drive releases spring tension.**
- ⇒ **switch off the power supply.**
- ⇒ **take the SVP bottom seat valve out of the pipeline section if possible.**

Before assembly, clean and grease the sliding surfaces and lubricate the sealing elements.

Seal materials	Grease type
EPDM	PARALIQ GTE 703
HNBR	PARALIQ GTE 703
FPM	PARALIQ GTE 703
PEEK	No grease
NBR	RENOLIT SI 410 M



- ⇒ **if a different grease is used  
→ it may attack seals.**
- ⇒ **Use of grease with PEEK seal elements not necessary.**
- ⇒ **please do not use mineral or animal greases.**
- ⇒ **Don't use grease based on petroleum.**

**SVP bottom seat valves with feedback**

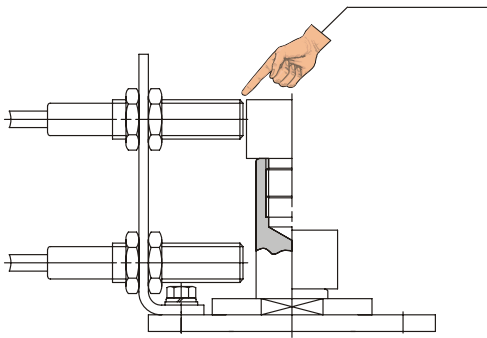

Danger

**Don't put fingers into check-back signal.**

⇒ **Accident risk.**

**Fingers can be crushed or cut off.**

**Spare parts**





Caution

**Please use only original Norit Südmo spare parts**

- **Norit Südmo spare parts see list of spare parts**
- **exclusion of liability by using other spare parts.**

**Mounting tools - Profile gasket – O-ring**

Tool	for	Order no.	Use
Piercer ø6 	DN 25 – DN 100 DN 1" – DN 4"	2123663	SVP bottom seat valve, manually operated
forked open jaw wrench SW 17 – 19 	DN 25 – DN 100 DN 1" – DN 4"	0098558	SVP bottom seat valve, manually operated Pneum. SVP bottom seat valve
hock wrench with finger 45/50 	DN 25 – DN 100 DN 1" – DN 4"	2153550	SVP bottom seat valve, manually operated Pneum. SVP bottom seat valve

**SVP bottom seat valve, manually operated - Profile gasket – O-ring**

**Disassembly**

In succession 1.1. – 1.13.

**Assembly**

In succession 1.13. – 1.1.

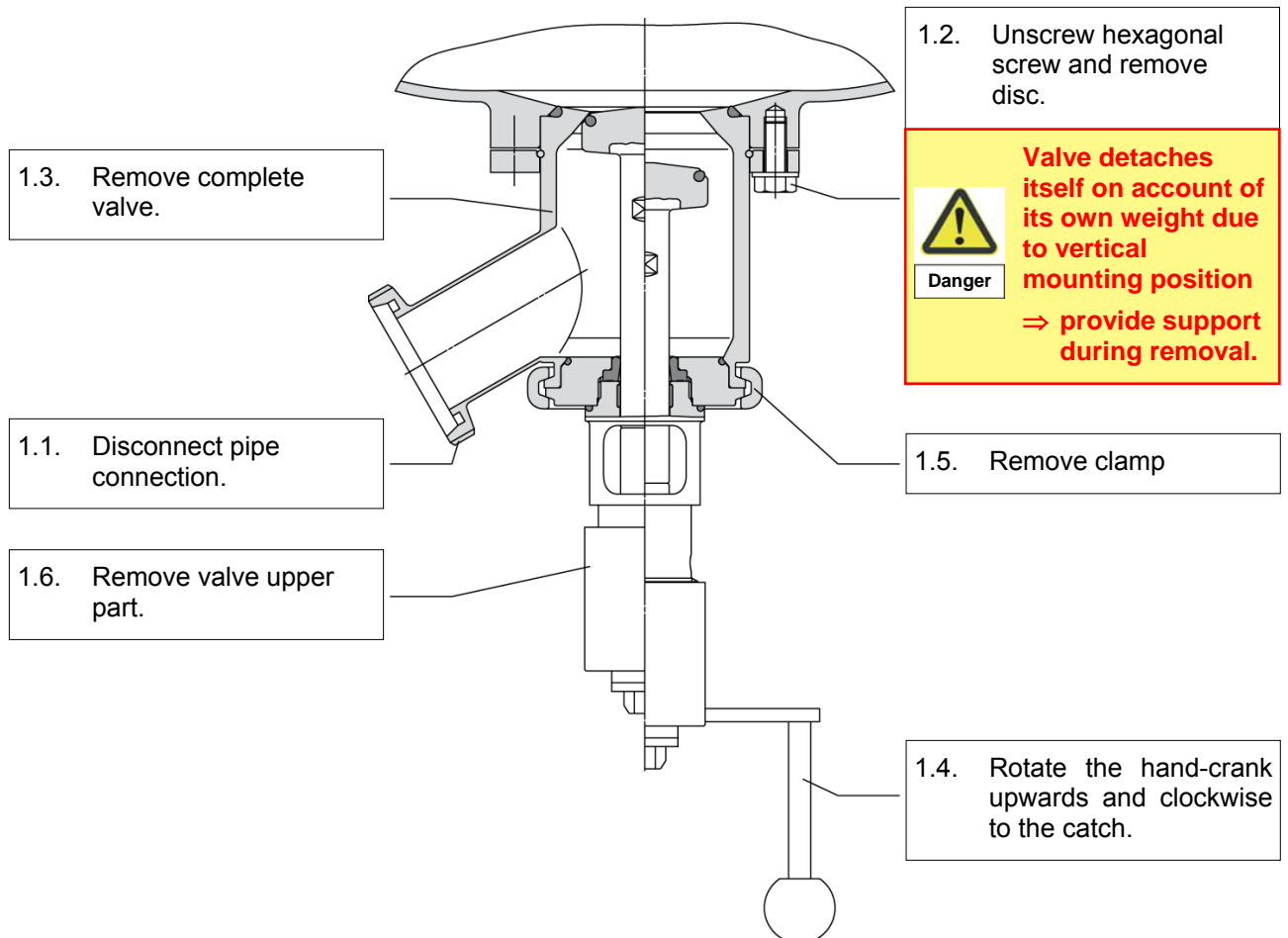

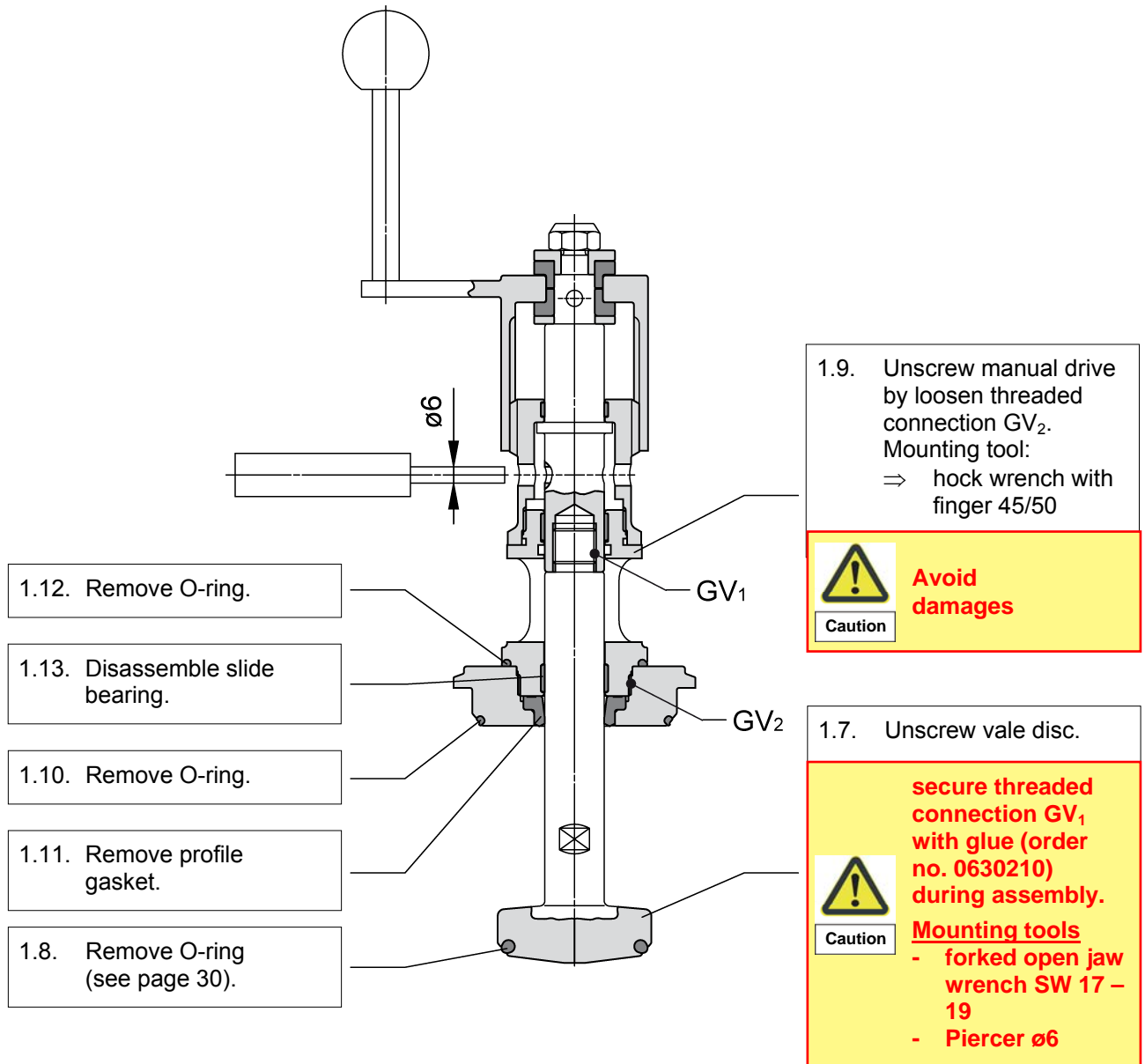

**SVP bottom seat valve with beveled wheel drive - Profile gasket – O-ring**

**Disassembly**

In succession 2.1. – 2.13.

**Assembly**

In succession 2.13. – 2.1.

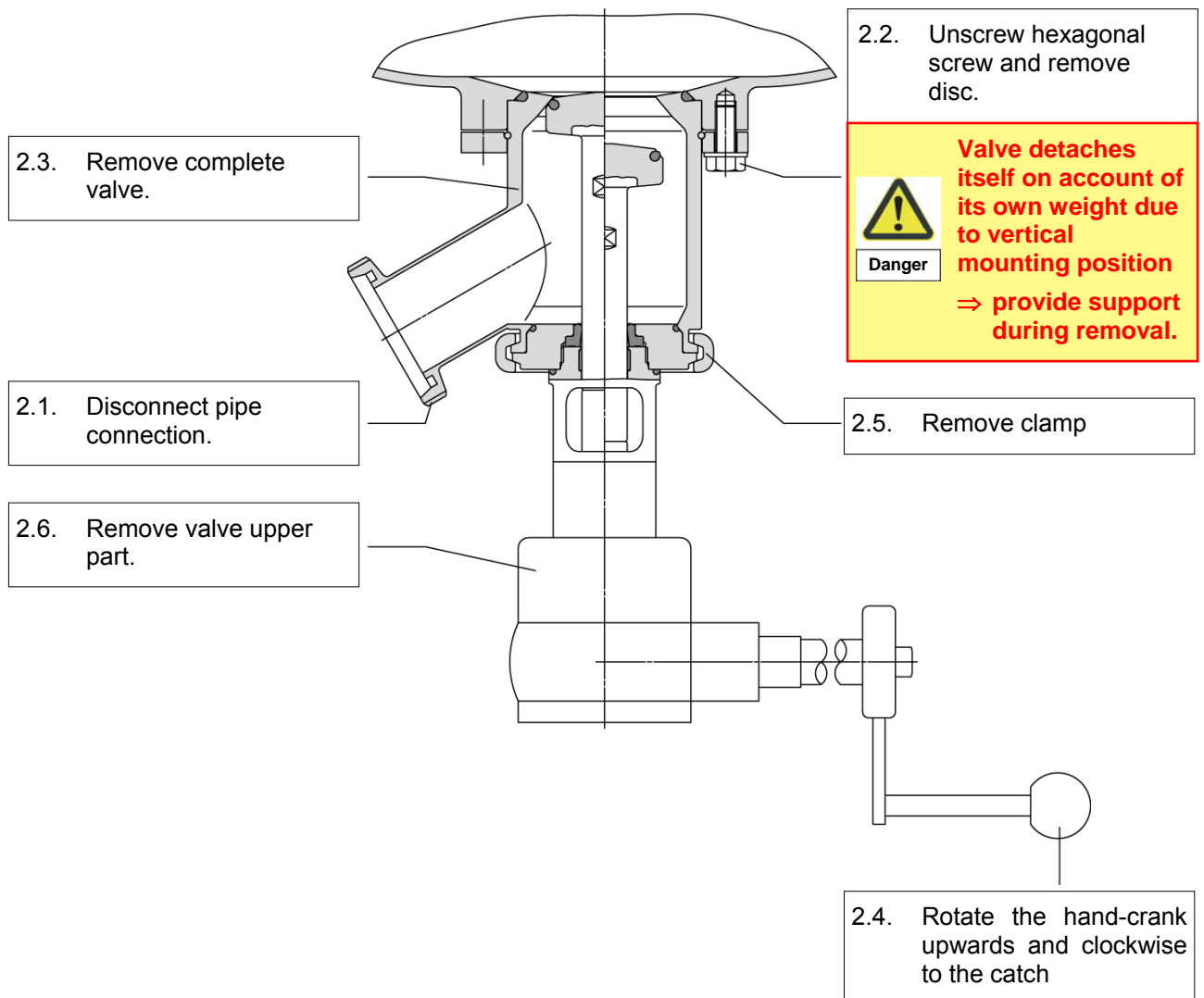

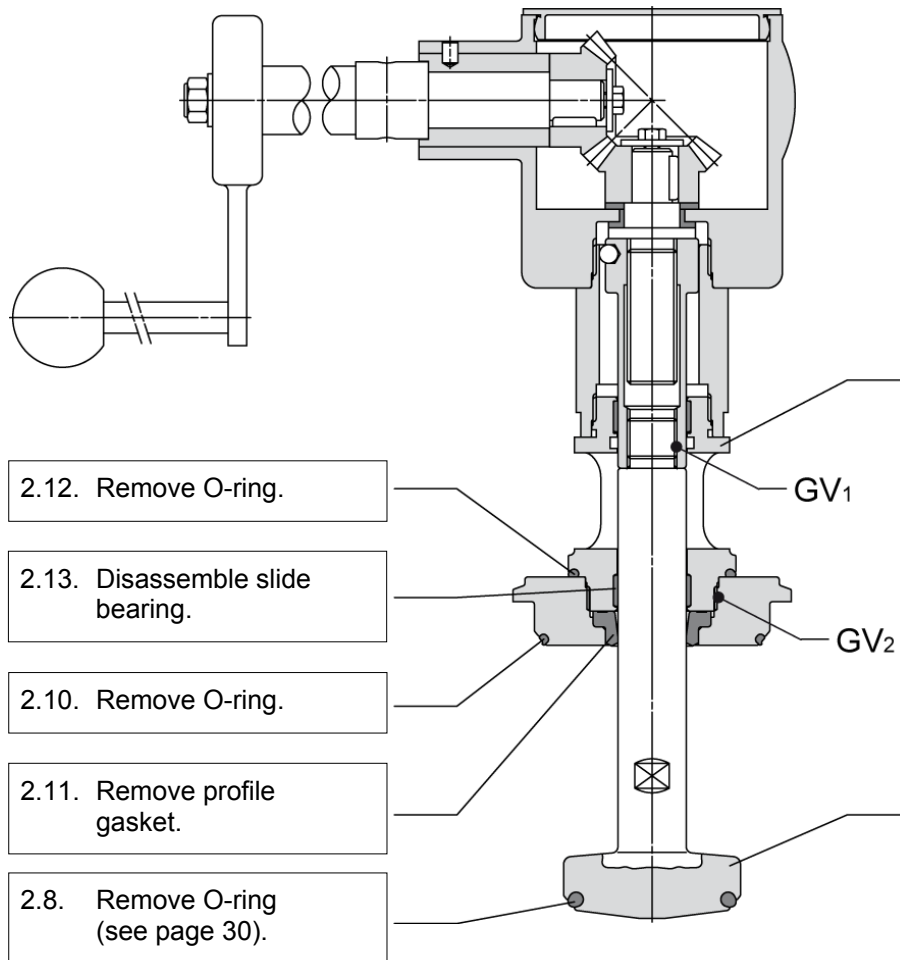

2.12. Remove O-ring.

2.13. Disassemble slide bearing.

2.10. Remove O-ring.

2.11. Remove profile gasket.

2.8. Remove O-ring (see page 30).

2.9. Unscrew bevelled wheel drive by loosen threaded connection GV<sub>2</sub>.  
Mounting tool:  
⇒ hock wrench with finger 45/50

 **Avoid damages**  
Caution

2.7. Unscrew vale disc.

 **secure threaded connection GV<sub>1</sub> with glue (order no. 0630210) during assembly.**  
**Mounting tools**  
- forked open jaw wrench SW 17 – 19  
- Piercer ø6

**Pneum. SVP bottom seat valve - Profile gasket – O-ring**

**Disassembly**

In succession 3.1. – 3.15.

Steps 3.5. and 3.7. only required with the drive function air-opened – spring closed.

**Assembly**

In succession 3.15. – 3.1.

Steps 3.5. and 3.7. only required with the drive function air-opened – spring closed.

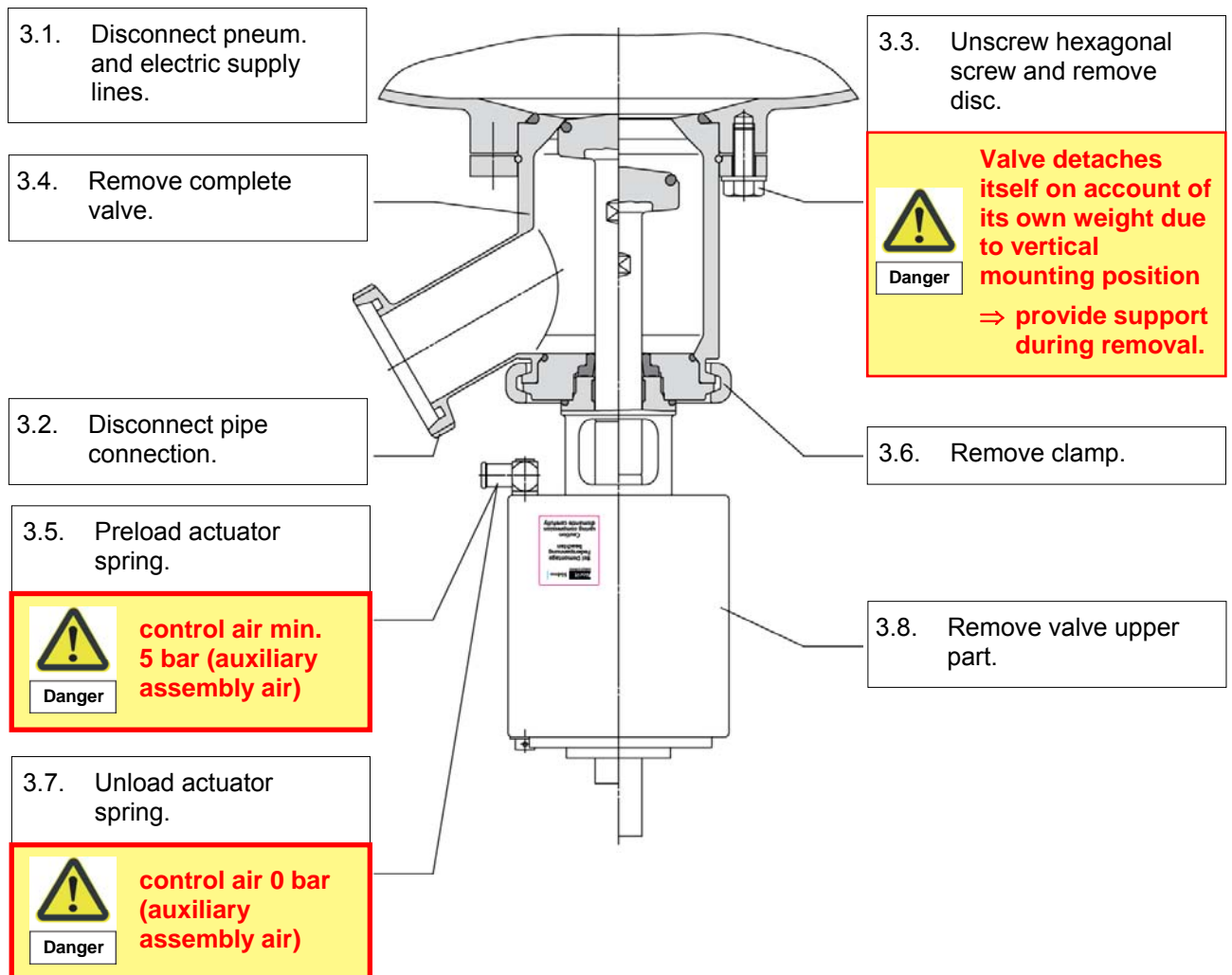

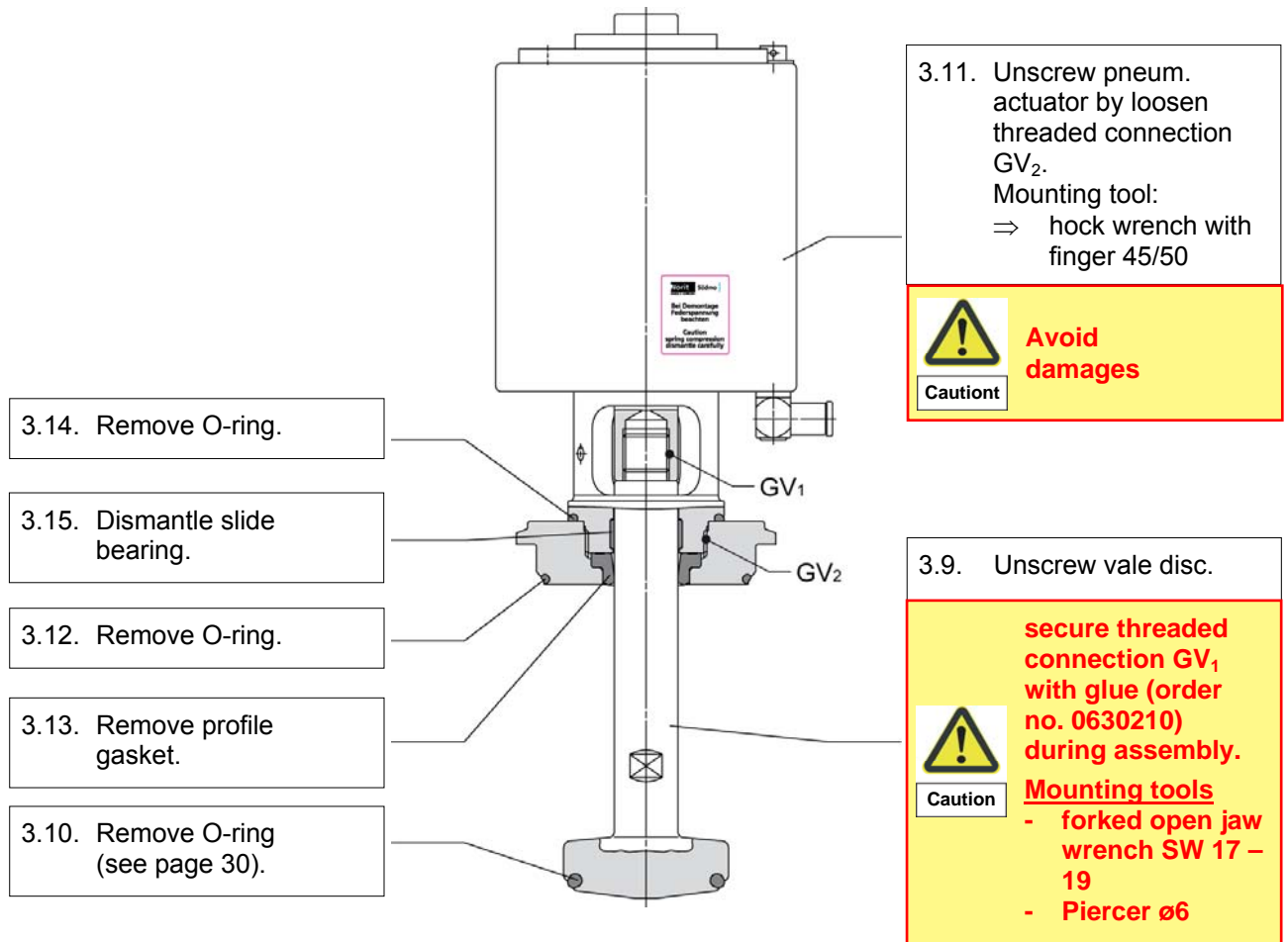

**Assembly instructions - Profile gasket – O-ring**

Use assembly device for clamping to avoid damage to valve disc.

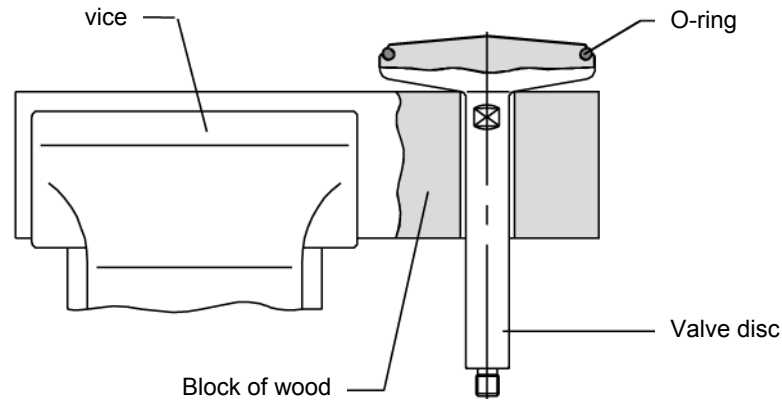

**Removal**

- ⇒ O-ring is installed in positive contact under pretension.
- ⇒ It must be removed as shown in drawing.

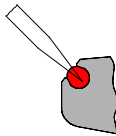

**Don't damage sealing groove (edges of groove)..**

**Installation**





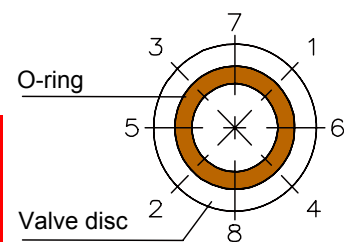

- ⇒ Press O-ring in sequence 1 – 2, 3 – 4 etc. into groove.
- ⇒ Roll O-ring section by section 1 – 6, 5 – 2 etc into groove.
- ⇒ Use round object of plastic or wood for installation.



**Avoid drilling and damaging the O-ring by assembly.**

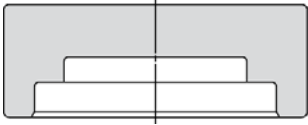

**Mounting tools - Profile gasket – PEEK gasket**

Tool	for	Order no.	Use
<p>Piercer ø6</p> 	<p>DN 25 – DN 100 DN 1" – DN 4"</p>	2123663	SVP bottom seat valve, manually operated
<p>forked open jaw wrench SW 17 – 19</p> 	<p>DN 25 – DN 100 DN 1" – DN 4"</p>	0098558	SVP bottom seat valve, manually operated Pneum. SVP bottom seat valve
<p>hock wrench with finger 45/50</p> 	<p>DN 25 – DN 100 DN 1" – DN 4"</p>	2153550	SVP bottom seat valve, manually operated Pneum. SVP bottom seat valve
<p>Soldering iron</p> 	<p>DN 25 – DN 100 DN 1" – DN 4"</p>		SVP bottom seat valve, manually operated Pneum. SVP bottom seat valve
<p>Punch</p> 	<p>DN 25 / DN 1" DN 40 / DN 1 1/2" DN 50 / DN 2" DN 65 / DN 2 1/2" DN 80 / DN 3" DN 100 / DN 4"</p>	<p>2152517 2152518 2152519 2152520 2152581</p>	SVP bottom seat valve, manually operated Pneum. SVP bottom seat valve
<p>Holding fixture</p> 	<p>DN 25 – DN 100 DN 1" – DN 4"</p>	2152582	SVP bottom seat valve, manually operated Pneum. SVP bottom seat valve

**SVP bottom seat valve, manually operated - Profile gasket – PEEK gasket**

**Disassembly**

In succession 4.1. – 4.13.

**Assembly**

In succession 4.13. – 4.1.

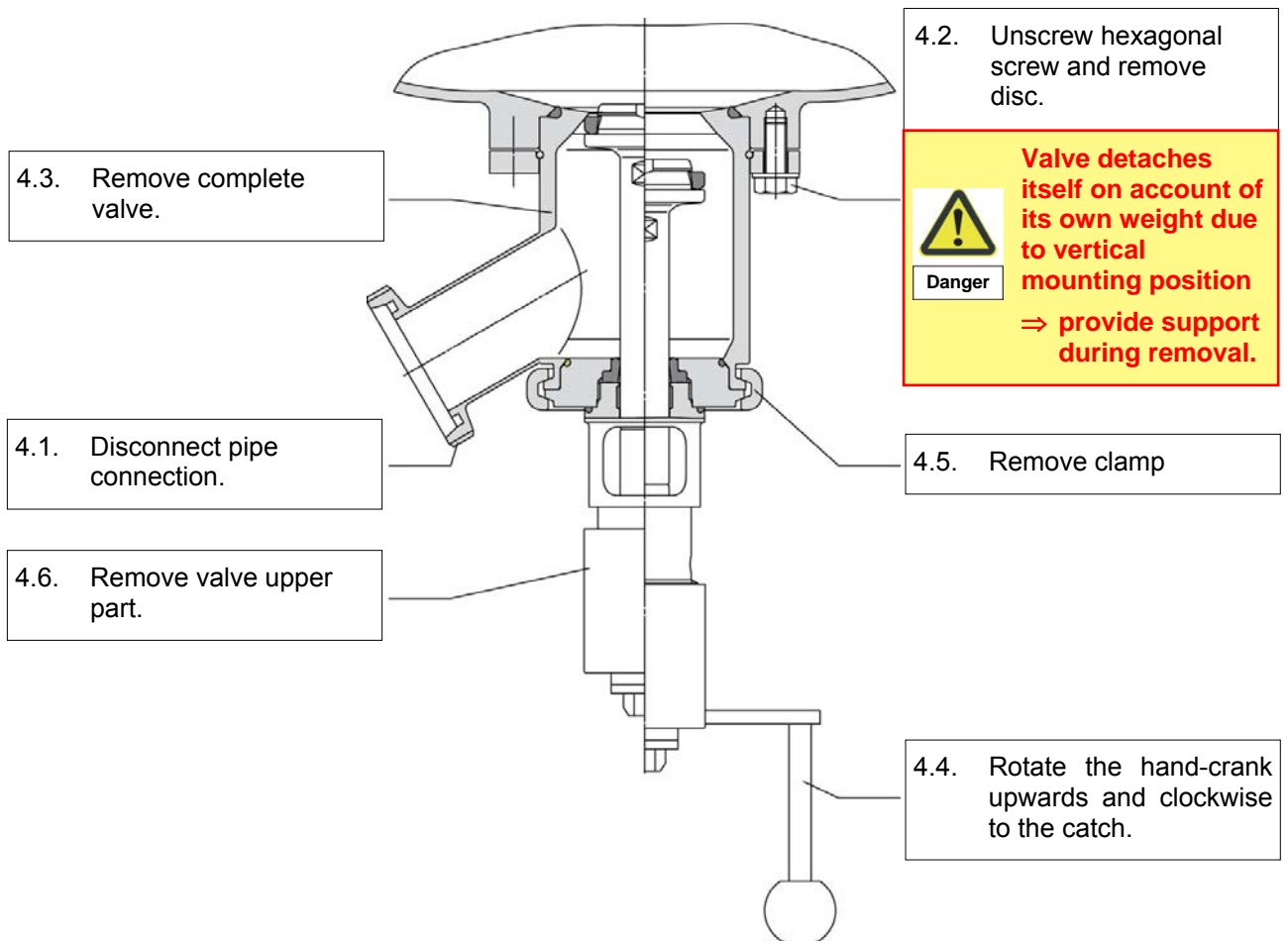

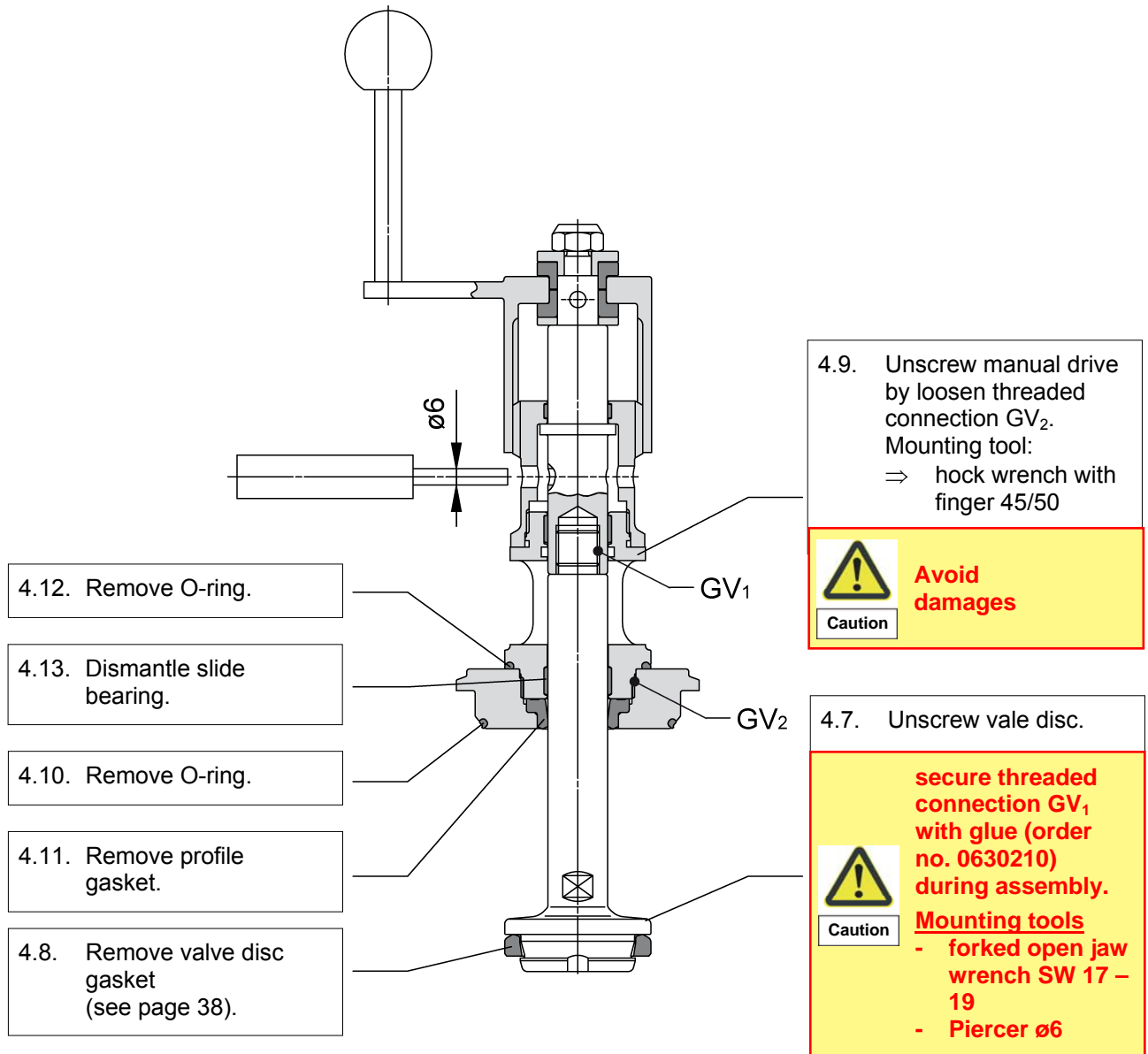

**SVP bottom seat valve wth bevelled wheel drive - Profile gasket – PEEK gasket**

**Disassembly**  
In succession 5.1. – 5.13.

**Assembly**  
In succession 5.13. – 5.1.

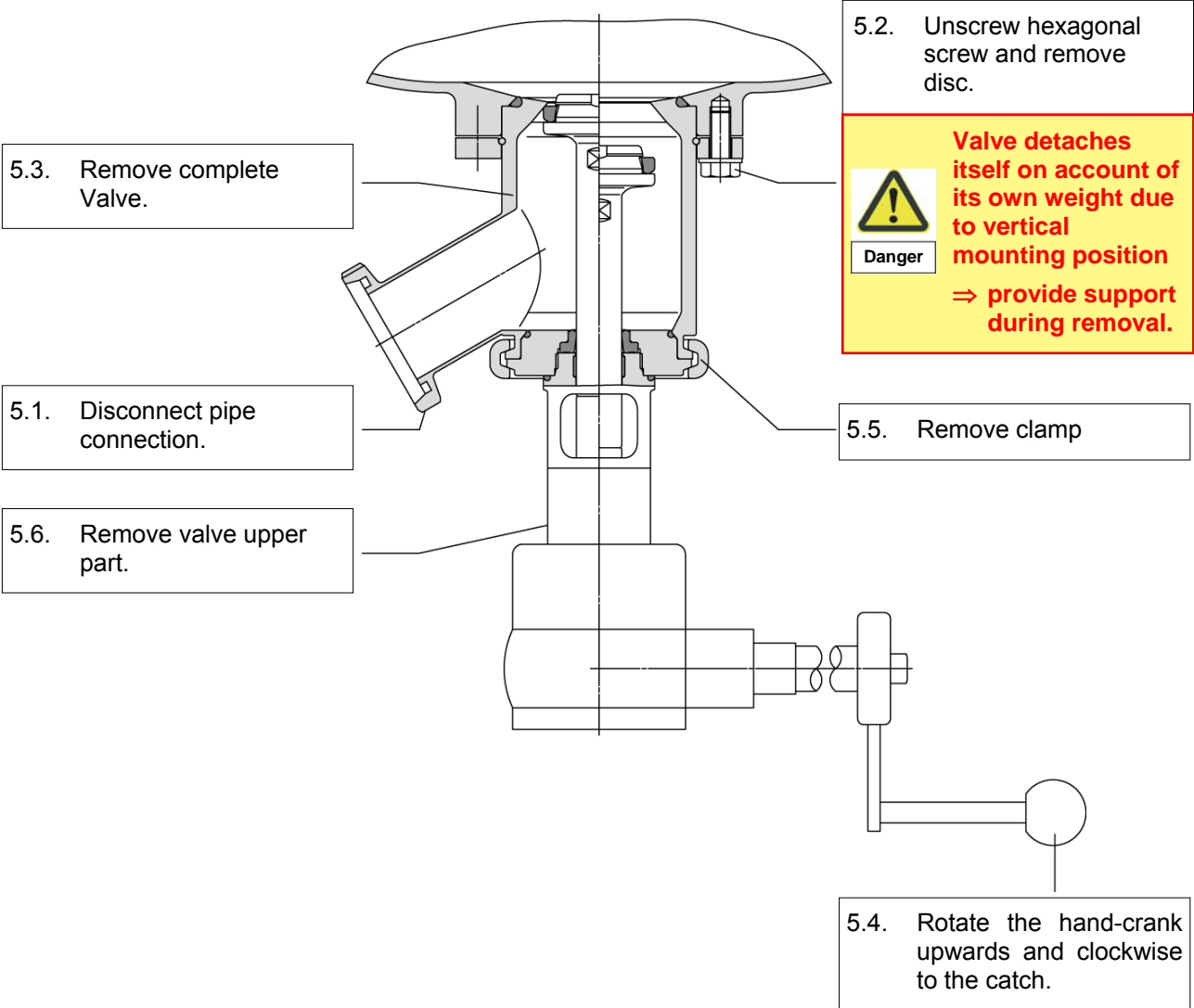

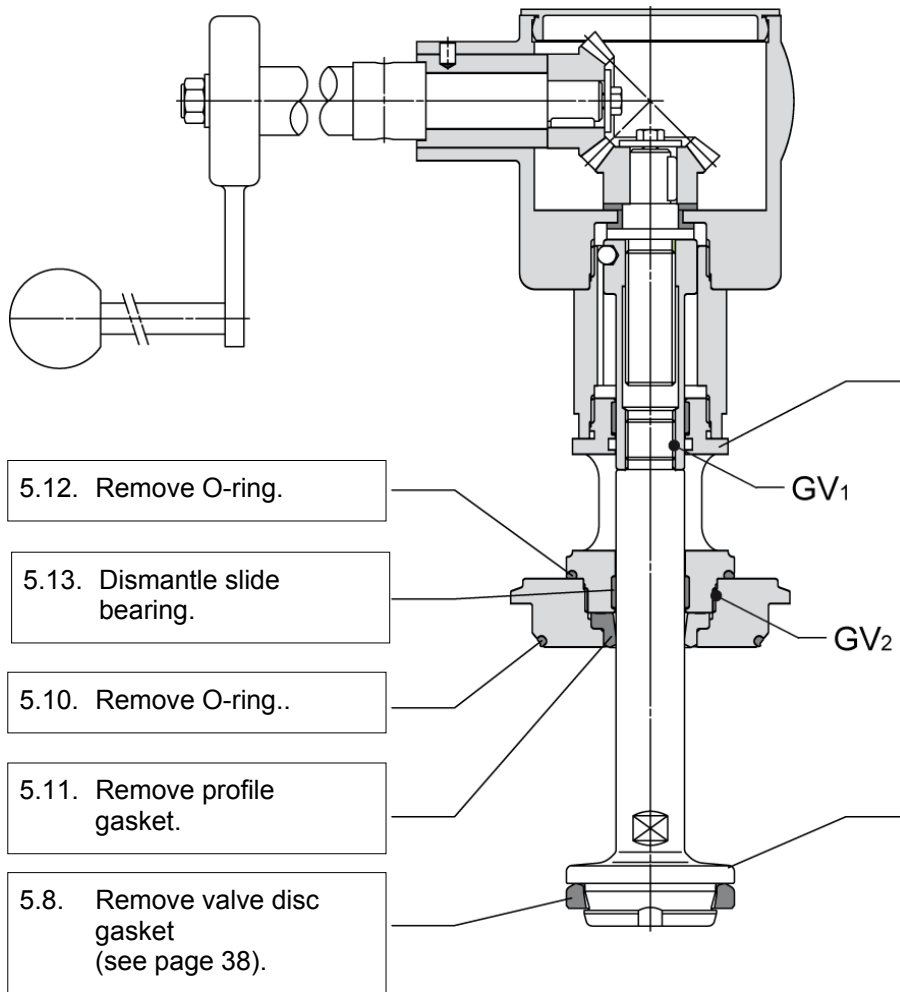

5.12. Remove O-ring.

5.13. Dismantle slide bearing.

5.10. Remove O-ring..

5.11. Remove profile gasket.

5.8. Remove valve disc gasket (see page 38).

5.9. Unscrew bevelled wheel drive by loosen threaded connection GV<sub>2</sub>.  
Mounting tool:  
⇒ hock wrench with finger 45/50

  
**Avoid damages**  
Caution

5.7. Unscrew vale disc.

  
**secure threaded connection GV<sub>1</sub> with glue (order no. 0630210) during assembly.**  
**Mounting tools**  
- forked open jaw wrench SW 17 – 19  
- Piercer ø6

**Pneum. SVPbottom seat valve - Profile gasket – PEEK gasket**

**Disassembly**

In succession 6.1. – 6.15.

Steps 6.5. and 6.7. only required with the drive function air-opened – spring closed.

**Assembly**

In succession 6.15. – 6.1.

Steps 6.5. and 6.7. only required with the drive function air-opened – spring closed.

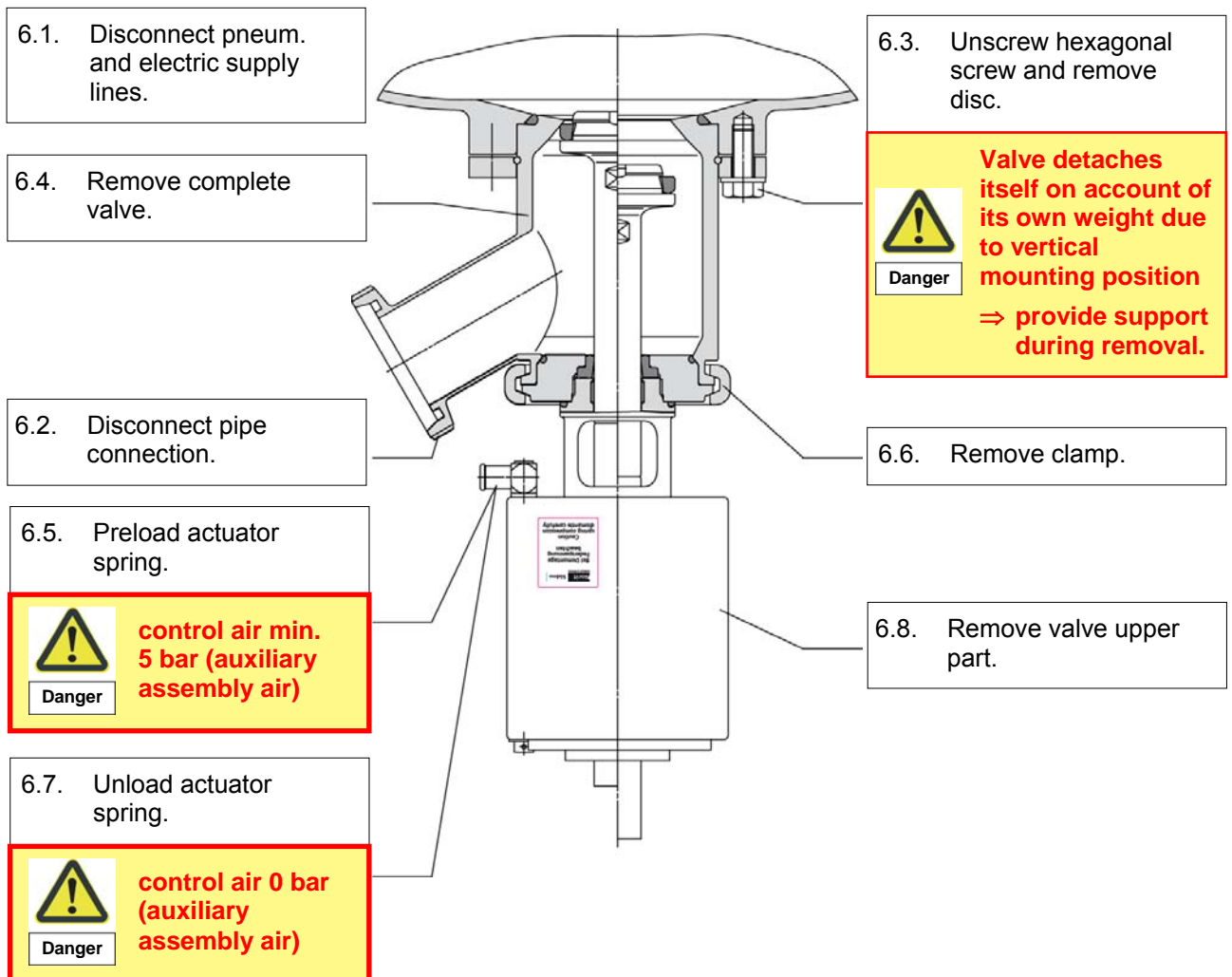

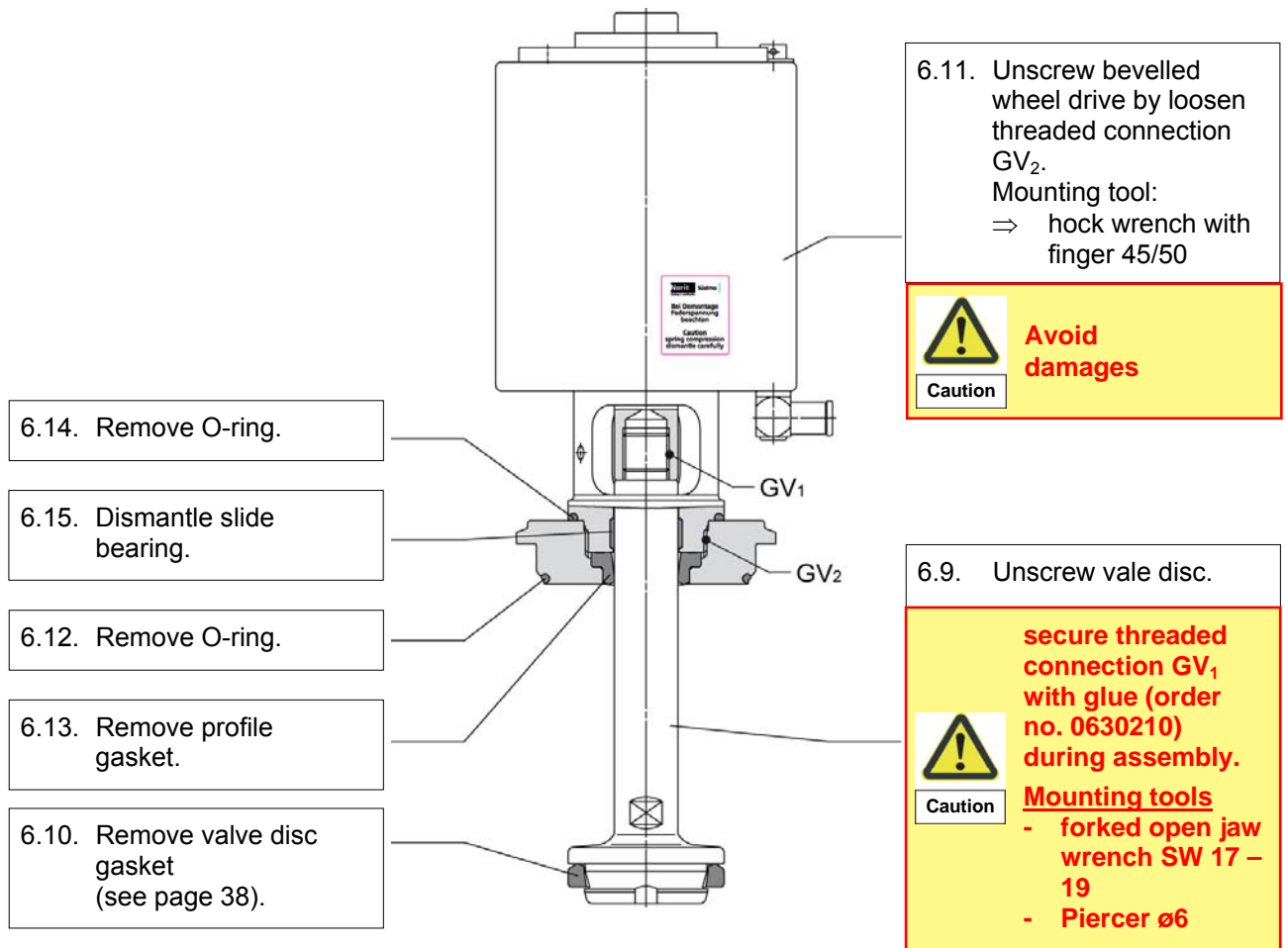

**Assembly instructions - Profile gasket – PEEK gasket**

**Assembly**

Cut the valve disc gasket with the soldering iron (soldering point temperature min. 380°C)



Caution

***In order to avoid personal injuries and damages of the valve disc, please do not cut the valve disc gasket with a knife, a saw or something similar.***

***⇒ Do not damage the sealing groove***

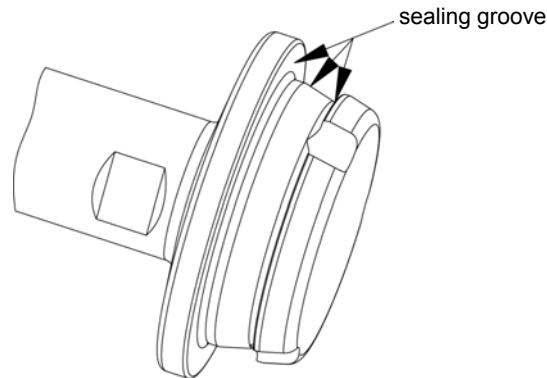

**Installation**

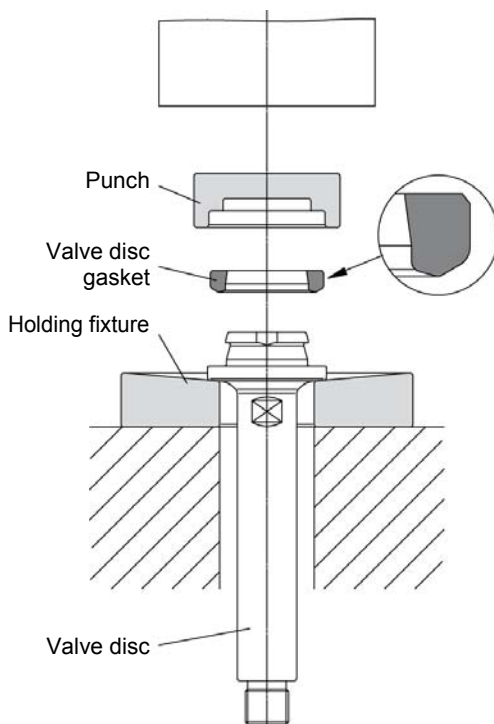

- ⇒ Tools and devices required:
  - lifting devices, press, upright drilling: hydr., pneum. or mech.
  - Punch - Order no. acc. to page 30
  - Holding fixture - Order no. acc. to page 30
- ⇒ Positioning of the holding fixture and the valve disc in the direction of the lifting acc. to the assembly drawing.
- ⇒ Insert valve disc gasket



**Pay attention to the installation position of the valve disc gasket !**

- ⇒ Insert punch on the valve disc gasket

## Operating instructions

SVP bottom seat valve, manually and pneum. operated  
Profile gasket – O-ring, Profile gasket – PEEK gasket  
DN 25 – 100, DN 1" – 4"

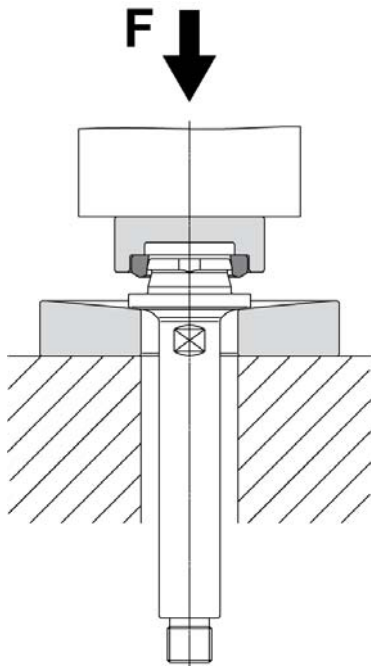

⇒ Attach press in a slow lifting on the punch and put it into the nut. As soon as the gasket is snapped into the nut, stop lifting immediately.



Do not press the gasket against the limit stop.

⇒ If there is a pressure against the limit stop the valve disc gasket can be damaged.



Caution

**For the assembly of the valve disc gasket do NOT use a hammer.**

**Pneum. actuator**

**Operation: air opened – spring closed**

**Disassembly**

In succession 7.1. – 7.12.

**Assembly**

In succession 7.12. – 7.1.

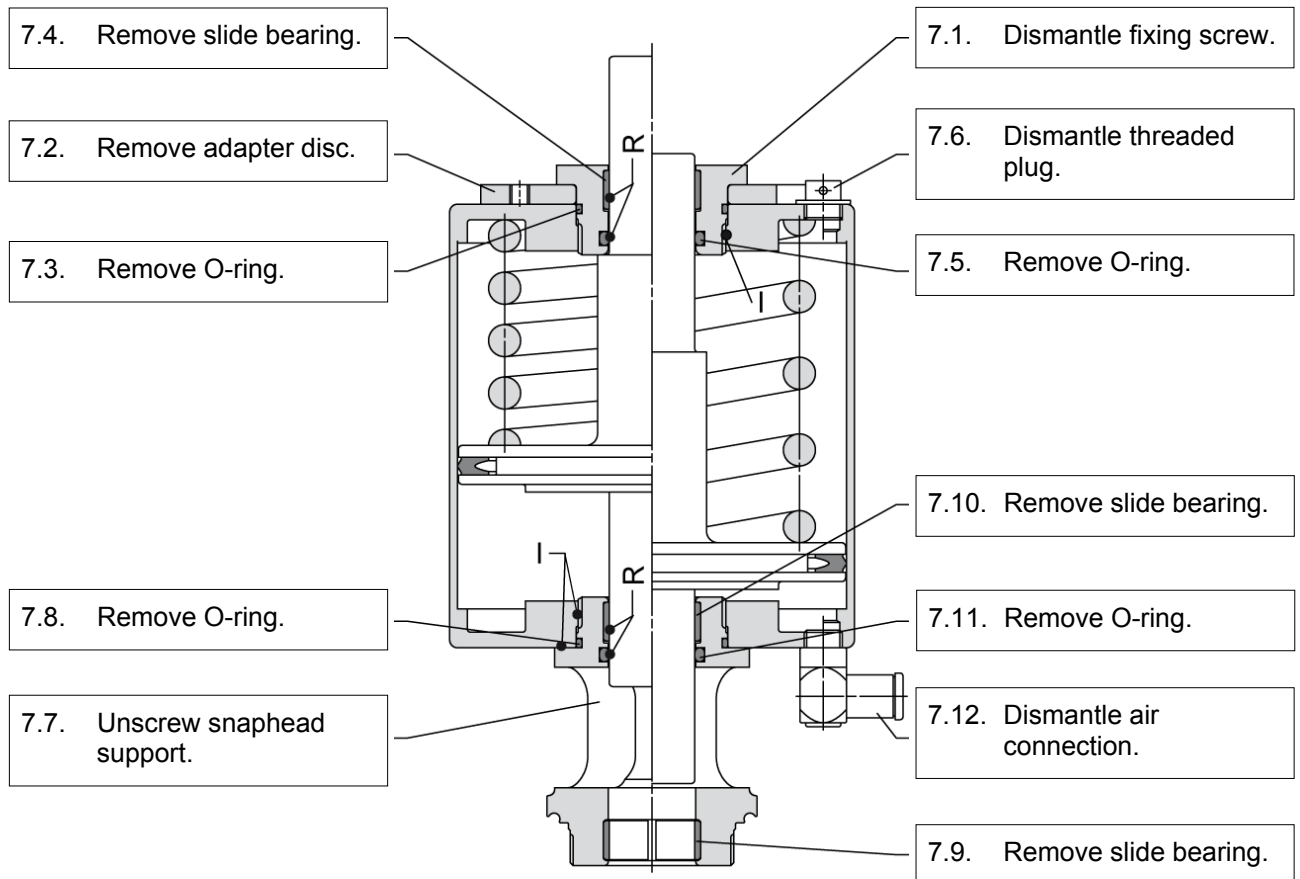

**Grease chart**

- R = Flowing-on RENOLIT SI 410 M with a brush on the marked surfaces
- I = Skim IFB PW 119 with a brush on the marked surfaces

**Pneum. actuator with Booster**

**Mounting the booster subsequently**

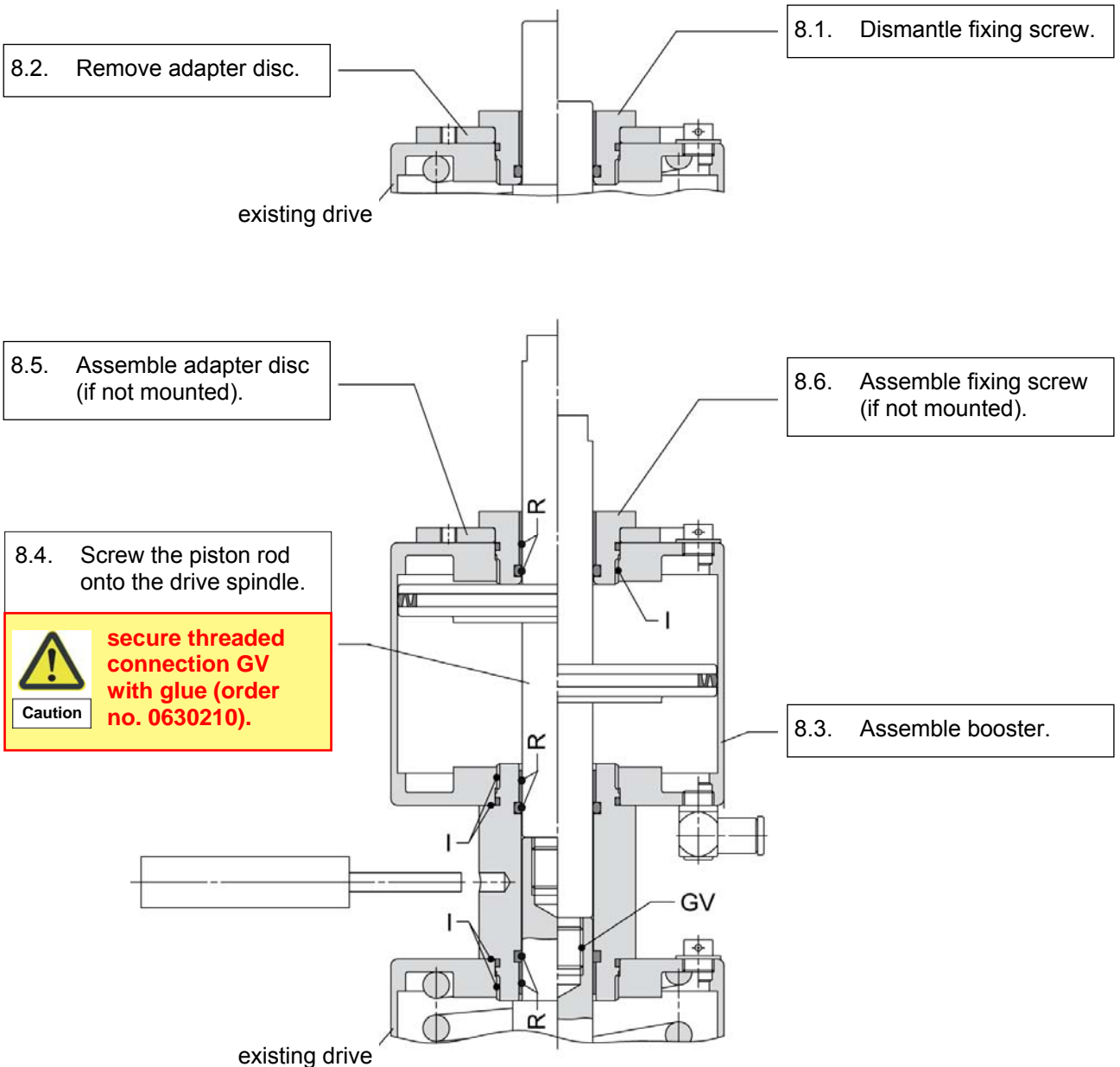

**Grease chart**

- R = Apply RENOLIT SI 410 M with a brush on the marked surfaces
- I = Skim IFB PW 119 with a brush on the marked surfaces

**Demontage**

Reihenfolge 9.1. – 9.16.

**Montage**

Reihenfolge 9.16. – 9.1.

**Assemble slide bearings into adapter**



Caution

Mount slide bearings with slot pins into the adapter. The bearing has to be lowered 2 mm.

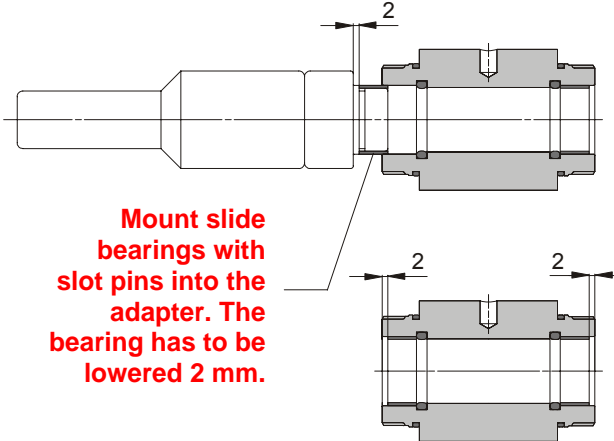

**Grease chart**

- R = Apply RENOLIT SI 410 M with a brush on the marked surfaces
- I = Skim IFB PW 119 with a brush on the marked surfaces

9.6. Dismantle piston rod.



Caution

secure threaded connection GV with glue (order no. 0630210) during assembly.

9.5. Remove slide bearing.

9.3. Remove O-ring.

9.2. Remove adapter disc.

9.9. Dismantle booster.

9.13. Remove O-ring.

9.11. Remove O-ring.

9.14. Remove O-ring.

9.16. Remove O-ring.

9.1. Dismantle fixing screw.

9.7. Dismantle threaded plug.

9.4. Remove O-ring.

9.12. Remove slide bearing.

9.8. Dismantle air connection.

9.10. Dismantle adapter.

9.15. Remove slide bearing.

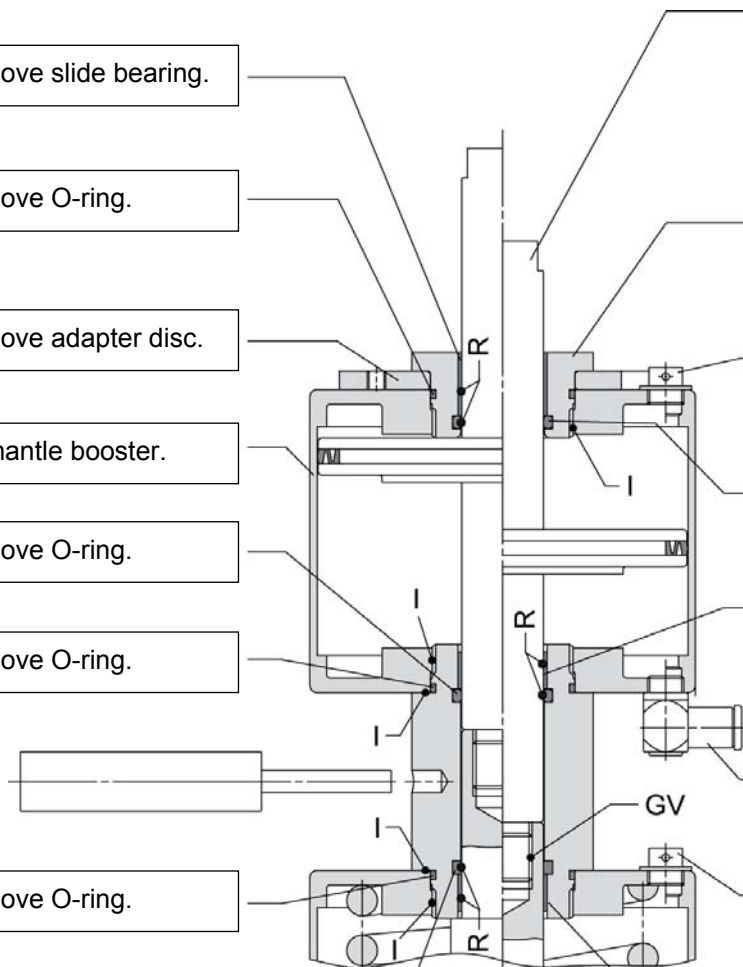

**Montage Prozess-Steuerkopf Typ 1066**

**Fettplan**

R = RENOLIT SI 410 M  
mit Pinsel am Umfang auftragen

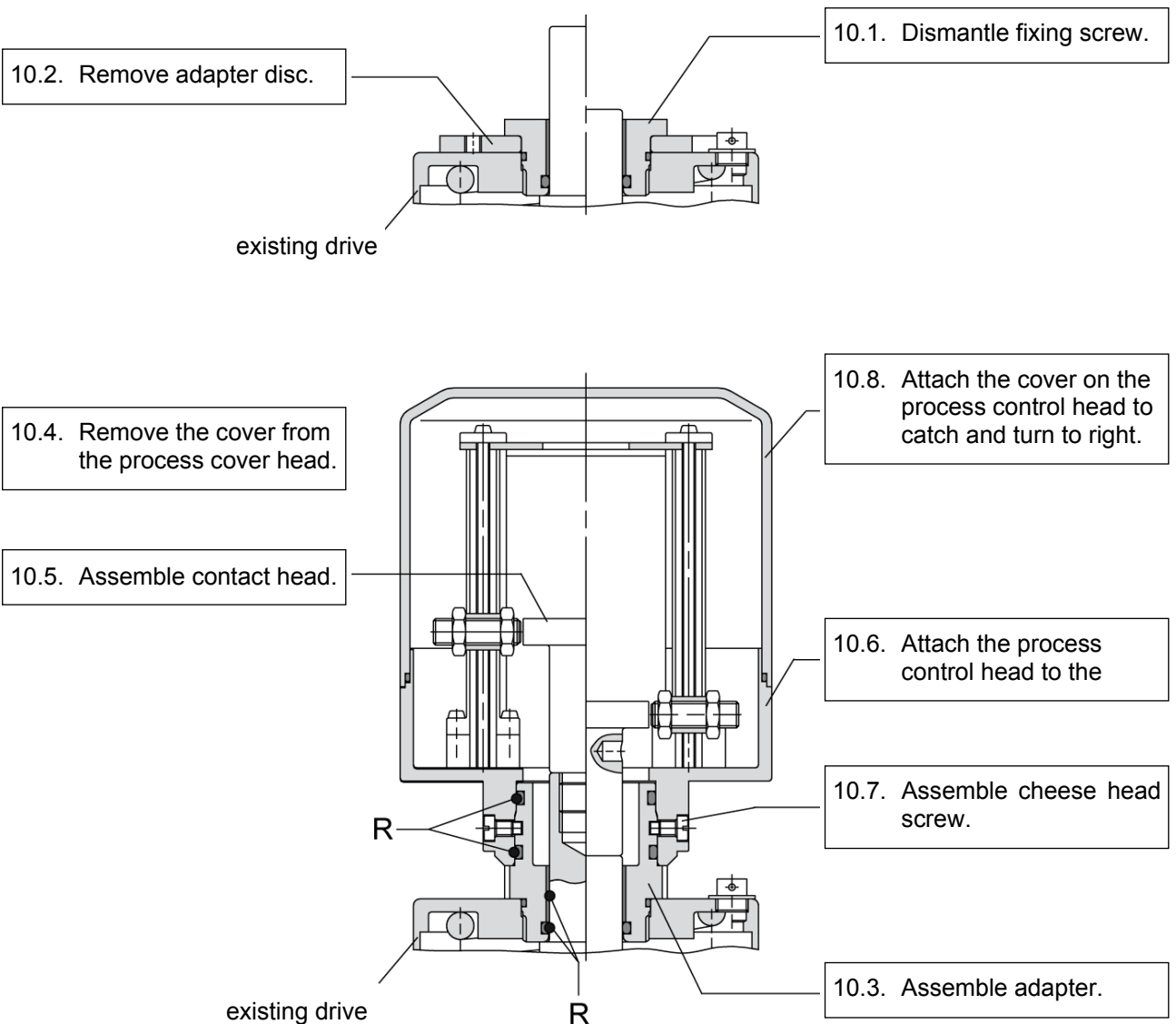

**Montage Prozess-Steuerkopf IntelliTop® Typ 8680**

**Grease chart**

R = Apply RENOLIT SI 410 M with a brush on the marked surfaces

11.2. Remove adapter disc.

11.1. Dismantle fixing screw.

existing drive

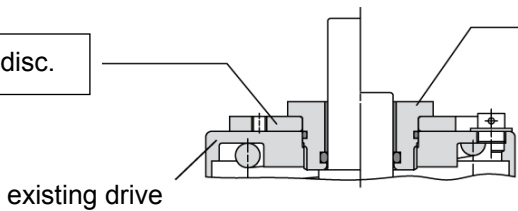

11.5. Attach the process control head to the

11.4. Assemble contact head.

11.6. Assemble cheese head screw.

11.3. Assemble adapter.

existing drive

R

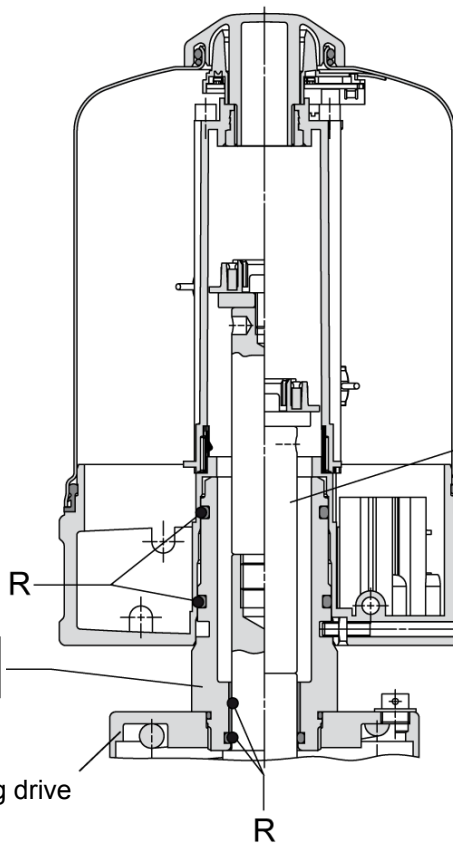

## Start-up



- ⇒ ***Ensure that no foreign objects are present in the piping system.***
- ⇒ ***Avoid temperature shock!  
Component should be heated up carefully till operating temperature is achieved.***

## Functional test

### Manual version

Test valve by actuating the manual drive.  
System must be cleaned before the first product run.

### Pneumatic version

Multiple switching of the valve by means of actuation with compressed air.  
System must be cleaned before the first product run.

## Leak test

Check visually that all seals are free from leaks.  
Defective seals must be replaced.

## Maintenance

### Before maintenance



- ⇒ **Depressurize piping system, drain all liquid and shut off control air supply.**
- ⇒ **Preload closing springs with auxiliary assembly air when removing the actuator of spring-closed valves.**
- ⇒ **if the closing springs are not preloaded when removing the actuator, there might be danger of injury when the clamping joint is loosened because the drive releases spring tension.**
- ⇒ **Pay due regard to the electric supply voltage; switch off the power supply if necessary.**
- ⇒ **Maintenance work must be carried out by qualified and trained personnel only.**

### Inspection

Norit Südmo valves do not special maintenance. Between maintenance intervals, however, the seal tightness and correct operation should be verified by means of a periodic visual inspection.

### Preventive maintenance

Practice-oriented maintenance intervals can only be determined by the respective user/operator as they are dependent on the following application parameters:

- ⇒ Operating frequency
- ⇒ Switching intervals
- ⇒ Type of product
- ⇒ Type of cleaning (CIP / SIP)

We can recommend the following data as guide values:

- ⇒ for liquids with solid particles and temperatures of 80 °C to 100 °C approx. every 3 – 6 months
- ⇒ for liquids with solid particles and temperatures of 60 °C approx. every 12 months
- ⇒ for liquids without solid particles and with temperatures of max. 60 °C approx. every 24 months.

In cleaning systems, intervals of 12 months are recommended.

The intervals stated above are, of course, based on the assumption that the seal materials are sufficiently chemical-resistant.

**Disorder - trouble shooting**



**Danger**

- ⇒ **Never touch the valve or piping system when hot products are in processing or during sterilization.**
- ⇒ **Observe strictly the technical data.**
- ⇒ **We cannot be held liable for an incorrect use of the valve.**



**Caution**

- ⇒ **In the event of disorders immediately deactivate the valve and secure it against inadvertent reactivation.**
- ⇒ **Defects may only be rectified by qualified personnel observing the safety instructions.**

Disorder	Cause	Trouble shooting
Valve does not work	⇒ Error in the control system	⇒ Check the plant configuration
	⇒ no compressed air	⇒ check the air supply
	⇒ air pressure too low	⇒ Check the air hoses for free passage and leaks
	⇒ Error in the electric system	⇒ Check actuation / process control head and routing of electric lines
Discharge of air from the actuator	⇒ Solenoid valve damaged	⇒ Replace the solenoid valve
	⇒ faulty gaskets at the spindle	⇒ change gaskets
	⇒ faulty gasket in the actuator	⇒ change actuator cylinder
Valve does not close	⇒ Dirt / foreign materials in the seal area	⇒ Clean valve housing and seal area closing sleeve and valve disc
Valve closes too slow	⇒ Actuator seals dry (friction losses)	⇒ Grease the seals - Note grease plan
Leakage on the support or stem extension	⇒ defective gaskets	⇒ change gaskets
Valve closes jerkily	⇒ Seals dry (friction losses)	⇒ Grease the seals - Note grease plan
		⇒ Replace seals
Leakage on the weld-in flange	⇒ defective flange gasket	⇒ change gasket



**List of spare parts**

**SVP bottom seat valve - Profile gasket – O-ring**

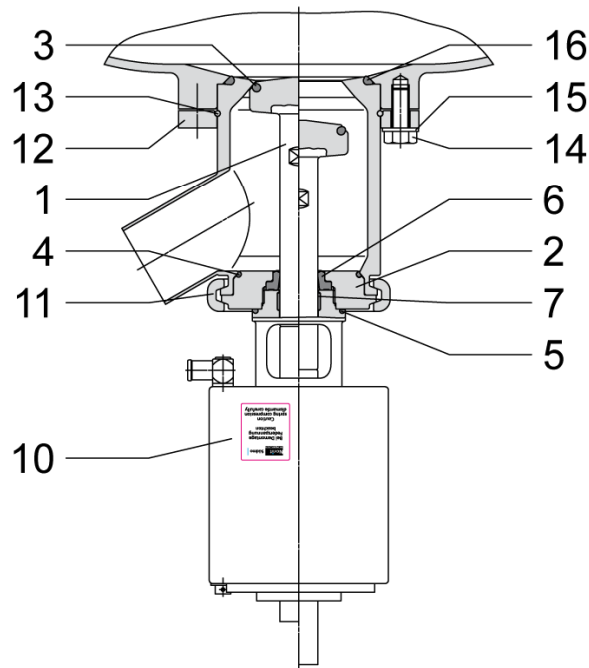
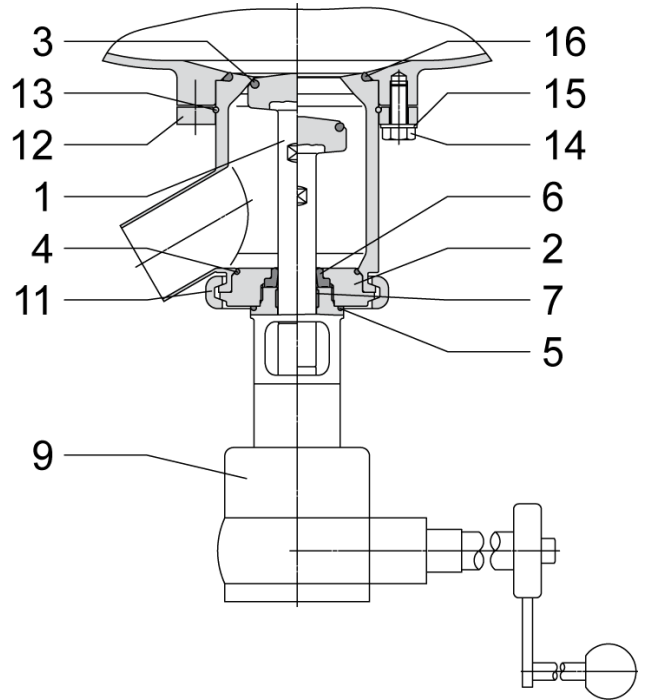
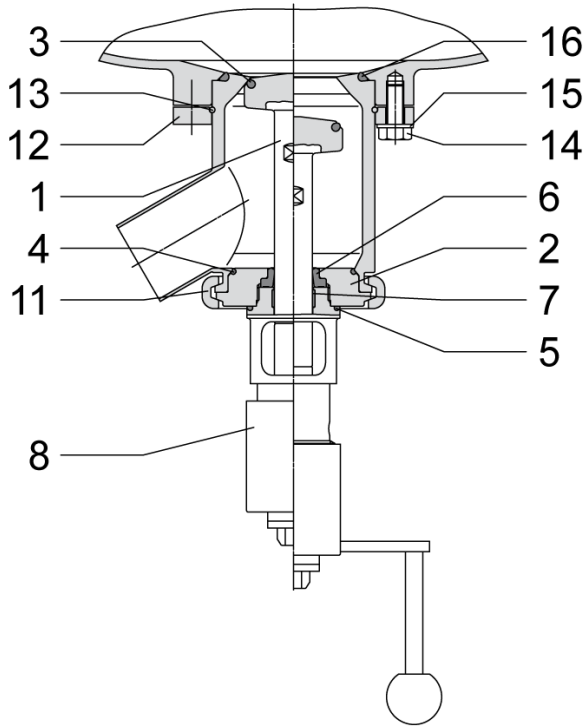

Pos.	Pcs.	Denomination	Material		Order no.		Order no.
1	1	Valve disc	1.4404	DN 25 / DN 1"	2160510	DN 40 / DN 1 1/2"	2154901
2	1	Support	1.4404		2160445		2131965
3	1	O-ring *	EPDM		2912862		2159461
			FPM		2101377		2128515
			HNBR		2130810		2130812
4	1	O-ring *	EPDM		0939355		0939355
			FPM		2128518		2128518
			HNBR		2130829		2130829
5	1	O-ring *	EPDM		0962118		0962118
6	1	Profile gasket *	EPDM		2103016		2103016
			FPM		2128527		2128527
			HNBR		2130749		2130749
7	1	Slide bearing *	PEEK		2131741		2131741
8	1	Manual drive			2155858		2155858
9	1	Bevelled wheel drive					
10	1	Pneum.actuator					
		Air opened – spring closed		2131736	2131736		
		Spring opened – air closed		2155652	2155652		
11	1	Clamp	1.4301	0034447	0034447		
12	1	Loose flange	1.4301	2123265	2123265		
13	1	Snap ring	1.4310	0925115	0925115		
14	4	Hexagonal screw	A 2-70	0075739	0075739		
15	4	Disc	A 2	0165068	0165068		
16	1	O-ring	EPDM	2912892	2912892		
			FPM	2105792	2105792		
			HNBR	2130833	2130833		
	1	Compl. set of gaskets consist. of: *	EPDM	2132024	2132025		
			FPM	2143626	2143627		
			HNBR	2156768	2156741		

Pos.	Pcs.	Denomination	Material		Order no.		Order no.
1	1	Valve disc	1.4404	DN 50 / DN 2"	2154902	DN 65 / DN 2 1/2"	2154903
2	1	Support	1.4404		2131744		2131964
3	1	O-ring *	EPDM		2159462		2912892
			FPM		2128517		2105792
			HNBR		2130823		2130833
4	1	O-ring *	EPDM		0966796		0690719
			FPM		2108787		2117463
			HNBR		2130785		2130839
5	1	O-ring *	EPDM		0962118		0962118
6	1	Profile gasket *	EPDM		2103016		2103016
			FPM		2128527		2128527
			HNBR		2130749		2130749
7	1	Slide bearing *	PEEK		2131741		2131741
8	1	Manual drive			2155858		2155859
9	1	Bevelled wheel drive					
10	1	Pneum.actuator					
		Air opened – spring closed		2131736	2131737		
		Spring opened – air closed		2155652	2155853		
11	1	Clamp	1.4301	0034587	0036590		
12	1	Loose flange	1.4301	2123267	2123269		
13	1	Snap ring	1.4310	2128585	2128586		
14	4	Hexagonal screwe	A 2-70	0075739	0205526		
15	4	Disc	A 2	0165068	0165076		
16	1	O-ring	EPDM	2141486	2100531		
			FPM	2128521	2122715		
			HNBR	2130791	2122854		
	1	Compl. set of gaskets consist. of: *	EPDM	2132026	2132027		
			FPM	2143628	2143629		
			HNBR	2156745	2156748		

Pos.	Pcs.	Denomination	Material		Order no.		Order no.
1	1	Valve disc	1.4404	DN 80 / DN 3"	2154904	DN 100 / DN 4"	2154905
2	1	Support	1.4404		2131745		2131966
3	1	O-ring *	EPDM		2128484		2128485
			FPM		2128523		2128524
			HNBR		2130792		2130796
4	1	O-ring *	EPDM		0770669		0953620
			FPM		2101483		2115337
			HNBR		2130788		2130754
5	1	O-ring *	EPDM		0962118		0962118
6	1	Profile gasket *	EPDM		2103016		2103016
			FPM		2128527		2128527
			HNBR		2130749		2130749
7	1	Slide bearing *	PEEK		2131741		2131741
8	1	Manual drive			2155860		2155860
9	1	Bevelled wheel drive					
10	1	Pneum.actuator					
		Air opened – spring closed		2131738	2132023		
		Spring opened – air closed		2155854	2156074		
11	1	Clamp	1.4301	0034595	2125807		
12	1	Loose flange	1.4301	2123271	2123298		
13	1	Snap ring	1.4310	2128587	2128588		
14	4	Hexagonal screw	A 2-70	0205526	0771378		
15	4	Disc	A 2	0165076	0165076		
16	1	O-ring	EPDM	2109427	2100533		
			FPM	2128525	2128526		
			HNBR	2121365	2122864		
	1	Compl. set of gaskets consist. of: *	EPDM	2132028	2132029		
			FPM	2143630	2143631		
			HNBR	2156738	2156739		

**SVP bottom seat valve - Profile gasket – PEEK gasket**

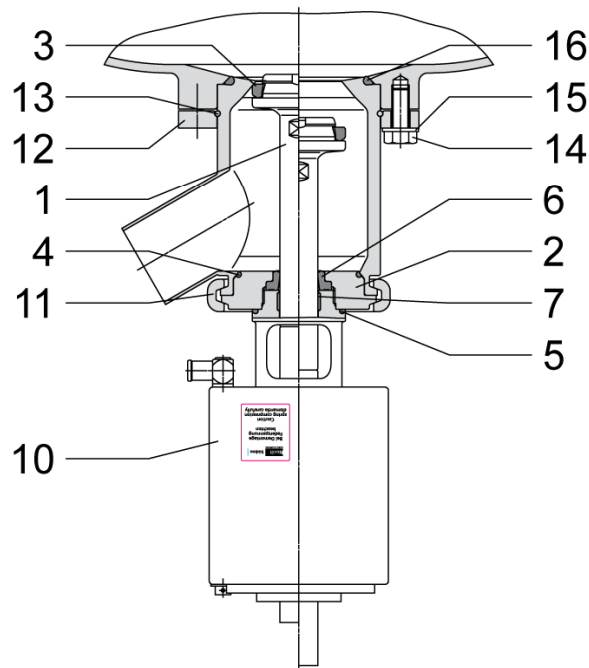
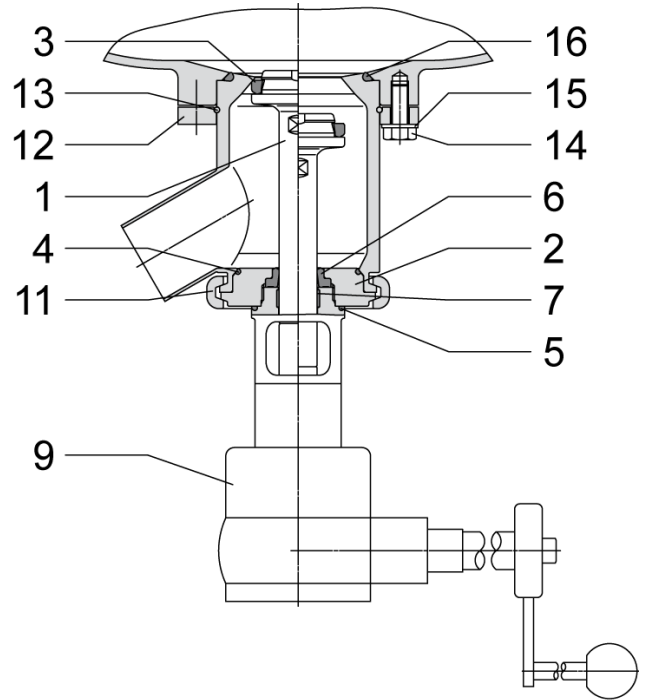
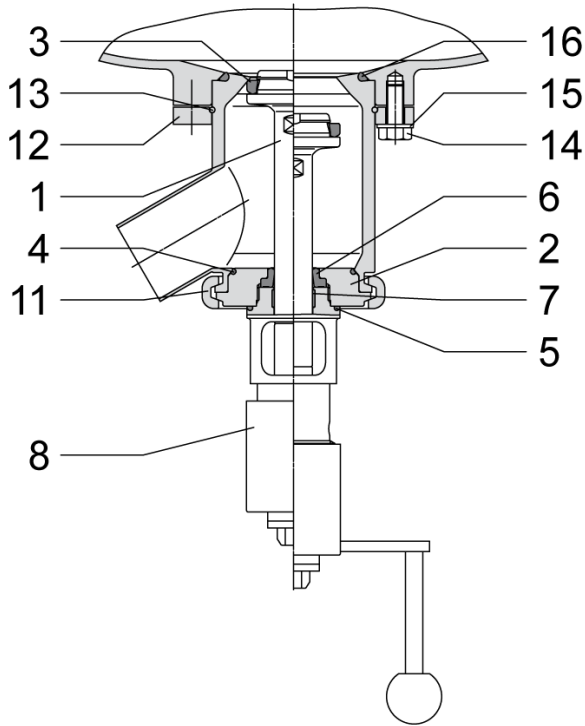

**Operating instructions**

SVP bottom seat valve, manually and pneum. operated  
Profile gasket – O-ring, Profile gasket – PEEK gasket  
DN 25 – 100, DN 1" – 4"

Pos.	Pcs.	Denomination	Material		Order no.		Order no.
1	1	Valve disc	1.4404	DN 25 / DN 1"		DN 40 / DN 1 1/2"	
2	1	Support	1.4404				
3	1	Valve disc gasket *	PEEK				
4	1	O-ring *	EPDM				
			FPM				
			HNBR				
5	1	O-ring *	EPDM				
6	1	Profile gasket *	EPDM				
			FPM				
			HNBR				
7	1	Slide bearing *	PEEK				
8	1	Manual drive					
9	1	Bevelled wheel drive					
10	1	Pneum.actuator					
		Air opened – spring closed					
		Spring opened – air closed					
11	1	Clamp	1.4301				
12	1	Loose flange	1.4301				
13	1	Snap ring	1.4310				
14	4	Hexagonal screw	A 2-70				
15	4	Disc	A 2				
16	1	O-ring	EPDM				
			FPM				
			HNBR				
	1	Compl. set of gaskets consist. of: *	EPDM				
			FPM				
			HNBR				

Pos.	Pcs.	Denomination	Material		Order no.		Order no.
1	1	Valve disc	1.4404	DN 50 / DN 2"		DN 65 / DN 2 1/2"	
2	1	Support	1.4404				
3	1	Valve disc gasket *	PEEK				
4	1	O-ring *	EPDM				
			FPM				
			HNBR				
5	1	O-ring *	EPDM				
6	1	Profile gasket *	EPDM				
			FPM				
			HNBR				
7	1	Slide bearing *	PEEK				
8	1	Manual drive					
9	1	Bevelled wheel drive					
10	1	Pneum.actuator					
		Air opened – spring closed					
		Spring opened – air closed					
11	1	Clamp	1.4301				
12	1	Loose flange	1.4301				
13	1	Snap ring	1.4310				
14	4	Hexagonal screw	A 2-70				
15	4	Disc	A 2				
16	1	O-ring	EPDM				
			FPM				
			HNBR				
	1	Compl. set of gaskets consist. of: *	EPDM				
			FPM				
			HNBR				

## Operating instructions

SVP bottom seat valve, manually and pneum. operated  
Profile gasket – O-ring, Profile gasket – PEEK gasket  
DN 25 – 100, DN 1" – 4"

Pos.	Pcs.	Denomination	Material		Order no.		Order no.
1	1	Valve disc	1.4404	DN 80 / DN 3"		DN 100 / DN 4"	
2	1	Support	1.4404				
3	1	Valve disc gasket *	PEEK				
4	1	O-ring *	EPDM				
			FPM				
			HNBR				
5	1	O-ring *	EPDM				
6	1	Profile gasket *	EPDM				
			FPM				
			HNBR				
7	1	Slide bearing *	PEEK				
8	1	Manual drive					
9	1	Bevelled wheel drive					
10	1	Pneum.actuator					
		Air opened – spring closed					
		Spring opened – air closed					
11	1	Clamp	1.4301				
12	1	Loose flange	1.4301				
13	1	Snap ring	1.4310				
14	4	Hexagonal screw	A 2-70				
15	4	Disc	A 2				
16	1	O-ring	EPDM				
			FPM				
			HNBR				
	1	Compl. set of gaskets consist. of: *	EPDM				
			FPM				
			HNBR				

**Pneum. actuator**

**Operation: air opened – spring closed**

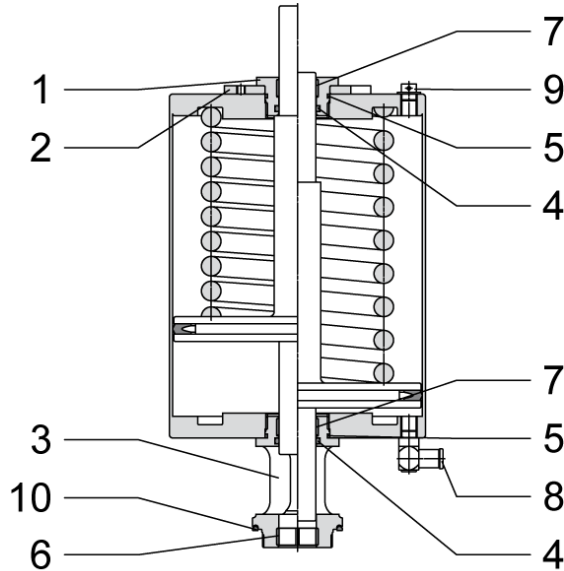

Pos.	Pcs.	Denomination	Material		Order no.		Order no.
	1	Pneum. actuator			2131736		2131737
1	1	Fixing screw	1.4305	DN 25 - 50 / DN 1" - 2"	2131739	DN 65 / DN 2 1/2"	2131739
2	1	Adapter disc	1.4301		2128219		2128219
3	1	Snaphead support	1.4301		2131734		2131734
4	1	O-ring *	NBR		0116723		0116723
5	1	O-ring *	NBR		2128764		2128764
6	1	Slide bearing *	PEEK		2131741		213741
7	1	Slide bearing *	Iglidur		2131740		2131740
8	1	Angular screw-in-union			2116513		2116513
9	1	Threaded plug			2128550		2128550
10	1	O-ring *	EPDM		0962118		0962118
	1	Compl. set of gaskets consist. of: *			2132039		2132039

**Operating instructions**

SVP bottom seat valve, manually and pneum. operated  
Profile gasket – O-ring, Profile gasket – PEEK gasket  
DN 25 – 100, DN 1" – 4"

Pos.	Pcs.	Denomination	Material		Order no.		Order no.
		Pneum. actuator		DN 80 / DN 3"	2131738	DN 100 / DN 4"	2132023
1	1	Fixing screw	1.4305		2131739		2131739
2	1	Adapter disc	1.4301		2128219		2128219
3	1	Snaphead support	1.4301		2131735		2131735
4	1	O-ring *	NBR		0116723		0116723
5	1	O-ring *	NBR		2128764		2128764
6	1	Slide bearing *	PEEK		2131741		2131741
7	1	Slide bearing *	Iglidur		2131740		2131740
8	1	Angular screw-in-union			2116513		2116513
9	1	Threaded plug			2128550		2128550
10	1	O-ring *	EPDM		0962118		0962118
	1	Compl. set of gaskets consist. of: *		2132039	2132039		

**Booster**

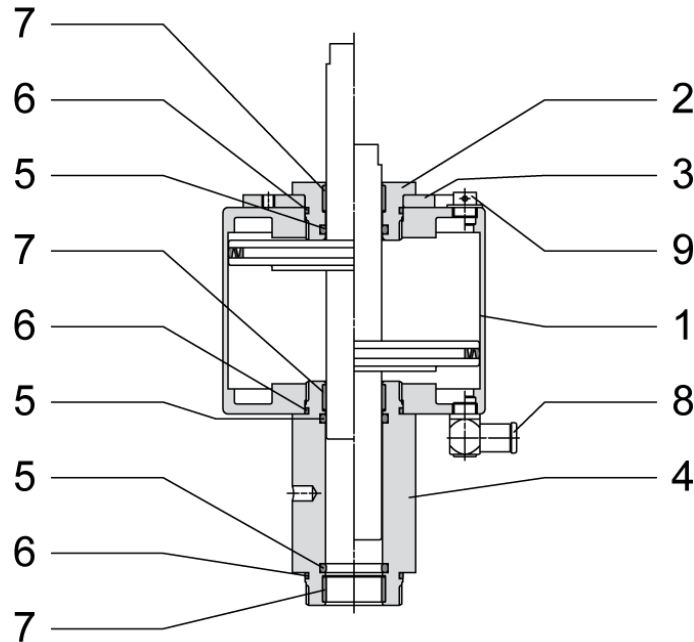

Pos.	Pcs.	Denomination	Material	Order no.	Order no.	Order no.
	1	Booster			2154327	
1	1	Cylinder			2128572	
2	1	Fixing screw	1.4301		2131739	
3	1	Adapter disc	1.4301		2128219	
4	1	Adapter	1.4301		2154326	
5	3	O-ring	* NBR		0116723	
6	3	O-ring	* NBR		2128764	
7	3	Slide bearing	* Iglidur		2131740	
8	1	Angular screw-in-union			2116513	
9	1	Threaded plug	PP		2128550	
	1	Compl. set of gaskets consist. of:	*			

**EC Declaration of Incorporation**

The manufacturer,

**Südmo Components GmbH**  
**Industriestraße 7**  
**D-73469 Riesbürg-Pflaumloch**

hereby declares that the:

**SVP bottom seat valve**

**Type:** S385 Select  
**Catalogue no.:** S385 Select – S387 Select  
**Year of manufacture:** 2010

comply with the following basic requirements of the **Machinery Directive (2006/42/EC)**.  
Appendix I, Articles 1.1.2, 1.1.3, 1.1.5, 1.3.2, 1.3.4, 1.5.3, 1.5.4, 1.5.5, 1.5.13, 1.6, 1.7.1, 1.7.2, 1.7.3, 1.7.4  
and 2.1.

The partly completed machine / system component furthermore complies with all regulations of the directives  
**Electrical equipment (2006/95/EC)** and **Electromagnetic compatibility (2004/108/EC)**.

**Applied harmonized standards**

- ⇒ DIN EN 12100-1 Safety of machinery – Basic terms, general principles for design - Part 1: Basic terminology, methods
- ⇒ DIN EN 12100-2 Safety of machinery – Basic terms, general principles for design, part 2: Technical principles and specifications
- ⇒ DIN EN 60204-1 Safety of machinery - Electrical equipment of machines, Part 1: General requirements
- ⇒ DIN EN 1672-2 Food processing machinery – Basic concepts – Part 2: Hygiene requirements

Do not put the partly complete machine / system component into operation unless it has been verified that the machine/system the partly complete machine/system component is to be built into complies with the regulations of the machinery directive (2006/42/EC).

TD authorized person

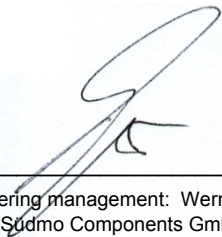
  
Engineering management: Werner Deger,  
Südmo Components GmbH  
Industriestraße 7, D-73469 Riesbürg

Riesbürg, 25.02.2010

  
Managing Director  
Oliver Rupp

## Declaration of Conformity

according to Appendix VII of the pressure equipment directive "Directive 97/23/EC"

The manufacturer,

**Südmo Components GmbH**  
**Industriestraße 7**  
**D-73469 Riesbürg-Pflaumloch**

hereby declares in sole responsibility that the product

### SVP bottom seat valve

**Type:**                    **S285 Select**  
                                 **S385 Select**

**Catalogue no.:**        **S285Select – S288 Select**  
                                 **S385 Select – S387 Select**

to which this declaration refers complies with the pressure equipment directive "Directive 97/23/EC" and has been submitted to the following conformity process:

### Module A .

#### Applied harmonized European standards

- ⇒ DIN EN 10088-1
- ⇒ DIN EN 10088-2
- ⇒ DIN EN 10088-3
- ⇒ DIN EN 287-1
- ⇒ DIN EN 287-2

#### Other applied standards and technical specifications

- ⇒ AD-2000 regulations
- ⇒ DIN EN 12266-1

#### Additions to the Declaration of Conformity

- ⇒ The nominal diameters DN 125 and larger are not suitable for "Group 1 fluids – hazardous" according to the definition in the pressure equipment directive 97/23/EC especially "Fluid property according to article 9"  
The already mentioned hazardous products are also defined by the pressure equipment directive 97/23/EC especially within the database for hazardous substances.
- ⇒ The nominal diameters DN 25 and smaller are defined according to the definition in the pressure equipment directive 97/23/EC" according to Article 3 Paragraph 3 good engineering practice and **must not be marked** with the CE mark.
- ⇒ Valve manifolds:  
The pressure test on the complete valve manifold cannot be carried out in the factory for manufacturing reasons. This test must be carried out when commissioning the complete system at the customer's. The individual valves have been tested by the manufacturer.

Riesbürg, 25.02.2010



Managing Director  
Oliver Rupp

**EC manufacturer's declaration for the use in explosion area**

The manufacturer,

**Südmo Components GmbH**  
**Industriestraße 7**  
**D-73469 Riesbürg-Pflaumloch**

hereby declares in sole responsibility that the product

**SVP bottom seat valves**

**Type:**                    **S285 Select**  
                                 **S385 Select**

**Catalogue no.:**        **S285Select – S288 Select**  
                                 **S385 Select – S387 Select**

when used according to its designated use does not show any potential risk of ignition as defined by the EC directive 94/9/EC Article 1 and thus does not fall within EC directive 94/9/EC.

This is only valid for valves with the following seal version:  
O-ring

**Information regarding its designated use**

- Underground use must be excluded.
- An equipotential bonding of the complete system must be ensured.
- The maximum surface temperature of the fitting depends on the temperature of the substance to be transported, but, due to friction, pneumatically operated fittings will reach up to +80°C at an outside temperature of +40°C. This limits the substances that can be transported through the fitting as a result of their ignition and glowing temperatures.
- The fitting must not be used in zone Zone 0 for fluids of explosion group IIC (according to DIN EN 50014).
  - The surface area of non-conducting components is < 80 cm<sup>2</sup>
  - All non-conducting components are surrounded by a conducting frame.

**Classification of the hazardous area**

- We point out that the classification in group, category, zone, protection class and temperature class and the definition of any special operating conditions have to be specified by the system manufacturer.
- Please note that leaks in a sealing element may result in the fluid escaping from the valve interior to the atmosphere.

**Applied harmonized European directives and standards and other regulations:**

- ⇒ EN 1127-1
- ⇒ EN 13463-1
- ⇒ DIN EN 50014

**Other applied standards and technical specifications:**

- ⇒ EC Directive 94/9/EC
- ⇒ BGR 132

***Components not included in the operating instructions are excluded from the manufacturer's declaration. Information must be ordered separately.***

Riesbürg, 25.02.2010

  
\_\_\_\_\_  
Managing Director  
Oliver Rupp

## Operating instructions

SVP bottom seat valve, manually and pneum. operated  
Profile gasket – O-ring, Profile gasket – PEEK gasket  
DN 25 – 100, DN 1" – 4"

---

**Service adress**

Südmo Components GmbH

*Industriestraße 7  
D-73469 Riesbürg - Germany*

*T +49 9081 803-0*

*F +49 9081 803-158*

*E info@suedmo.de*

*I www.suedmo.de*

© 2010 Südmo Components GmbH

Subject to technical changes without notice

**Copy of original operating instructions**