

# BAA A370P<sup>3</sup>.03 Select

## SVP aseptic diaphragm valve

### DN 10 – 20

Diaphragm – O-ring, Diaphragm – PEEK  
Pneumatically operated

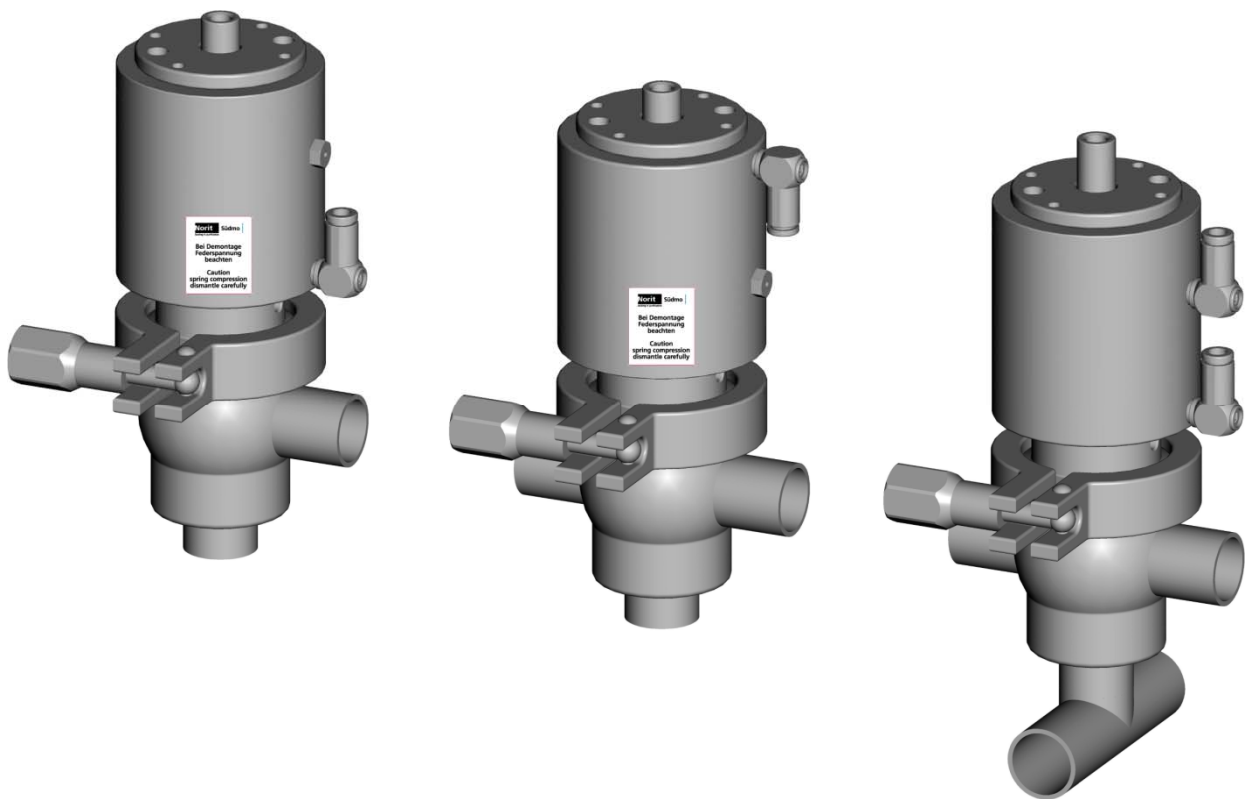

Amendment	Date	Name	Amendment	Date	Name	Amendment	Date	Name	Amendment	Date	Name

created. on/by 25.01.2010 Graf  
checked. on/by 25.01.2010 Deger W.



## 1. Contents

<b>1. Contents</b> .....	<b>2</b>
<b>2. Safety instructions</b> .....	<b>4</b>
2.1. General information .....	4
2.2. Maintenance and service work .....	4
2.3. Modifications to the SVP aseptic diaphragm valve .....	5
2.4. SVP aseptic diaphragm valve with feedback .....	5
2.5. Storage .....	5
2.6. Operation .....	6
2.7. Spare parts .....	6
<b>3. Technical Data</b> .....	<b>7</b>
3.1. Dimensions .....	7
3.1.1. Pneumatic SVP aseptic diaphragm valve .....	7
3.2. Valve insert .....	7
3.3. Material data .....	8
3.4. CIP cleaning .....	8
3.5. Surfaces .....	9
3.6. Pneum. control unit .....	9
3.6.1. Air to open - spring to close .....	9
3.6.2. Spring to open – air to close .....	9
3.6.3. Air to open - air to close .....	9
3.7. Feedback systems .....	10
3.8. Electrical and pneumatic connections .....	10
3.9. Control air .....	11
<b>4. Valve function</b> .....	<b>11</b>
4.1. SVP aseptic diaphragm valve, air to open - spring to close .....	11
4.2. SVP aseptic diaphragm valve spring to open – air to close .....	12
4.3. SVP aseptic diaphragm valve air to open – air to close .....	12
<b>5. Valve connection piping</b> .....	<b>13</b>
5.1. Installation position .....	13
5.2. Valve connections .....	13
5.3. Installation instructions .....	13
<b>6. Installation instructions</b> .....	<b>13</b>
6.1. General notes .....	13
6.2. State on delivery .....	14
6.3. Installation instructions .....	14
6.3.1. Installation space .....	14
6.3.2. Installation .....	14
6.4. Welding instructions .....	14
6.4.1. Field of application .....	14
6.4.2. Welding process .....	14
6.4.3. Type of seam .....	14
6.5. Weld seam preparation .....	14
6.6. Welding .....	14
6.7. Weld filler .....	14

6.8.	Weld seam finishing .....	14
6.8.1.	Interior .....	14
6.8.2.	Exterior .....	15
6.9.	Cleaning .....	15
6.10.	Assembly .....	15
<b>7.</b>	<b>Disassembly – Assembly .....</b>	<b>15</b>
7.1.	Prior to disassembly .....	15
7.2.	SVP aseptic diaphragm valve with feedback .....	16
7.3.	Spare parts .....	16
7.4.	Assembly tools .....	16
7.5.	Replacement of the seals in contact with the product .....	17
7.5.1.	Pneumatic SVP aseptic diaphragm valve, air to open - spring to close .....	17
7.5.2.	Pneumatic SVP aseptic diaphragm valve, spring to open - air to close - Diaphragm - O-ring .....	19
7.5.3.	Pneumatic SVP aseptic diaphragm valve, air to open - air to close - Diaphragm - O-ring .....	21
7.5.4.	Pneumatic SVP aseptic diaphragm valve, air to open - spring to close - Diaphragm – PEEK .....	23
7.5.5.	Pneumatic SVP aseptic diaphragm valve, spring to open - air to close - Diaphragm – PEEK .....	25
7.5.6.	Pneumatic SVP aseptic diaphragm valve, air to open - air to close - Diaphragm – PEEK .....	27
7.6.	Assembling the O-ring .....	28
7.6.1.	Disassembly .....	28
7.6.2.	Installation .....	28
7.7.	Pneum. control unit .....	29
7.7.1.	Operating mode air to open - spring to close .....	29
7.7.2.	Operating mode spring to open - air to close .....	30
7.7.3.	Mode of operation air to open - air to close .....	31
7.8.	Installation of the process control unit IntelliTop® Type 8680 .....	32
<b>8.</b>	<b>Start-up .....</b>	<b>33</b>
8.1.	Functional test .....	33
8.1.1.	Pneumatic design .....	33
8.2.	Leak test .....	33
<b>9.</b>	<b>Maintenance .....</b>	<b>33</b>
9.1.	Before maintenance .....	33
9.2.	Inspection .....	33
9.3.	Maintenance .....	33
<b>10.</b>	<b>Malfunctions - Troubleshooting .....</b>	<b>34</b>
<b>11.</b>	<b>Disposal .....</b>	<b>35</b>
11.1.	Before disposal .....	35
11.2.	Components of the SVP aseptic diaphragm valve .....	35
11.3.	Disposal of the SVP aseptic diaphragm valve .....	35
<b>12.</b>	<b>Spare parts list .....</b>	<b>36</b>
12.1.	SVP aseptic diaphragm valve - Diaphragm - O-ring .....	36
12.2.	SVP aseptic diaphragm valve - Diaphragm – PEEK .....	37
12.3.	Pneum. control unit .....	38
12.3.1.	Mode of operation air to open– spring to close, spring to open– air to close .....	38
12.3.2.	Mode of operation air to open - air to close .....	38
<b>13.</b>	<b>EC Manufacturer's Declaration .....</b>	<b>39</b>
<b>14.</b>	<b>CE marking .....</b>	<b>39</b>
<b>15.</b>	<b>Service address .....</b>	<b>40</b>

## 2. Safety instructions



*This symbol denotes an **imminent danger** to life and health of persons!  
Non-observance of these instructions leads to health risks or life-threatening injuries.*



*This symbol denotes a **potentially imminent danger!**  
Non-observance of these instructions can lead to light injuries or damage to material property.*



**This symbol gives important information on the proper handling of the SVP aseptic diaphragm valve, which must be strictly observed.**  
**Non-observance of these instructions can result in malfunction of the valve or in its environment.**

### 2.1. General information

- ⇒ The SVP aseptic diaphragm valves by Südmo Components GmbH have been manufactured in accordance with state-of-the-art standards and the recognized safety rules. However, these SVP aseptic diaphragm valves may constitute a hazard if used improperly by operating personnel or for a purpose other than the designated one. This may result in a risk to life and limb of the user or of third parties, or cause damage to the SVP aseptic diaphragm valve and other material property.
- ⇒ Anyone who has been designated by the purchaser to install, start up, operate and maintain these SVP aseptic diaphragm valves must have read and understood the complete operating instructions (especially all stipulated safety instructions).
- ⇒ In addition to these operating instructions the following applies as a matter of course:
  - relevant accident prevention regulations
  - generally accepted safety rules
  - national regulations in the country of use
  - company-internal instructions concerning work and safety.

### 2.2. Maintenance and service work

- ⇒ Any maintenance and service work on the SVP aseptic diaphragm valves must be carried out by specially trained and qualified personnel only.  
Qualified personnel as defined by these operating instructions are persons who are familiar with installation, start-up and operation of this product and who have the necessary qualification for their work, including
  - Training or instruction on service and use of the appropriate safety equipment in accordance with the current safety standards
  - First aid training
  - For systems with explosion protection:  
training or instruction or authorization to carry out work on systems subject to explosion hazards (observe ATEX regulations).
- ⇒ Prior to carrying out any maintenance and service work, the following must be ensured and observed:
  - Draining of the pipeline
  - Carry out this work only in depressurized condition and with the media supply shut off
  - Get information on possible risks which could be caused by residues of operating material and take the appropriate measures, if necessary (safety gloves, safety goggles etc.)
  - Allow the fittings to cool down if necessary.
  - Secure the system from unintended start-up by a third person.
  - Ensure compensation of pressure which may occur in shut pipelines.
  - Carry out installation according to the assembly instructions.

- If the closing spring is not pre-tensioned when disassembling the control unit, there is a risk of injury when the clamping joint is released because the spring tension of the actuator is released (refer to label – Diagram A)
- Disconnect the power supply.
- Remove the SVP aseptic diaphragm valve from the piping section, if possible.



Diagram A

- ⇒ Avoid any working method impairing safety and function of the SVP aseptic diaphragm valve.

### 2.3. Modifications to the SVP aseptic diaphragm valve

- ⇒ The user is obliged to operate the SVP aseptic diaphragm valve according to the designated use and safety instructions, being aware of potential dangers. Any changes on the SVP aseptic diaphragm valve, which impair its function and safety, must be reported immediately. The user is obliged to operate the SVP aseptic diaphragm valve only in perfect condition.



Danger

**Modifications to the SVP aseptic diaphragm valve are strictly forbidden**

### 2.4. SVP aseptic diaphragm valve with feedback

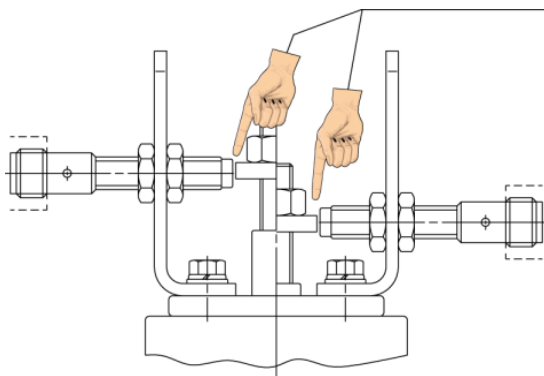

Danger

**Do not reach into the feedback unit.**

⇒ **Risk of accident.**

**Risk of limbs being crushed or cut off.**

### 2.5. Storage

- ⇒ Store the valve dry and protected against external influences.
- ⇒ Prior to handling (disassembly of the body / activation of the actuators) store the valves temporarily in a dry condition for at least 24 hours at a temperature  $\geq 5^\circ \text{C}$ .

## 2.6. Operation



Danger

- ⇒ **Never touch the valve or the pipelines if hot media are processed or if the sterilizing process is running.**
- ⇒ **Always adhere to the technical data.**
- ⇒ **We cannot be held liable for improper operation of the valve.**

## 2.7. Spare parts



Caution

- Use original Norit Südmo spare parts only**
- ⇒ **For Norit Südmo spare parts, refer to the enclosed spare parts list**
- ⇒ **If other spare parts are used**
  - **Exclusion of liability**

### 3. Technical Data

#### 3.1. Dimensions

##### 3.1.1. Pneumatic SVP aseptic diaphragm valve

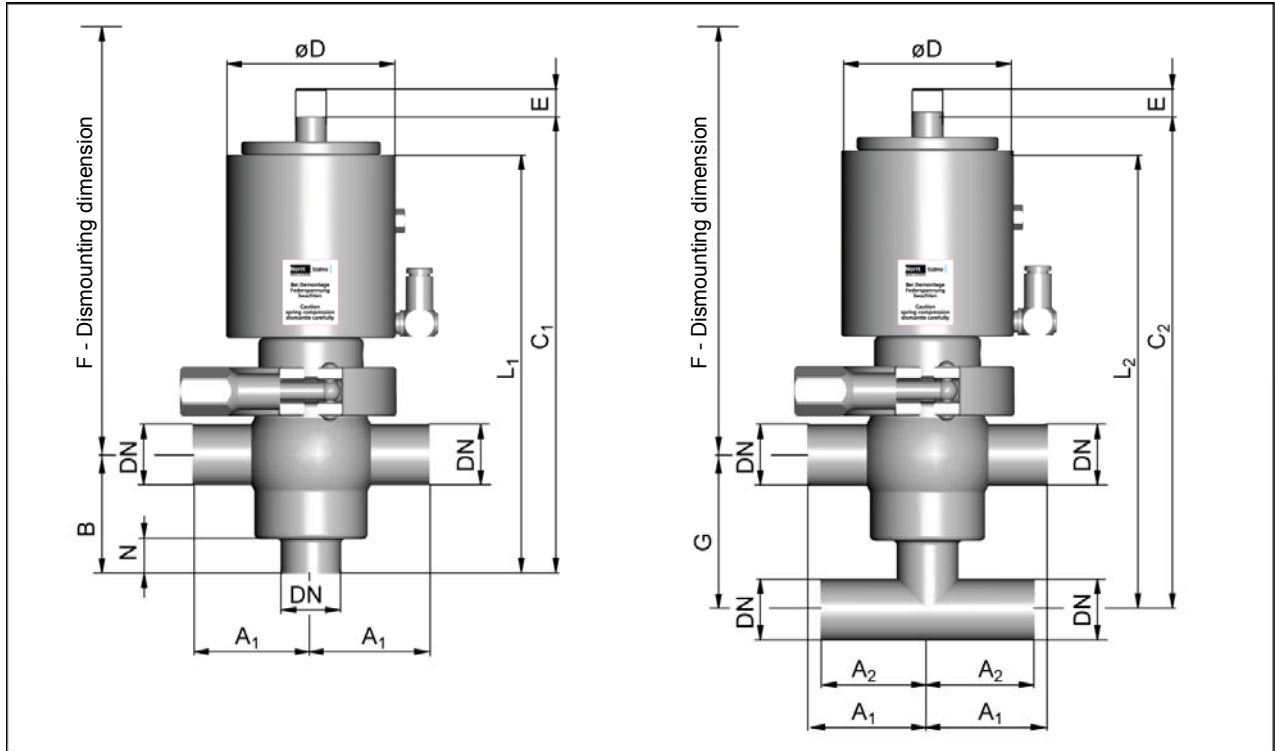

DN	Pipe	A <sub>1</sub>	A <sub>2</sub>	B	C <sub>1</sub>	C <sub>2</sub>	øD	E	F	G	L <sub>1</sub>	L <sub>2</sub>	N
Metric													
10	ø13 x 1.5	45	35	45	179.5	187	64.5	6	180	52.5	159	166.5	13
15	ø41 x 1.5	45	35	45	179.5	190	64.5	6	180	55.5	159	169.5	13
20	ø23 x 1.5	45	40	45	179.5	192	64.5	6	180	57.5	159	171.5	13

#### 3.2. Valve insert

Application:

For use in:

Shut-off tightness:

Shut-off valve

aseptic processes

Seal	DN	Shut-off tightness	Mode of operation control unit
Diaphragm – O-ring	10 - 20	6 bar max.	air to open – spring to close spring to open – air to close air to open – air to close
Diaphragm – PEEK	10 - 20	6 bar max.	air to open – spring to close spring to open – air to close air to open – air to close

### 3.3. Material data

#### Sealing materials

- ⇒ P<sup>3</sup> (diaphragm)  
 Steam sterilization: up to +160° C
- ⇒ PEEK natural color  
 Temperature for continuous application in air: from -25° C to +250° C



**The operating parameters and resistance depend on the sealing quality of the valve disk**

- ⇒ EPDM  
 Temperature for continuous application in air: -40° C to +130° C  
 Resistant to:
  - Hot water: up to 100° C
  - Steam: up to 130° C continuous load, short-term up to 150° C
  - Wort: up to 100° C
  - Sodium hydroxide: up to 100° C and a concentration of up to 5 %
  - Nitric acid: up to 60° C and a concentration of up to 3 %
  - Peracetic acid: up to 80° C and a concentration of up to 0.7 %
  - Raspberry flavor: at room temperature
  - Cherry flavor: at room temperature
- ⇒ VMQ  
 Temperature for continuous application in air: -50° C to +200° C  
 Resistant to:
  - Hot water: up to 100° C
  - Sodium hydroxide: up to 60° C and a concentration of up to 2.5 %
  - Nitric acid: up to 60° C and a concentration of up to 1.2 %
  - Peracetic acid: up to 80° C and a concentration of up to 0.7 %
- ⇒ HNBR  
 Temperature for continuous application in air: -25° C to +130° C  
 Resistant to:
  - Hot water: up to 100° C
  - Steam: up to 130° C continuous load, short-term up to 150° C
  - Sodium hydroxide: up to 100° C and a concentration of up to 5 %
  - Nitric acid: up to 60° C and a concentration of up to 1.5 %
- ⇒ FPM  
 Temperature for continuous application in air: -20° C to +200° C  
 Resistant to:
  - Hot water: up to 80° C
  - Sodium hydroxide: up to 60° C and a concentration of up to 2.5 %
  - Peracetic acid: at room temperature and a concentration of up to 0.7 %
  - Orange flavour: at room temperature
  - Mandarin flavour: at room temperature



**The operating parameters of the seals depend on:**

- ⇒ **Operating time per day**
- ⇒ **Switching intervals**
- ⇒ **Type of product, temperature etc.**
- ⇒ **Type of cleaning (CIP / SIP)**

#### Stainless steels

In contact with product: 1.4404  
 Not in contact with product: 1.4301

### 3.4. CIP cleaning



- ⇒ **Valve inner chambers must be cleaned regularly**
- ⇒ **Observe the safety data sheets issued by the detergent manufacturers!**
- ⇒ **Use only detergents that are non-aggressive and non-abrasive towards seals and stainless steel.**

### 3.5. Surfaces

Surfaces in contact with the product:

$R_a \leq 0.8 \mu\text{m}$

Optional:

electropolished

Surfaces not in contact with product:

bright metal finish,

$R_a \leq 1.6 \mu\text{m}$

### 3.6. Pneum. control unit

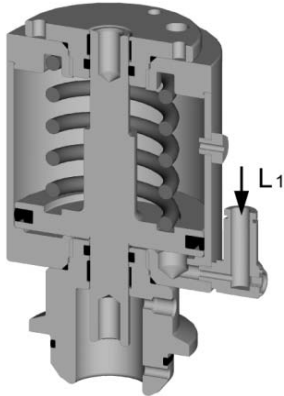

#### 3.6.1. Air to open - spring to close

- ⇒ Position "Closed"
  - Control air pressure 0 bar on connection L<sub>1</sub>.
  - Safety position
- ⇒ Position "Open"
  - Control air pressure 6 bar on connection L<sub>1</sub>.

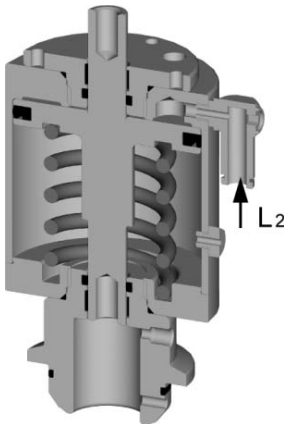

#### 3.6.2. Spring to open – air to close

- ⇒ Position "Closed"
  - Control air pressure 0 bar on connection L<sub>1</sub>.
  - Safety position
- ⇒ Position "Open"
  - Control air pressure 6 bar on connection L<sub>1</sub>.

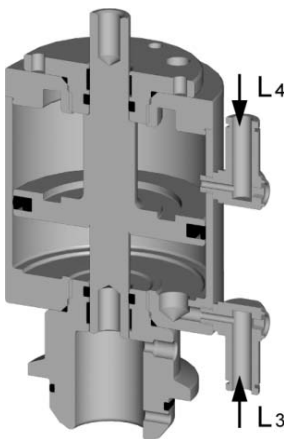

#### 3.6.3. Air to open - air to close

- ⇒ Position "Closed"
  - Control air pressure 0 bar on connection L<sub>3</sub>.
  - Control air pressure 6 bar on connection L<sub>4</sub>.
  - Safety position
- ⇒ Position "Open"
  - Control air pressure 6 bar on connection L<sub>3</sub>.
  - Control air pressure 0 bar on connection L<sub>4</sub>.

### 3.7. Feedback systems

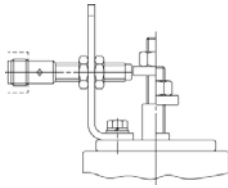

#### Simple feedback

- ⇒ Message: Valve position "Open" or "Closed"
- ⇒ Inductive feedback unit - Thread M 12 according to customer order
- ⇒ Feedback unit data - refer to data sheet of the feedback unit manufacturer
- ⇒ Add-on kit for feedback - Article no.

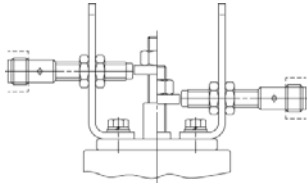

#### Double feedback

- ⇒ Message: Valve position "Open" and "Closed"
- ⇒ Inductive feedback unit - Thread M 12 according to customer order
- ⇒ Feedback unit data - refer to data sheet of the feedback unit manufacturer
- ⇒ Add-on kit for feedback - Article no.



#### Process control unit IntelliTop<sup>®</sup> Type 8680

<u>Technical data</u>	see BA 8680
<u>Pneumatic connections</u>	see BA 8680
<u>Electrical connections</u>	see BA 8680
<u>Maintenance</u>	see BA 8680

### 3.8. Electrical and pneumatic connections

#### Electrical connections

Perform the electrical installation after the installation of the fitting.



**Electrical installation must be carried out by specially trained, qualified personnel**

- ⇒ Observe VDE, power utility and other locally applicable regulations.
- ⇒ Before connecting check if operating voltage and current match specifications.

#### Pneumatic connections

- ⇒ Angular screw-in connection G 1/8, air hose PE dia. 6/4
- ⇒ USA: Angular screw-in connection G 1/8, air hose PE 1/4" (dia. 6.35)

#### Air hose

Always use hose quality according to Norit Südmo article no. 0490227 (6/4 hose) and 0735563 (8/6 hose) or similar:

- ⇒ Black air hose
- ⇒ Material: Polyamide 12  
Linear coefficient of expansion:  $15 \times 10^{-5}$   
Version according to DIN 73378 soft
- ⇒ Max. operating pressure: AD 6/ ID 4 = 27 bar  
AD 8/ ID 6 = 19 bar  
all pressure indications at 20°C, higher temperatures have a negative effect on the max. operating pressure



- ⇒ Use only calibrated hose pipes with an external diameter of 6 mm or 1/4" as well as 8 mm or 5/16" (tolerance +0.05/-0.1).
- ⇒ Cut the hose pipe only with a special hose cutter, otherwise the pipe can be damaged.



**4.2. SVP aseptic diaphragm valve spring to open – air to close**

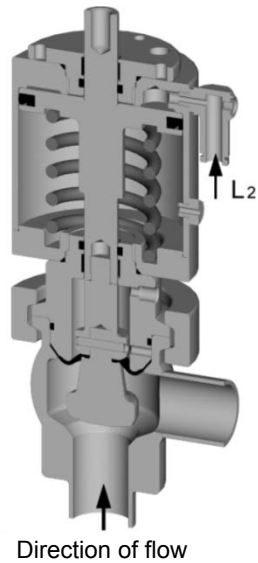

**Valve position "Closed"**

- ⇒ Control air pressure 6 bar to air connection L<sub>2</sub>
- ⇒ Closing force against product pressure 6 bar.

**Valve opens**

- ⇒ Control air pressure 0 bar to air connection L<sub>2</sub>
- ⇒ Safety position
- ⇒ Valve open

**4.3. SVP aseptic diaphragm valve air to open – air to close**

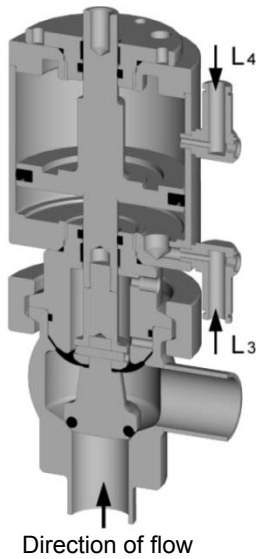

**Valve position "Closed"**

- ⇒ Control air pressure 0 bar to air connection L<sub>3</sub>
- ⇒ Control air pressure 6 bar to air connection L<sub>4</sub>
- ⇒ Safety position
- ⇒ Closing force against product pressure 6 bar.

**Valve opens**

- ⇒ Control air pressure 6 bar to air connection L<sub>3</sub>
- ⇒ Control air pressure 0 bar to air connection L<sub>4</sub>
- ⇒ Valve open

## 5. Valve connection piping

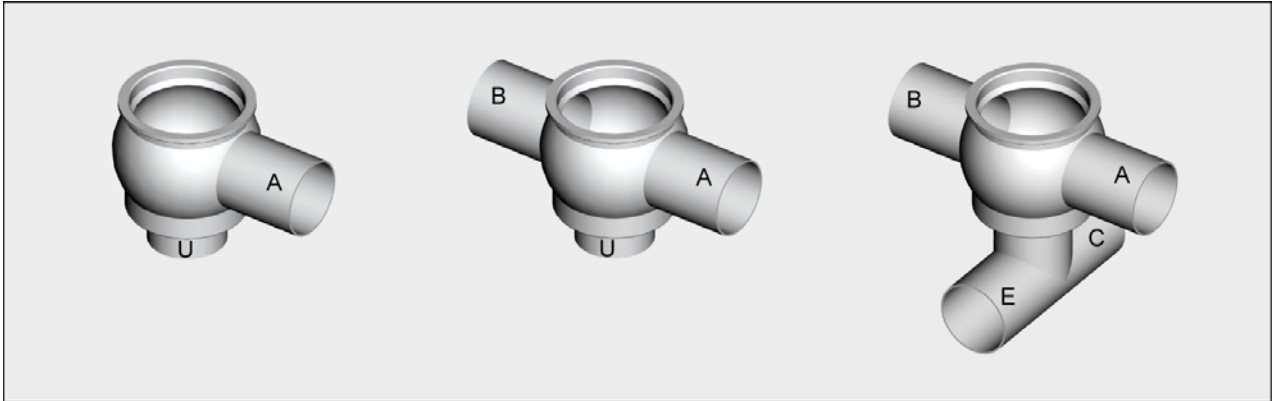

### 5.1. Installation position

Vertical, horizontal

Ensure that product can drain from valve and piping.

### 5.2. Valve connections

Connections A, B, C, E and U:

- Welding end
- Threaded connection
- Clamp connection
- Small flange connection

For welding instructions, refer to page 13.

### 5.3. Installation instructions

For valve disassembly refer to page 15.



Caution

- ⇒ ***Dismount the seals before carrying out any welding work.***
- ⇒ ***Valve body must be free from tension and distortions when welded.***
- ⇒ ***Welding work must be carried out only by qualified personnel (DIN 287-1 W11).***
- ⇒ ***Do not allow any foreign objects to enter the piping.***

## 6. Installation instructions

### 6.1. General notes

It is strongly recommended to have installation work done by specially trained, qualified personnel.



Caution

***Welding work must be carried out only by qualified personnel (DIN 287-1 W11).***

We cannot be held liable for any damage resulting from incorrect installation.

**6.2. State on delivery**

- ⇒ Factory-tested and configured.
- ⇒ Ready for installation or prepared for welding into the piping

**6.3. Installation instructions**

**6.3.1. Installation space**

Before starting the assembly work determine and define the connection axes. Observe the installation dimensions specified in the dimensional drawings.

Ensure that there is sufficient space available for both operation and maintenance.

**6.3.2. Installation**

Make sure that the fittings and piping are not subject to any tensile or compressive stresses.

**6.4. Welding instructions**

**6.4.1. Field of application**

Welding of fittings into pipes according to DIN 11850 series 1, 2; OD-Tube; DIN EN ISO 1127

**6.4.2. Welding process**

TIG (tungsten inert gas welding)

**6.4.3. Type of seam**

- ⇒ Preparation of the seam according to DIN 2559 (edge form I / for I-seams)
- ⇒ Weld seams correspond to DIN EN ISO 5817 → Quality group B (high)

**6.5. Weld seam preparation**

Saw off the pipe ends planar at the right angle and debur them (pipe saw M882). Align the welding ends of the valve body and piping radially and axially, ensuring they are fitted flush together (centering device).



**There must be no gap at the flush-fitted welding ends as the quality and corrosion resistance of the weld seam would be impaired by the escaping forming gas.**

**6.6. Welding**

Connect the forming gas. Tack at 3 or 4 points. Type of welding: TIG-manual or orbital (automatic welding).

**6.7. Weld filler**

Material allocation

Material of parts to be welded	Suitable weld filler		
	1.4430	1.4440	1.4519
1.4404	X		
1.4435	X	X	X
1.4571	X	X	

**6.8. Weld seam finishing**

**6.8.1. Interior**

Weld seam finishing not required. Improvement of surface finish by scotching (at accessible points).

### 6.8.2. Exterior

Weld finishing methods

- ⇒ Pickling - Ensure proper disposal of pickling paste
- ⇒ Brushing
- ⇒ Grinding
- ⇒ Polishing

### 6.9. Cleaning

Clean thoroughly before assembly.

### 6.10. Assembly

Carry out installation according to the assembly instructions.

## 7. Disassembly - Assembly

### 7.1. Prior to disassembly

Carry out installation according to the assembly instructions.

Before disconnecting the valve connections and the clamp connection of the valve bodies, carry out the following steps:



- ⇒ **Make sure that no process is running in the respective area during maintenance and service work.**
- ⇒ **Drain off all piping elements leading to the SVP aseptic diaphragm valve, clean and rinse them, if necessary.**
- ⇒ **Shut off the control air if it is not needed for disassembly.**
- ⇒ **When dismantling the control unit from the spring-closing valves, the closing spring must be preloaded with auxiliary assembling air.**
- ⇒ **If the closing spring is not preloaded when disassembling the control unit from the spring-closing valves, there is a risk of injury when removing the clamp connection due to release of the spring tension of the actuator.**
- ⇒ **Disconnect the power supply.**
- ⇒ **Remove the SVP aseptic diaphragm valve from the piping section, if possible.**

Prior to assembly clean and grease the shafts and sliding surfaces. Grease the sealing elements before installation.

Sealing materials	Grease type
EPDM	PARALIQ GTE 703
VMQ	BARRIERTA L 55/3
HNBR	PARALIQ GTE 703
FPM	PARALIQ GTE 703
P <sup>3</sup>	PARALIQ GTE 703
PEEK	No grease
NBR	RENOLIT SI 410 M



Caution

- ⇒ *If a different grease is used*  
→ *corrosion of the sealing elements.*
- ⇒ *For PEEK sealing elements, no grease is required.*
- ⇒ *Do not use mineral greases and animal fat.*
- ⇒ *Do not use petroleum grease.*

## 7.2. SVP aseptic diaphragm valve with feedback

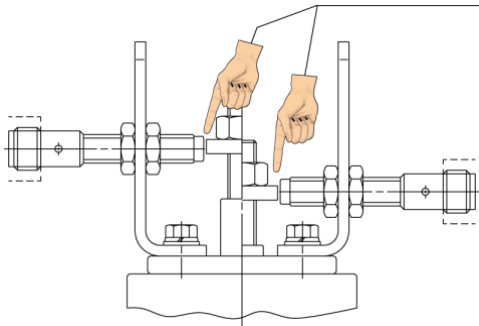

Danger

*Do not reach into the feedback unit.*

⇒ **Risk of accident.**

*Risk of limbs being crushed or cut off.*

## 7.3. Spare parts







Caution

*Use original Norit Südmo spare parts only*

- ⇒ *For Norit Südmo spare parts, refer to the enclosed spare parts list*
- ⇒ *If other spare parts are used*  
→ *Exclusion of liability*

## 7.4. Assembly tools

Tools	for	Article no.	Use
Drift punch dia. 3 	DN 10 - 20	2159236	Pneumatic SVP aseptic diaphragm valve
Drift punch dia. 5 	DN 10 - 20	2159237	Pneumatic SVP aseptic diaphragm valve
Fork wrench 17-19 mm 	DN 10 - 20	0098558	Pneumatic SVP aseptic diaphragm valve
Pin-type face spanner 	DN 10 - 20	2117744	Pneumatic SVP aseptic diaphragm valve

**7.5. Replacement of the seals in contact with the product**

**7.5.1. Pneumatic SVP aseptic diaphragm valve, air to open - spring to close**



**Avoid any damage to the metallic surfaces of the valve disks and to the valve disk seals.**

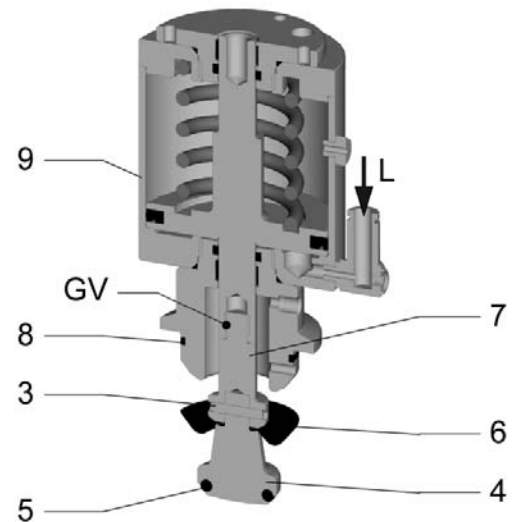
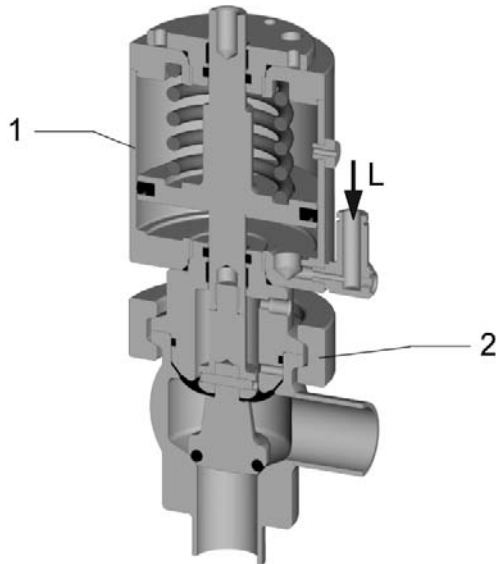

Disassembling the valve

- I.1. Disconnect electrical cables and pneumatic lines.
- I.2. Preload actuator spring.



**⇒ Control air pressure min. 5 bar (auxiliary assembly air) to connection L.**

- I.3. Remove the clamp (2).
- I.4. Release the actuator spring.



**⇒ Control air pressure 0 bar (auxiliary assembly air) to connection L.  
⇒ Upper part comes out of the housing  
⇒ Disconnect compressed air line.**

- I.5. Remove the upper part of the valve (1).
- I.6. Dismount the stem (7) with the valve disk (4) and the diaphragm (6).
- I.7. Clamp the stem (7) with the valve disk (4) and diaphragm (6) in the vice and dismount the cylinder pin (3) with the drift punch  $\varnothing 3$ .



**Avoid damage to the stem (7), diaphragm (6) and the valve disk (4).**

- I.8. Remove the valve disk (4) and the diaphragm (6) from the stem (7).
- I.9. Remove the O-ring (5).
- I.10. Remove the O-ring (8).

Replacing the seal

I.11. Replace the seals and friction bearings.

 **Use original Norit Südmo spare parts only**  
**For Norit Südmo spare parts, refer to the enclosed spare parts list**  
**If other spare parts are used**  
**→ Exclusion of liability**

I.12. Grease the sealing elements before installation.

Sealing materials	Grease type
EPDM	PARALIQ GTE 703
VMQ	BARRIERTA L 55/3
HNBR	PARALIQ GTE 703
FPM	PARALIQ GTE 703
P <sup>3</sup>	PARALIQ GTE 703
NBR	RENOLIT SI 410 M

 ⇒ **If a different grease is used**  
 ⇒ **→ corrosion of the sealing elements.**  
 ⇒ **Do not use mineral greases and animal fat.**  
 ⇒ **Do not use petroleum grease.**

Assembling the valve

I.13. Prior to assembly clean and grease the shafts and sliding surfaces.

I.14. Install the O-ring (8).

I.15. Install the diaphragm (6) on the stem (7).

 **Prior to assembly grease the inner surface of the diaphragm according to the lubrication plan.**

I.16. Clamp the stem (7) with the valve disk (4) and diaphragm (6) in the vice and mount the cylinder pin (3) with the drift punch ø3.

 **Avoid damage to the stem (7), diaphragm (6) and the valve disk (4).**

I.17. Remove the stem (7) with the valve disk (4) and diaphragm (6) from the vice.

I.18. Install the O-ring (5) in the valve disk (4) (see Chapter 7.6. page 28).

I.19. Install the stem (7) with the valve disk (4) and diaphragm (6) on the piston rod of the drive (9).

 **Secure the threaded connection GV with adhesive (article no. 0630210).**

I.20. Preload actuator spring.

 ⇒ **Control air pressure min. 5 bar (auxiliary assembly air) to connection L.**

I.21. Insert the upper part of the valve (1) into the valve body and mount clamp (2).

I.22. Release the actuator spring.



⇒ **Control air pressure min. 0 bar (auxiliary assembly air) to connection L.**

I.23. Install electrical cables and pneumatic lines.

7.5.2. Pneumatic SVP aseptic diaphragm valve, spring to open - air to close - Diaphragm - O-ring



**Avoid any damage to the metallic surfaces of the valve disks and to the valve disk seals.**

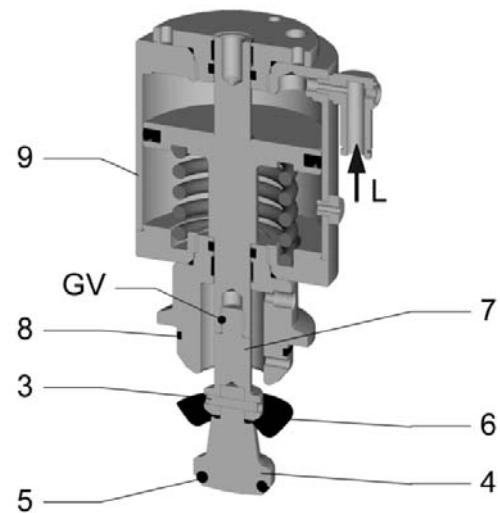
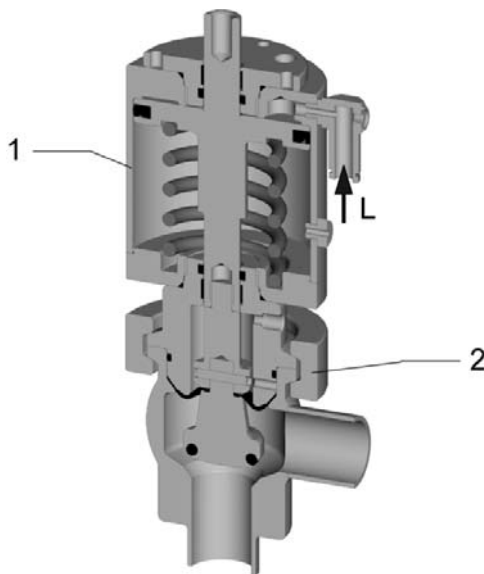

Disassembling the valve

- II.1. Disconnect electrical cables and pneumatic lines.
- II.2. Remove the clamp (2).
- II.3. Remove the upper part of the valve (1).
- II.4. Preload actuator spring.



⇒ **Control air pressure min. 5 bar (auxiliary assembly air) to connection L.**

- II.5. Dismount the stem (7) with the valve disk (4) and the diaphragm (6).
- II.6. Release the actuator spring.



⇒ **Control air pressure 0 bar (auxiliary assembly air) to connection L.**  
⇒ **Upper part comes out of the housing**  
⇒ **Disconnect compressed air line.**

II.7. Clamp the stem (7) with the valve disk (4) and diaphragm (6) in the vice and dismount the cylinder pin (3) with the drift punch  $\varnothing 3$ .



**Avoid damage to the stem (7), diaphragm (6) and the valve disk (4).**

- II.8. Remove the valve disk (4) and the diaphragm (6) from the stem (7).
- II.9. Remove the O-ring (5).
- II.10. Remove the O-ring (8).

Replacing the seal

- II.11. Replace the seals and friction bearings.



**Use original Norit Südmo spare parts only**

- ⇒ **For Norit Südmo spare parts, refer to the enclosed spare parts list**
- ⇒ **If other spare parts are used**
- **Exclusion of liability**

**Caution**

- II.12. Grease the sealing elements before installation.

Sealing materials	Grease type
EPDM	PARALIQ GTE 703
VMQ	BARRIERTA L 55/3
HNBR	PARALIQ GTE 703
FPM	PARALIQ GTE 703
P <sup>3</sup>	PARALIQ GTE 703
NBR	RENOLIT SI 410 M



- ⇒ **If a different grease is used**
- **corrosion of the sealing elements.**
- ⇒ **Do not use mineral greases and animal fat.**
- ⇒ **Do not use petroleum grease.**

**Caution**

Assembling the valve

- II.13. Prior to assembly clean and grease the shafts and sliding surfaces.
- II.14. Install the O-ring (8).
- II.15. Install the diaphragm (6) on the stem (7).



**Prior to assembly grease the inner surface of the diaphragm according to the lubrication plan.**

**Danger**

- II.16. Clamp the stem (7) with the valve disk (4) and diaphragm (6) in the vice and mount the cylinder pin (3) with the drift punch ø3.



**Avoid damage to the stem (7), diaphragm (6) and the valve disk (4).**

**Caution**

- II.17. Remove the stem (7) with the valve disk (4) and diaphragm (6) from the vice.
- II.18. Install the O-ring (5) in the valve disk (4) (see Chapter 7.6. page 28).
- II.19. Preload actuator spring.



⇒ **Control air pressure min. 5 bar (auxiliary assembly air) to connection L.**

**Danger**

- II.20. Install the stem (7) with the valve disk (4) and diaphragm (6) on the piston rod of the drive (9).



**Secure the threaded connection GV with adhesive (article no. 0630210).**

**Caution**

II.21. Release the actuator spring.

 ⇒ **Control air pressure min. 0 bar (auxiliary assembly air) to connection L.**  
**Danger**

II.22. Insert the upper part of the valve (1) into the valve body and mount clamp (2).

II.23. Install electrical cables and pneumatic lines.

**7.5.3. Pneumatic SVP aseptic diaphragm valve, air to open - air to close - Diaphragm - O-ring**

 **Avoid any damage to the metallic surfaces of the valve disks and to the valve disk seals.**  
**Caution**

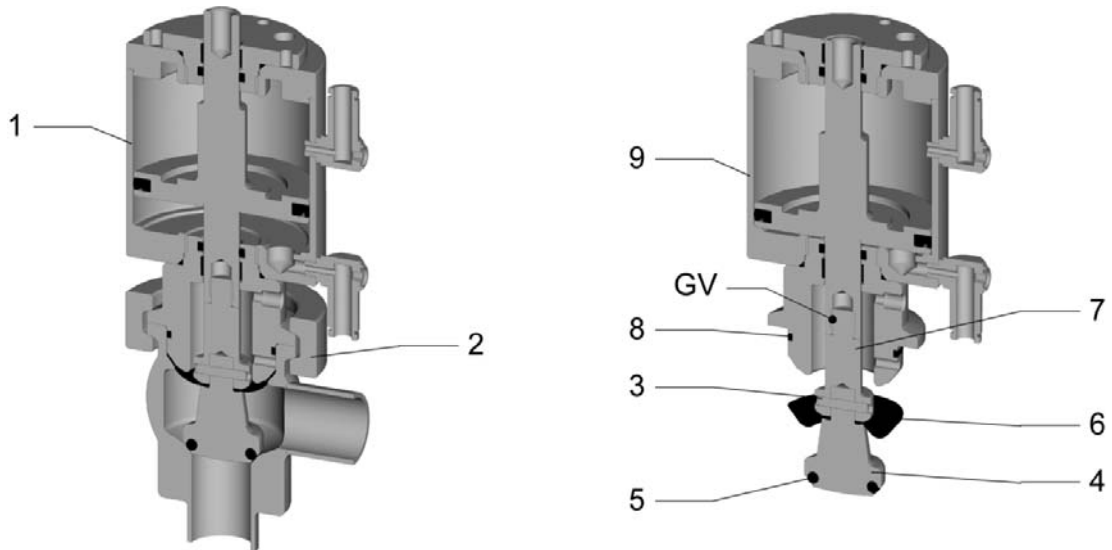

Disassembling the valve

III.1. Disconnect electrical cables and pneumatic lines.

III.2. Remove the clamp (2).

III.3. Remove the upper part of the valve (1).

III.4. Dismount the stem (7) with the valve disk (4) and the diaphragm (6).

III.5. Clamp the stem (7) with the valve disk (4) and diaphragm (6) in the vice and dismount the cylinder pin (3) with the drift punch ø3.

 **Avoid damage to the stem (7), diaphragm (6) and the valve disk (4).**  
**Caution**

III.6. Remove the valve disk (4) and the diaphragm (6) from the stem (7).

III.7. Remove the O-ring (5).

III.8. Remove the O-ring (8).

Replacing the seal

III.9. Replace the seals and friction bearings.

 **Use original Norit Südmo spare parts only**  
 ⇒ **For Norit Südmo spare parts, refer to the enclosed spare parts list**  
 ⇒ **If other spare parts are used**  
 → **Exclusion of liability**

III.10. Grease the sealing elements before installation.

Sealing materials	Grease type
EPDM	PARALIQ GTE 703
VMQ	BARRIERTA L 55/3
HNBR	PARALIQ GTE 703
FPM	PARALIQ GTE 703
P <sup>3</sup>	PARALIQ GTE 703
NBR	RENOLIT SI 410 M



Caution

- ⇒ **If a different grease is used**  
 → **corrosion of the sealing elements.**
- ⇒ **Do not use mineral greases and animal fat.**
- ⇒ **Do not use petroleum grease.**

Assembling the valve

III.11. Prior to assembly clean and grease the shafts and sliding surfaces.

III.12. Install the O-ring (8).

III.13. Install the diaphragm (6) on the stem (7).



Danger

**Prior to assembly grease the inner surface of the diaphragm according to the lubrication plan.**

III.14. Clamp the stem (7) with the valve disk (4) and diaphragm (6) in the vice and mount the cylinder pin (3) with the drift punch ø3.



Caution

**Avoid damage to the stem (7), diaphragm (6) and the valve disk (4).**

III.15. Remove the stem (7) with the valve disk (4) and diaphragm (6) from the vice.

III.16. Install the O-ring (5) in the valve disk (4) (see Chapter 7.6. page 28).

III.17. Install the stem (7) with the valve disk (4) and diaphragm (6) on the piston rod of the drive (9).



Caution

**Secure the threaded connection GV with adhesive (article no. 0630210).**

III.18. Insert the upper part of the valve (1) into the valve body and mount clamp (2).

III.19. Install electrical cables and pneumatic lines.

**7.5.4. Pneumatic SVP aseptic diaphragm valve, air to open - spring to close - Diaphragm - PEEK**



Caution

**Avoid any damage to the metallic surfaces of the valve disks and to the valve disk seals.**

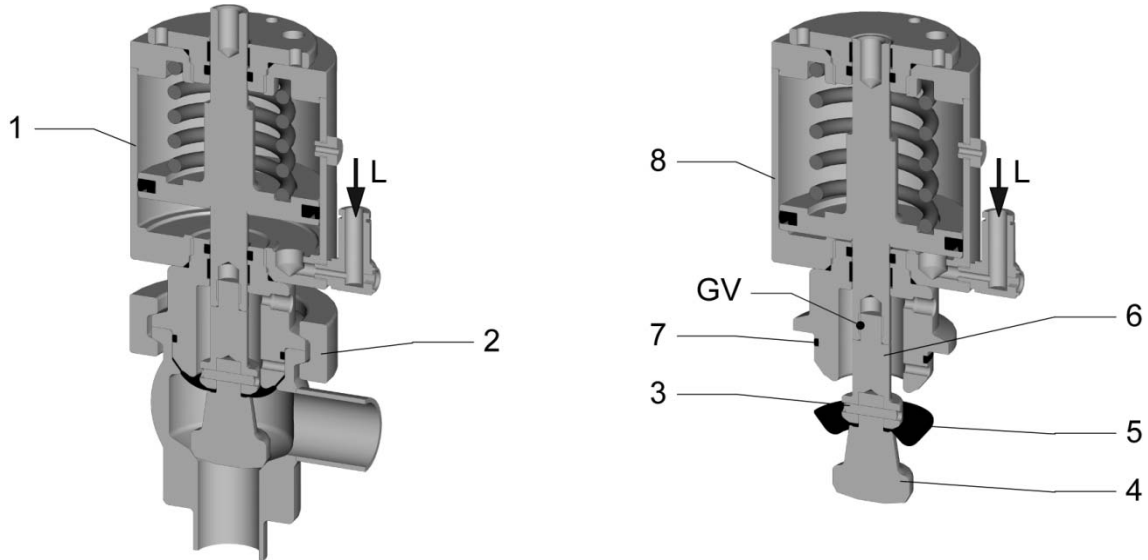

Disassembling the valve

- I.24. Disconnect electrical cables and pneumatic lines.
- I.25. Preload actuator spring.



Danger

⇒ **Control air pressure min. 5 bar (auxiliary assembly air) to connection L.**

- I.26. Remove the clamp (2).
- I.27. Release the actuator spring.



Danger

⇒ **Control air pressure 0 bar (auxiliary assembly air) to connection L.**  
⇒ **Upper part comes out of the housing**  
⇒ **Disconnect compressed air line.**

- I.28. Remove the upper part of the valve (1).
- I.29. Dismount the stem (7) with the valve disk (4) and the diaphragm (6).
- I.30. Clamp the stem (7) with the valve disk (4) and diaphragm (6) in the vice and dismount the cylinder pin (3) with the drift punch  $\varnothing 3$ .



Caution

**Avoid damage to the stem (7), diaphragm (6) and the valve disk (4).**

- I.31. Remove the valve disk (4) and the diaphragm (6) from the stem (7).
- I.32. Remove the O-ring (8).

Replacing the seal

- I.33. Replace the seals and friction bearings.

 **Use original Norit Südmo spare parts only**  
 ⇒ **For Norit Südmo spare parts, refer to the enclosed spare parts list**  
 ⇒ **If other spare parts are used**  
 → **Exclusion of liability**

I.34. Grease the sealing elements before installation.

Sealing materials	Grease type
EPDM	PARALIQ GTE 703
VMQ	BARRIERTA L 55/3
HNBR	PARALIQ GTE 703
FPM	PARALIQ GTE 703
P <sup>3</sup>	PARALIQ GTE 703
NBR	RENOLIT SI 410 M

 ⇒ **If a different grease is used**  
 → **corrosion of the sealing elements.**  
 ⇒ **Do not use mineral greases and animal fat.**  
 ⇒ **Do not use petroleum grease.**

Assembling the valve

I.35. Prior to assembly clean and grease the shafts and sliding surfaces.

I.36. Install the O-ring (8).

I.37. Install the diaphragm (6) on the stem (7).

 **Prior to assembly grease the inner surface of the diaphragm according to the lubrication plan.**

I.38. Clamp the stem (7) with the valve disk (4) and diaphragm (6) in the vice and mount the cylinder pin (3) with the drift punch ø3.

 **Avoid damage to the stem (7), diaphragm (6) and the valve disk (4).**

I.39. Remove the stem (7) with the valve disk (4) and diaphragm (6) from the vice.

I.40. Install the stem (7) with the valve disk (4) and diaphragm (6) on the piston rod of the drive (9).

 **Secure the threaded connection GV with adhesive (article no. 0630210).**

I.41. Preload actuator spring.

 ⇒ **Control air pressure min. 5 bar (auxiliary assembly air) to connection L.**

I.42. Insert the upper part of the valve (1) into the valve body and mount clamp (2).

I.43. Release the actuator spring.

 ⇒ **Control air pressure min. 0 bar (auxiliary assembly air) to connection L.**

I.44. Install electrical cables and pneumatic lines.

**7.5.5. Pneumatic SVP aseptic diaphragm valve, spring to open - air to close - Diaphragm - PEEK**



**Avoid any damage to the metallic surfaces of the valve disks and to the valve disk seals.**

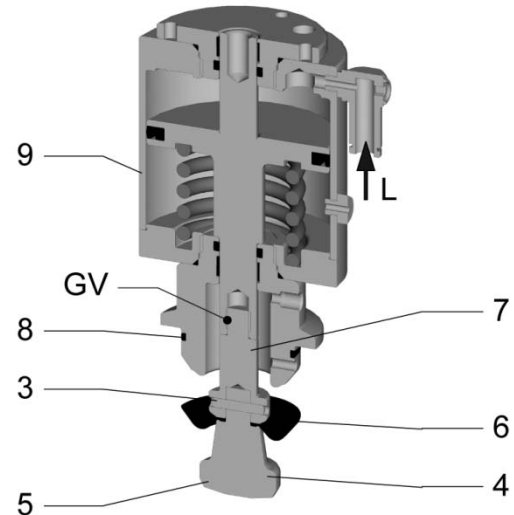
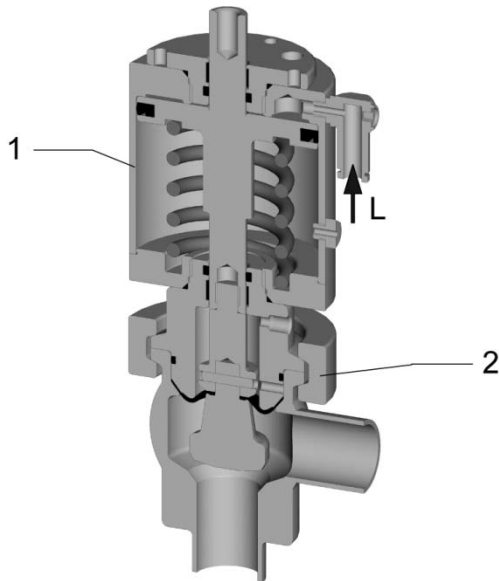

Disassembling the valve

- V.1. Disconnect electrical cables and pneumatic lines.
- V.2. Remove the clamp (2).
- V.3. Remove the upper part of the valve (1).
- V.4. Preload actuator spring.



⇒ **Control air pressure min. 5 bar (auxiliary assembly air) to connection L.**

- V.5. Dismount the stem (7) with the valve disk (4) and the diaphragm (6).
- V.6. Release the actuator spring.



⇒ **Control air pressure 0 bar (auxiliary assembly air) to connection L.**  
⇒ **Upper part comes out of the housing**  
⇒ **Disconnect compressed air line.**

- V.7. Clamp the stem (7) with the valve disk (4) and diaphragm (6) in the vice and dismount the cylinder pin (3) with the drift punch ø3.



**Avoid damage to the stem (7), diaphragm (6) and the valve disk (4).**

- V.8. Remove the valve disk (4) and the diaphragm (6) from the stem (7).
- V.9. Remove the O-ring (8).

Replacing the seal

II.24. Replace the seals and friction bearings.



Caution

**Use original Norit Südmo spare parts only**

- ⇒ **For Norit Südmo spare parts, refer to the enclosed spare parts list**
- ⇒ **If other spare parts are used**
- **Exclusion of liability**

V.10. Grease the sealing elements before installation.

Sealing materials	Grease type
EPDM	PARALIQ GTE 703
VMQ	BARRIERTA L 55/3
HNBR	PARALIQ GTE 703
FPM	PARALIQ GTE 703
P <sup>3</sup>	PARALIQ GTE 703
NBR	RENOLIT SI 410 M



Caution

- ⇒ **If a different grease is used**
- **corrosion of the sealing elements.**
- ⇒ **Do not use mineral greases and animal fat.**
- ⇒ **Do not use petroleum grease.**

Assembling the valve

- V.11. Prior to assembly clean and grease the shafts and sliding surfaces.
- V.12. Install the O-ring (8).
- V.13. Install the diaphragm (6) on the stem (7).



Danger

**Prior to assembly grease the inner surface of the diaphragm according to the lubrication plan.**

V.14. Clamp the stem (7) with the valve disk (4) and diaphragm (6) in the vice and mount the cylinder pin (3) with the drift punch ø3.



Caution

**Avoid damage to the stem (7), diaphragm (6) and the valve disk (4).**

- V.15. Remove the stem (7) with the valve disk (4) and diaphragm (6) from the vice.
- V.16. Preload actuator spring.



Danger

⇒ **Control air pressure min. 5 bar (auxiliary assembly air) to connection L.**

V.17. Install the stem (7) with the valve disk (4) and diaphragm (6) on the piston rod of the drive (9).



Caution

**Secure the threaded connection GV with adhesive (article no. 0630210).**

V.18. Release the actuator spring.



Danger

⇒ **Control air pressure min. 0 bar (auxiliary assembly air) to connection L.**

- V.19. Insert the upper part of the valve (1) into the valve body and mount clamp (2).
- V.20. Install electrical cables and pneumatic lines.

**7.5.6. Pneumatic SVP aseptic diaphragm valve, air to open - air to close - Diaphragm - PEEK**



*Avoid any damage to the metallic surfaces of the valve disks and to the valve disk seals.*

**Caution**

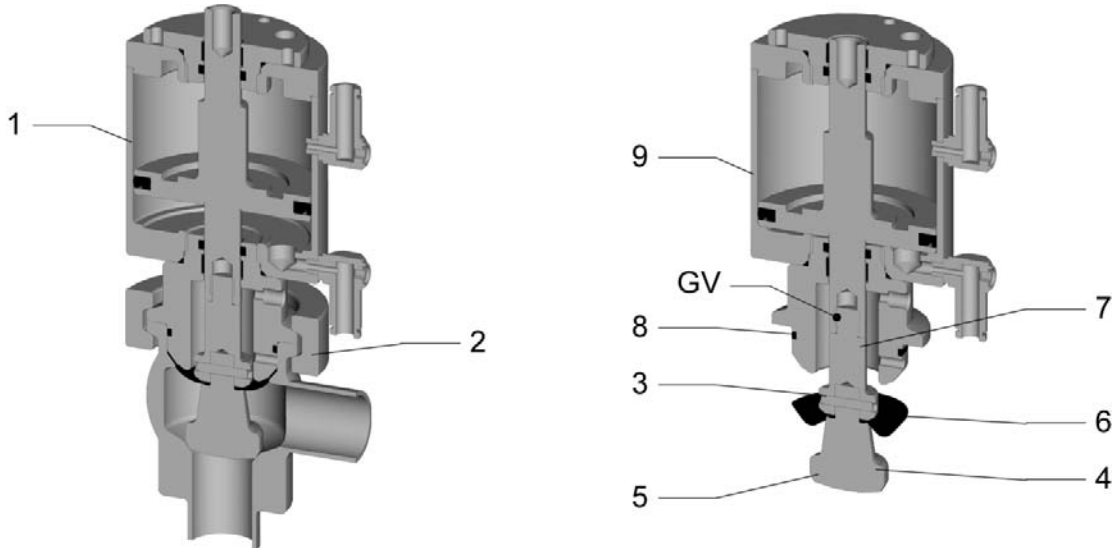

Disassembling the valve

- VI.1. Disconnect electrical cables and pneumatic lines.
- VI.2. Remove the clamp (2).
- VI.3. Remove the upper part of the valve (1).
- VI.4. Dismount the stem (7) with the valve disk (4) and the diaphragm (6).
- VI.5. Clamp the stem (7) with the valve disk (4) and diaphragm (6) in the vice and dismount the cylinder pin (3) with the drift punch ø3.



*Avoid damage to the stem (7), diaphragm (6) and the valve disk (4).*

**Caution**

- VI.6. Remove the valve disk (4) and the diaphragm (6) from the stem (7).
- VI.7. Remove the O-ring (8).

Replacing the seal

- VI.8. Replace the seals and friction bearings.



*Use original Norit Südmo spare parts only*

*⇒ For Norit Südmo spare parts, refer to the enclosed spare parts list*

*⇒ If other spare parts are used*

*→ Exclusion of liability*

- VI.9. Grease the sealing elements before installation.

Sealing materials	Grease type
EPDM	PARALIQ GTE 703
VMQ	BARRIERTA L 55/3
HNBR	PARALIQ GTE 703
FPM	PARALIQ GTE 703
P <sup>3</sup>	PARALIQ GTE 703
NBR	RENOLIT SI 410 M

 **Caution**

- ⇒ *If a different grease is used*
- ⇒ *corrosion of the sealing elements.*
- ⇒ *Do not use mineral greases and animal fat.*
- ⇒ *Do not use petroleum grease.*

Assembling the valve

- VI.10. Prior to assembly clean and grease the shafts and sliding surfaces.
- VI.11. Install the O-ring (8).
- VI.12. Install the diaphragm (6) on the stem (7).

 **Danger**

**Prior to assembly grease the inner surface of the diaphragm according to the lubrication plan.**

- VI.13. Clamp the stem (7) with the valve disk (4) and diaphragm (6) in the vice and mount the cylinder pin (3) with the drift punch  $\varnothing 3$ .

 **Caution**

**Avoid damage to the stem (7), diaphragm (6) and the valve disk (4).**

- VI.14. Remove the stem (7) with the valve disk (4) and diaphragm (6) from the vice.
- VI.15. Install the stem (7) with the valve disk (4) and diaphragm (6) on the piston rod of the drive (9).

 **Caution**

**Secure the threaded connection GV with adhesive (article no. 0630210).**

- VI.16. Insert the upper part of the valve (1) into the valve body and mount clamp (2).
- VI.17. Install electrical cables and pneumatic lines.

**7.6. Assembling the O-ring**

**7.6.1. Disassembly**

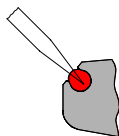

- ⇒ The O-ring is installed in positive contact under pretension.
- ⇒ Remove the O-ring as shown in the drawing.

 **Caution**

**Do not damage the seal groove (edges of the groove).**

**7.6.2. Installation**

- ⇒ Press the O-ring in sequence 1- 2, 3 – 4 etc. into the groove.
- ⇒ Roll the O-ring section by section 1 – 6, 5 – 2 into the groove.
- ⇒ For the assembly use round objects made of plastic or wood.

 **Caution**

**Avoid twisting and damaging the O-ring.**

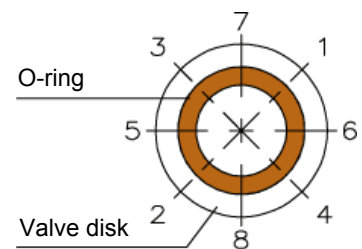

**7.7. Pneum. control unit**

**7.7.1. Operating mode air to open - spring to close**

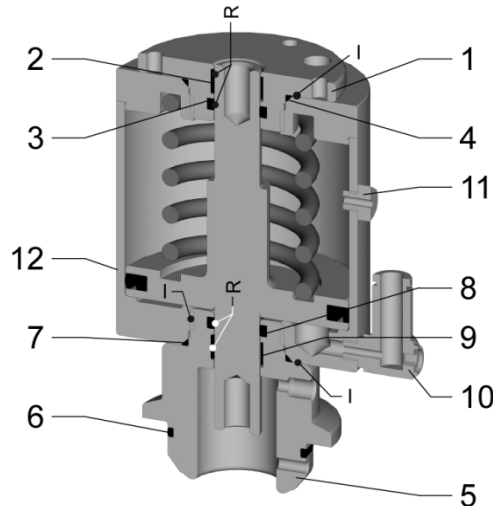

Disassembling the actuator

- VII.1. Unscrew the threaded plug (11).
- VII.2. Disconnect the air connection (10).
- VII.3. Unscrew the centering screw (1) and remove the friction bearing (2) and O-rings (3, 4).

Assembly tool

- Pin-type face spanner

- VII.4. Dismantle the closing head support (5) and remove the friction bearing (9) and O-rings (6, 7, 8).

Assembly tool

- Drift punch ø5

Replacing the seal

- VII.5. Replace the seals and friction bearings.



**Use original Norit Südmo spare parts only**

⇒ **For Norit Südmo spare parts, refer to the enclosed spare parts list**

⇒ **If other spare parts are used  
 → Exclusion of liability**

- VII.6. Prior to assembly clean and grease the shafts and sliding surfaces. Grease the sealing elements before installation.

Lubrication plan

- Apply R = RENOLIT SI 410 M - at the periphery using a brush
- Skim I = IFB PW 119 - at the periphery using a brush

Assembling the actuator

- VII.7. Install the friction bearing (9) and O-rings (6, 7, 8) in the closing head support (5).
- VII.8. Screw the closing head support (5) onto the actuator cylinder (12).

Assembly tool

- Drift punch ø5

- VII.9. Install the friction bearing (2) and O-rings (3, 4) in the centering screw (1).
- VII.10. Screw the centering screw (1) onto the drive cylinder (12).

Assembly tool

- Pin-type face spanner

- VII.11. Unscrew the threaded plug (11).
- VII.12. Reconnect the air connection (10)

**7.7.2. Operating mode spring to open - air to close**

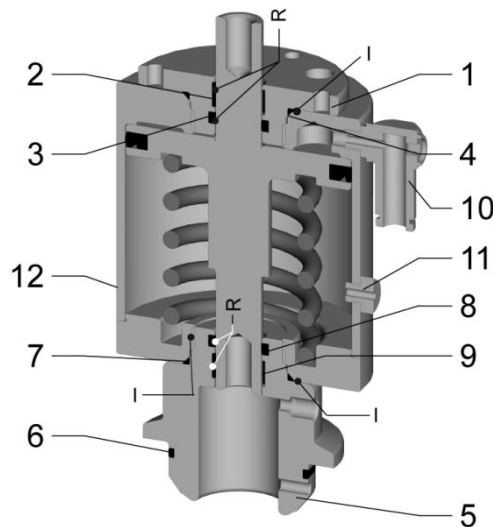

Disassembling the actuator

- VIII.1. Unscrew the threaded plug (11).
- VIII.2. Disconnect the air connection (10).
- VIII.3. Unscrew the centering screw (1) and remove the friction bearing (2) and O-rings (3, 4).

Assembly tool

- Pin-type face spanner

- VIII.4. Dismantle the closing head support (5) and remove the friction bearing (9) and O-rings (6, 7, 8).

Assembly tool

- Drift punch ø5

Replacing the seal

- VIII.5. Replace the seals and friction bearings.



**Use original Norit Südmo spare parts only**

⇒ **For Norit Südmo spare parts, refer to the enclosed spare parts list**

⇒ **If other spare parts are used**

→ **Exclusion of liability**

- VIII.6. Prior to assembly clean and grease the shafts and sliding surfaces. Grease the sealing elements before installation.

Lubrication plan

- Apply R = RENOLIT SI 410 M - at the periphery using a brush
- Skim I =I FB PW 119 - at the periphery using a brush

Assembling the actuator

- VIII.7. Install the friction bearing (9) and O-rings (6, 7, 8) in the closing head support (5).
- VIII.8. Screw the closing head support (5) onto the actuator cylinder (12).

Assembly tool

- Drift punch ø5

- VIII.9. Install the friction bearing (2) and O-rings (3, 4) in the centering screw (1).
- VIII.10. Screw the centering screw (1) onto the drive cylinder (12).

Assembly tool

- Pin-type face spanner

- VIII.11. Unscrew the threaded plug (11).
- VIII.12. Reconnect the air connection (10)

**7.7.3. Mode of operation air to open - air to close**

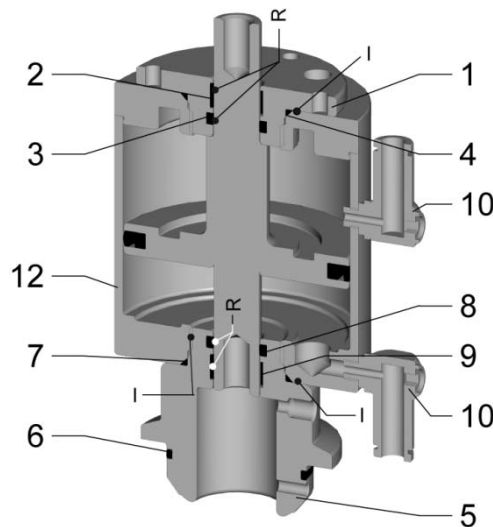

Disassembling the actuator

IX.1. Dismounting the air connections (10).

IX.2. Unscrew the centering screw (1) and remove the friction bearing (2) and O-rings (3, 4).

Assembly tool

- Pin-type face spanner

IX.3. Dismantle the closing head support (5) and remove the friction bearing (9) and O-rings (6, 7, 8).

Assembly tool

- Drift punch ø5

Replacing the seal

IX.4. Replace the seals and friction bearings.



**Use original Norit Südmo spare parts only**

**⇒ For Norit Südmo spare parts, refer to the enclosed spare parts list**

**⇒ If other spare parts are used**

**→ Exclusion of liability**

IX.5. Prior to assembly clean and grease the shafts and sliding surfaces. Grease the sealing elements before installation.

Lubrication plan

Apply R = RENOLIT SI 410 M - at the periphery using a brush

Skim I =IFB PW 119 - at the periphery using a brush

Assembling the actuator

IX.6. Install the friction bearing (9) and O-rings (6, 7, 8) in the closing head support (5).

IX.7. Screw the closing head support (5) onto the actuator cylinder (12).

Assembly tool

- Drift punch ø5

IX.8. Install the friction bearing (2) and O-rings (3, 4) in the centering screw (1).

IX.9. Screw the centering screw (1) onto the drive cylinder (12).

Assembly tool

- Pin-type face spanner

IX.10. Installing the air connections (10).

**7.8. Installation of the process control unit IntelliTop® Type 8680**

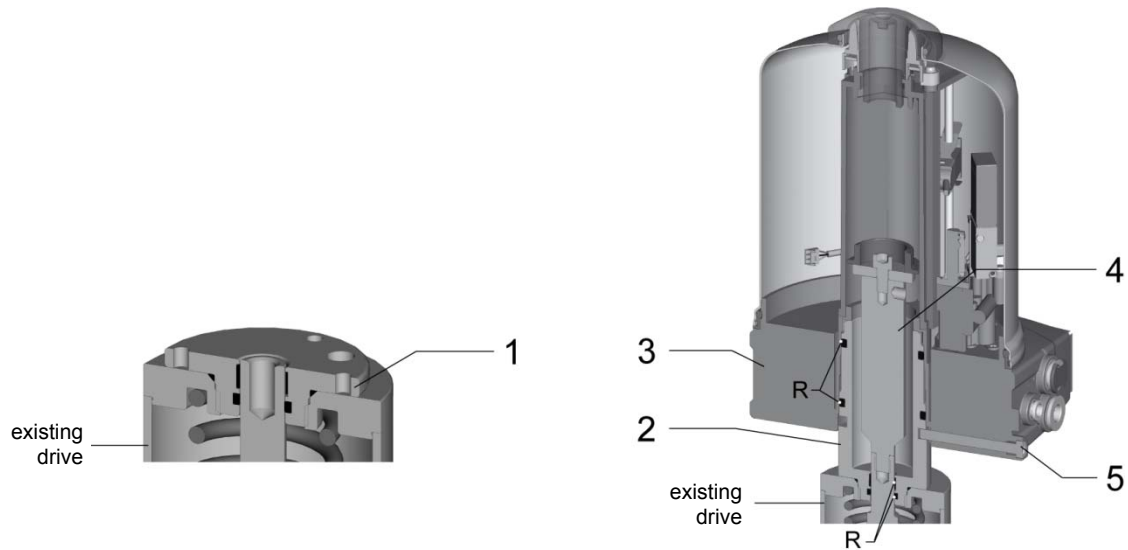

- X.1. Unscrew centering screw (1).
- X.2. Install adapter (2). Prior to assembly clean and grease the shafts and sliding surfaces. Grease the sealing elements before installation.  
Lubrication plan  
 Apply R = RENOLIT SI 410 M - at the periphery using a brush
- X.3. Install contact button (4).
- X.4. Plug process control unit (3) onto adapter (2).
- X.5. Screw on the cap screw (5).

## 8. Start-up



Caution

- ⇒ **Ensure that no foreign objects are present in the piping system.**
- ⇒ **Avoid temperature shock!**  
**Warm up the fitting slowly to the operating temperature.**

### 8.1. Functional test

#### 8.1.1. Pneumatic design

Switch the valve several times by activation with compressed air.  
The system must be cleaned before the first product run.

### 8.2. Leak test

Check visually if the seals have any leaks.  
Replace defective seals.

## 9. Maintenance

### 9.1. Before maintenance



Danger

- ⇒ **Depressurize piping system, drain all liquids and shut off control air supply.**
- ⇒ **For spring-closed valves, the closing spring must be preloaded using auxiliary assembly air.**
- ⇒ **If the closing spring is not preloaded when disassembling the control unit from the spring-closing valves, there is a risk of injury when removing the clamp connection due to release of the spring tension of the actuator.**
- ⇒ **Observe the electrical supply voltage, switch off the power supply if necessary.**
- ⇒ **Maintenance work must be carried out by qualified and trained personnel only.**

### 9.2. Inspection

Norit Südmo valves do not require special maintenance. In the intervals between maintenance procedures, however, it is necessary to check the tightness and correct operation of the seals by means of regular visual inspections.

### 9.3. Maintenance

Practice-oriented maintenance intervals can only be determined by the respective user/operator as they depend on the following application parameters:

- ⇒ Operating time per day
- ⇒ Switching intervals
- ⇒ Type of product
- ⇒ Type of cleaning (CIP / SIP)

We can recommend the following data as reference values:

- ⇒ for liquids with solid particles and temperatures of 80° C to 100° C approx. every 3-6 months
- ⇒ for liquids with solid particles and temperatures of 60° C every 12 months
- ⇒ for liquids without solid particles and temperatures of max. 60° C every 24 months.

Intervals of 12 months are recommended for cleaning systems.

Of course, the intervals stated above require sufficient chemical resistance of the sealing materials.

## 10. Malfunctions - Troubleshooting



Danger

- ⇒ **Never touch the valve or the pipelines if hot media are processed or if the sterilizing process is running.**
- ⇒ **Always adhere to the technical data.**
- ⇒ **We cannot be held liable for improper operation of the valve.**



Caution

- ⇒ **In case of malfunctions, shut off the valve immediately and secure it against restart.**
- ⇒ **Malfunctions must be eliminated by qualified and trained personnel only while observing the safety instructions.**

Malfunctions	Cause	Troubleshooting
Valve does not work	⇒ Fault in the control system	⇒ Check the system configuration
	⇒ No compressed air	⇒ Check compressed air supply
	⇒ Compressed air level is too low	⇒ Check if air hoses are free and tight
	⇒ Fault in the electrical system	⇒ Check activation / process control unit and electrical lines
Air escapes from the actuator	⇒ Pilot valve is defective	⇒ Replace the pilot valve
	⇒ Seal on the stem is defective	⇒ Replace the seals
	⇒ Seals in the actuator are defective	⇒ Replace the actuator cylinder
Valve does not close	⇒ Dirt / foreign objects in the seat area	⇒ Clean the valve body and the area of the seal, valve disk/closing diaphragm
Valve closes too slowly	⇒ Seals in the actuator are dry (friction losses)	⇒ Grease the seals - See lubrication plan
Leakage on support or stem lead-through	⇒ Seals are defective	⇒ Replace the seals
Valve closes jerkily	⇒ Seals are dry (friction losses)	⇒ Grease the seals - See lubrication plan
		⇒ Replace the seals

## 11. Disposal

### 11.1. Before disposal

Carry out the assembly according to the assembly instructions (page 16 - 33).

Prior to disposal of the SVP aseptic diaphragm valve the following steps must be carried out:



- ⇒ *Make sure that no process is running in the respective area.*
- ⇒ *Drain off all piping elements leading to the SVP aseptic diaphragm valve, clean and rinse them, if necessary.*
- ⇒ *Shut off the control air if it is not needed for disassembly.*
- ⇒ *When dismantling the control unit from the spring-closing valves, the closing spring must be preloaded with auxiliary assembling air.*
- ⇒ *If the closing spring is not preloaded when disassembling the control unit from the spring-closing valves, there is a risk of injury when removing the clamp connection due to release of the spring tension of the actuator.*
- ⇒ *Disconnect the power supply.*

### 11.2. Components of the SVP aseptic diaphragm valve

The following materials have been used for manufacturing the SVP aseptic diaphragm valve:

- ⇒ Metal parts AISI 316L, AISI 304(L)
- ⇒ All seals Elastomers, PEEK and PTFE
- ⇒ All guides Plastic

### 11.3. Disposal of the SVP aseptic diaphragm valve

Carry out the following work to prepare shutdown of the SVP aseptic diaphragm valve:

- ⇒ Get information on the disposal of the individual components or the entire SVP aseptic diaphragm valve.
  - Ask your environmental officer if necessary.
- ⇒ Disassemble the SVP aseptic diaphragm valve from the closed piping system.
- ⇒ Disassemble the SVP aseptic diaphragm valve as described under "Disassembly - Assembly" (page 16 - 33).
- ⇒ Remove all seals from the valve components of the SVP aseptic diaphragm valve.
- ⇒ Dispose of all components of the SVP aseptic diaphragm valve in a way that excludes any risk to health and damage to the environment.

## 12. Spare parts list

### 12.1. SVP aseptic diaphragm valve - Diaphragm - O-ring

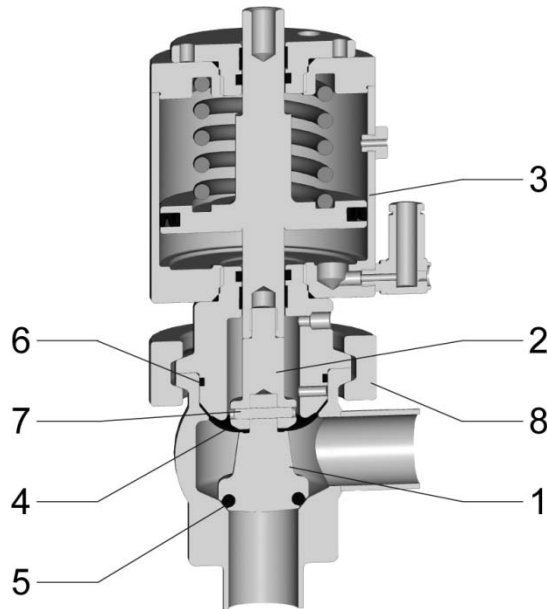

Pos.	Pcs.	Designation	Material		Article no.
1	1	Valve disk	1.4404	DN 10 - 20	2158438
2	1	Stem	1.4301		2158439
3	1	Pneum. control unit			
		air to open - spring to close			2158440
		spring to open - air to close			2144106
		air to open - air to close			2144107
4	1	Diaphragm	P <sup>3</sup>		2144053
5	1	O-ring *	EPDM		2104210
			VMQ		2121979
			FPM		2113209
			HNBR		2130776
6	1	O-ring *	EPDM		2109413
7	1	Cylinder pin	A 2		0073601
8	1	Clamp	1.4301		0034421
	1	Sealing kit consisting of: *	EPDM	2144109	
			VMQ	2144110	
			FPM	2144111	
			HNBR	2144112	

**12.2. SVP aseptic diaphragm valve - Diaphragm - PEEK**

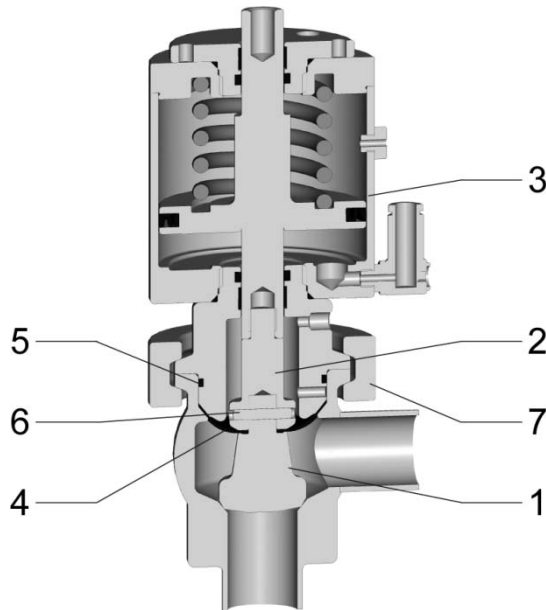

Pos.	Pcs.	Designation	Material		Article no.
1	1	Valve disk	PEEK	DN 10 - 20	2143254
2	1	Stem	1.4301		2158439
3	1	Pneum. control unit			
		air to open - spring to close			2158440
		spring to open - air to close			2144106
		air to open - air to close			2144107
4	1	Diaphragm	P <sup>3</sup>		2144053
5	1	O-ring *	EPDM		2109413
6	1	Cylinder pin	A 2		0073601
7	1	Clamp	1.4301		0034421
	1	Sealing kit consisting of: *	EPDM	2144108	

**12.3. Pneum. control unit**

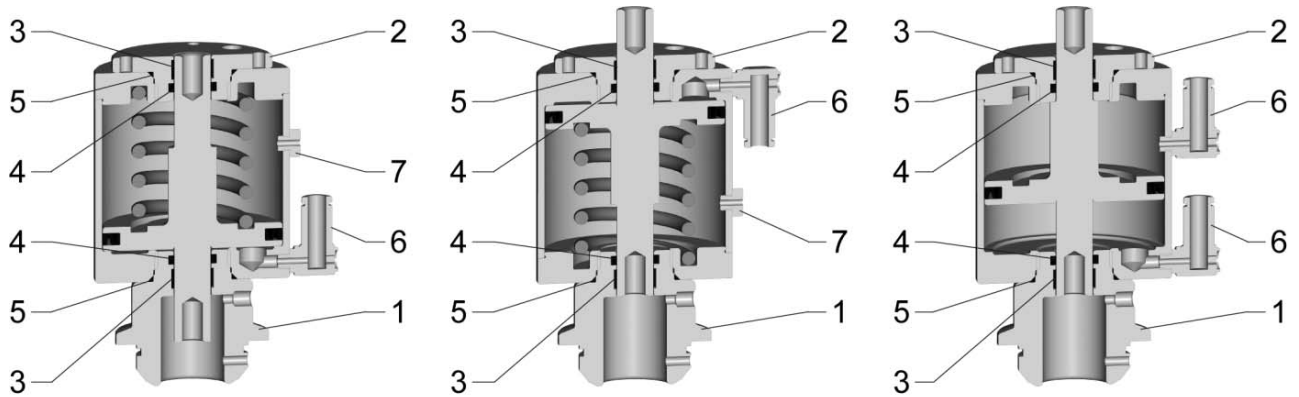

**12.3.1. Mode of operation air to open– spring to close, spring to open– air to close**

Pos.	Pcs.	Designation	Material		Article no.
	1	Pneum. control unit		DN 10 -20	
		air to open - spring to close			2158440
		spring to open - air to close			2144106
1	1	Support	1.4301		2158441
2	1	Locking screw	1.4305		2158437
3	2	Friction bearing *	PEEK		2143887
4	2	O-ring *	NBR		0116962
5	2	O-ring *	NBR		0116699
6	1	Angular screw-in connection			2116512
7	1	Threaded plug			2100250
	1	Sealing kit consisting of: *		2144105	

**12.3.2. Mode of operation air to open - air to close**

Pos.	Pcs.	Designation	Material		Article no.
	1	Pneum. control unit		DN 10 -20	2144107
1	1	Support	1.4301		2158441
2	1	Locking screw	1.4305		2158437
3	2	Friction bearing *	PEEK		2143887
4	2	O-ring *	NBR		0116962
5	2	O-ring *	NBR		0116699
6	2	Angular screw-in connection			2116512
	1	Sealing kit consisting of: *			2144105

### 13. EC Manufacturer's Declaration

according to EC Machinery Directive 98/37/EC, Appendix II B

We hereby declare on our own sole responsibility that the

**SVP aseptic diaphragm valves**

**Type:** A370P<sup>3</sup> Select

**Article No.:** A370P<sup>3</sup> Select – A373P<sup>3</sup> Select

and the valve manifolds manufactured from them, this declaration refers to, conform to the standard(s) or normative document(s) listed below.

**Applied harmonized European standards**

- ⇒ EN 292-1
- ⇒ EN 292-2; EN 60 204-1

**Applied national standards and technical specifications**

UVV 1.2 (VBG 121) Lärm (German Accident Prevention Regulations 1.2 (Regulations for the Employers' Liability Insurance Association 121) entitled "Noise")

UVV 10.0 (VBG 5) Kraftbetriebene Arbeitsmittel (German Accident Prevention Regulations 10.5 (Regulations for the Employers' Liability Insurance Association 5) entitled "Power Operated Equipment")

**Declaration**

The start-up of the valve/valve manifold is prohibited until it has been determined that the machine into which this valve/valve manifold is to be built conforms to the regulations of all relevant and applicable EC directives.

Riesbürg, 16.02.2009



Managing Director  
Oliver Rupp

### 14. CE marking

- ⇒ The nominal diameters DN 25 and smaller are defined according to the definition of the pressure equipment directive 97/23/EC“ according to Article 3 Paragraph 3 good engineering practice and **must not be marked** with the CE mark.

**15. Service address**

Südmo Components GmbH

*Industriestraße 7  
D-73469 Riesbürg - Germany*

*T +49 9081 803-0*

*F +49 9081 803-158*

*E info@suedmo.de*

*I www.suedmo.de*

© 2009 Südmo Components GmbH

Subject to technical modifications

Copy of the Original operating instructions