

SVP Select Valve Program



Product Features

Drawing on many years of experience in the design and construction of valves for the food, dairy, beverage, pharmaceutical, chemical, and cosmetic industries, Norit Südmo developed a comprehensive and modular standard valve program. Manufactured from solid bar stock, Norit Südmo valves are characterized by their machined surfaces, long service life and resistance to aggressive media. They are used in areas where hygienic conditions are of the utmost importance. The actuators come standard with the highest holding pressures on the market and have a 10-year prorated warranty. Additionally, the actuator can be reversed in the field without the use of a press.

All materials are FDA approved and are 3-A compliant. Because all components are machined, higher grade alloys can also be used for the wetted components. The stems are offered with o-rings for superior sealing or PEEK for aggressive media conditions with our standard actuator. The modular design allows for common seal dimensions and common actuators for the various sizes. Because no special tools are required, maintenance of the valve is quick and easy. When needed, the components can be supplied with improved finish and even electropolished. With the addition of Norit Südmo's IntelliTop™, the valves can be operated and monitored through the control system.

Backed by Norit Südmo's proven technology, superior service and extensive application know-how, the Norit Südmo SVP Select Valve series delivers the versatility and reliability that you demand.



SVP Select Valve Program

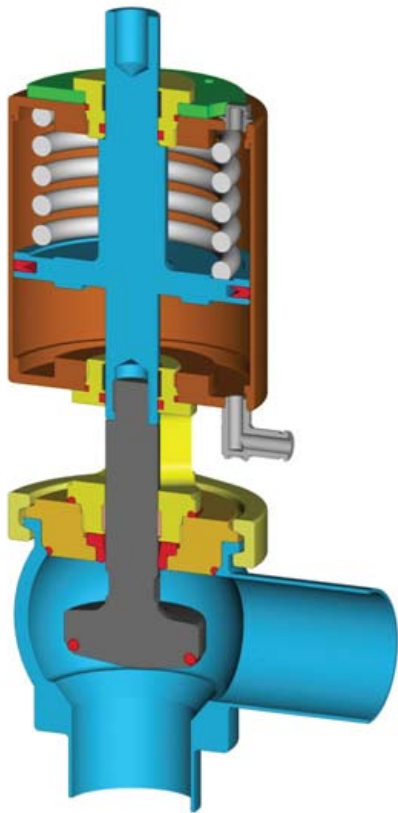

Benefits

- Highest holding pressures
- Body machined from a solid piece of bar stock
- Field reversible actuator
- Modular components
- O-rings (not V-rings) require no special tools for seal insertion
- 10-year prorated actuator warranty

Standard Specifications

Materials

- Product contact: 316L (1.4404)
- Non product contact: 304 (1.4301)
- Optional: Hastelloy, AL6XN

Seals

- Standard: EPDM
- Optional: HNBR, PEEK, FPM (Fluoro-Rubber), FFKM (Perfluorinated Fluoro-Rubber)

Operating Pressures

- Control air pressure: Standard 87-116 psi
- Optional: 50 psi with booster
- Product pressure: Standard 87 psi with 87 psi air pressure
- Holding pressure: Min. 100 psi with o-ring stem

Connections

- Standard: Sanitary O.D. tube butt weld
- Optional: Sanitary O.D. tube clamp
Welding ends for metric tubes
Welding ends for ISO tubes
DIN nut

Finishes

- <= 32 Ra product contact
- <= 63 Ra non-product contact

Options

- Improved mechanical polish/electropolish
- Control top
- Mid-position actuator
- Adjustable mechanical stop
- Long stroke
- Booster
- **P³** aseptic diaphragm
- 3.1B material certification



Súdmo North America, Inc.

1330 Anvil Drive, Rockford, IL 61115 USA

T 815.639.0322 • F 815.639.1135

E info@sudmona.com • I www.sudmona.com

Súdmo North America, Inc. reserves the right to make changes in the technical specifications at any time.