

BAA A912

Version 1.00

Aseptic sampling valve

PTFE bellows
manually and pneumatically actuated

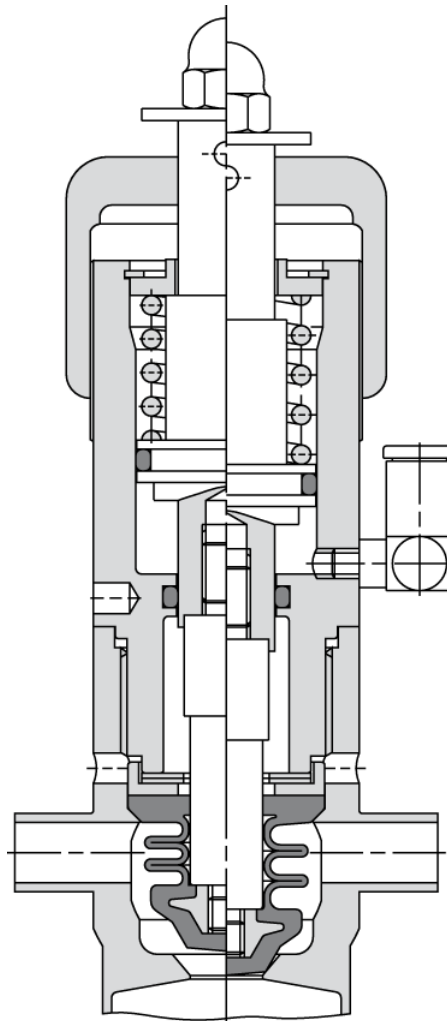

| | | | | | | | | | | | | |
|----------|------|------|----------|------|------|----------|------|------|----------|------|------|--|
| | | | | | | | | | | | | |
| Revision | Date | Name | Revision | Date | Name | Revision | Date | Name | Revision | Date | Name | |

created on/by 04.03.2010 Graf
 reviewed on/by 04.03.2010 Neumeyer W. 1



en

1. Contents

| | |
|--|----------|
| 1. Contents | 2 |
| 2. Safety instructions..... | 4 |
| 2.1. General information..... | 4 |
| 2.2. Maintenance and service work..... | 4 |
| 2.3. Modifications to the aseptic sampling valve | 5 |
| 2.4. Storage..... | 5 |
| 2.5. Operation | 5 |
| 2.6. Spare parts..... | 5 |
| 2.7. Risk assessment | 5 |
| 3. Technical Data | 6 |
| 3.1. Valve use | 6 |
| 3.2. Material data..... | 6 |
| 3.2.1. Sealing materials | 6 |
| 3.2.2. Stainless steels | 6 |
| 3.3. CIP cleaning..... | 7 |
| 3.4. Surfaces | 7 |
| 3.5. Pneumatic connections | 7 |
| 3.5.1. Pneumatic connections | 7 |
| 3.5.2. Air hose..... | 7 |
| 3.6. Control air..... | 8 |
| 3.6.1. Control air pressure..... | 8 |
| 3.6.2. Control air quality | 8 |
| 4. Valve function | 8 |
| 4.1.1. Manual actuator | 8 |
| 4.1.2. Pneumatic actuator | 8 |
| 5. Valve connection piping..... | 9 |
| 5.1. Installation position | 9 |
| 5.2. Valve connections | 9 |
| 5.3. Installation instructions | 9 |
| 6. Installation instructions | 9 |
| 6.1. General notes..... | 9 |
| 6.2. As-delivered condition | 9 |
| 6.3. Installation instructions | 9 |
| 6.3.1. Installation space | 9 |
| 6.3.2. Installation..... | 9 |
| 6.4. Welding instructions | 10 |
| 6.4.1. Field of application | 10 |
| 6.4.2. Welding process | 10 |
| 6.4.3. Type of seam | 10 |
| 6.5. Weld seam preparation | 10 |
| 6.6. Welding | 10 |
| 6.7. Weld filler..... | 10 |
| 6.8. Weld seam finishing | 10 |
| 6.8.1. Interior..... | 10 |
| 6.8.2. Exterior..... | 10 |
| 6.9. Cleaning | 10 |

| | |
|--|-----------|
| 6.10. Assembly..... | 10 |
| 7. Disassembly - Assembly | 11 |
| 7.1. Prior to disassembly | 11 |
| 7.2. Spare parts..... | 11 |
| 7.3. Replacement of the seals..... | 12 |
| 8. Start-up | 14 |
| 8.1. Functional test..... | 14 |
| 8.2. Leak test..... | 14 |
| 9. Maintenance | 14 |
| 9.1. Before maintenance | 14 |
| 9.2. Inspection | 15 |
| 9.3. Maintenance..... | 15 |
| 10. Malfunctions - Troubleshooting | 15 |
| 11. Disposal..... | 16 |
| 11.1. Before disposal..... | 16 |
| 11.2. Components of the aseptic sampling valve | 16 |
| 11.3. Disposal of the aseptic sampling valve..... | 16 |
| 12. Spare parts list..... | 17 |
| 13. EC Declaration of Incorporation | 18 |
| 14. Service address | 20 |

2. Safety instructions



This symbol denotes an imminent danger to life and health of persons! Non-observance of these instructions leads to health risks or life-threatening injuries.



This symbol denotes a potentially imminent danger! Non-observance of these instructions can lead to light injuries or damage to material property.



This symbol gives important information on proper handling of the aseptic sampling valve which must be observed strictly. Non-observance of these instructions can result in malfunction of the valve or in its environment.

2.1. General information

- ⇒ The aseptic sampling valves from Südmo Components GmbH have been manufactured in accordance with state-of-the-art standards and recognized safety rules. However, these aseptic sampling valves may constitute a hazard if used by operating personal improperly or for a purpose other than the designated use. This may result in a risk to life and limb of the user or of third parties, or cause damage to the aseptic sampling valve and other material property.
- ⇒ Anyone who has been designated by the purchaser to install, start up, operate and maintain this aseptic sampling valve must have read and understood the complete operating instructions (especially all stipulated safety instructions).
- ⇒ In addition to these operating instructions the following applies as a matter of course:
 - relevant accident prevention regulations
 - generally recognized safety rules
 - national regulations in the country of use
 - company-internal instructions concerning work and safety.

2.2. Maintenance and service work

- ⇒ Any maintenance and service work on the aseptic sampling valves must be carried out by qualified personnel only. Qualified personnel as defined by these operating instructions are persons who are familiar with installation, start-up and operation of this product and who have the necessary qualification for their work, including
 - Training or instruction on service and use of the appropriate safety equipment in accordance with the current safety standards
 - First aid training
 - For systems with explosion protection: training or instruction or authorization to carry out work on systems subject to explosion hazards (observe ATEX regulations).
- ⇒ Prior to carrying out any maintenance and service work, the following must be ensured and observed:
 - Draining of the pipeline
 - Carry out this work only in depressurized condition and with the media supply shut off
 - Get information on possible risks which could be caused by residues of the operating material and take appropriate measures, if necessary (safety gloves, safety goggles, etc.)
 - Allow the fittings to cool down, if necessary.
 - Prevent the system from being started up by a third person.
 - Counteract pressure build-up in sealed pipelines.
 - Carry out installation according to the assembly instructions.
 - Remove the aseptic sampling valve from the piping section, if possible.

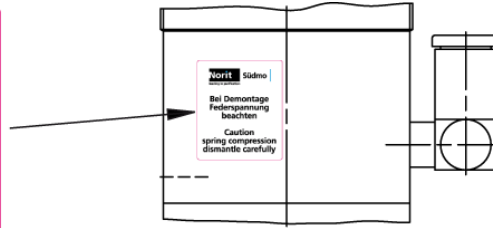
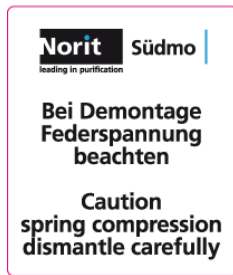

Diagram A

⇒ Avoid any working method that impairs safety and function of the aseptic sampling valve.

2.3. Modifications to the aseptic sampling valve

⇒ The user is obliged to operate the SVP aseptic control valve according to the designated use and safety instructions, being aware of the risks and dangers involved in operating the valve. Changes emerging on the aseptic sampling valve which impair function and safety must be reported immediately. The user is obliged to operate the aseptic sampling valve in perfect condition only.



Modifications to the aseptic sampling valve are strictly forbidden

2.4. Storage

⇒ Store the valve at a dry location and protected from external influences.
⇒ Prior to handling (disassembly of the body / activation of the actuators) store the valves temporarily in a dry condition for at least 24 hours at a temperature $\geq 5^\circ \text{C}$.

2.5. Operation



- ⇒ **Never touch the valve or the pipelines if hot media are processed or if the sterilizing process is running.**
- ⇒ **Always adhere to the operating parameters (see Technical Data – page 6).**
- ⇒ **We cannot be held liable for improper operation of the valve.**

2.6. Spare parts



- ⇒ **Use original Norit Südmö spare parts only**
- ⇒ **For Norit Südmö spare parts, refer to the enclosed spare parts list**
- ⇒ **If other spare parts are used**
- **Exclusion of liability**

2.7. Risk assessment

⇒ All safety instructions in these operating instructions result from the risk assessment for the aseptic sampling valve.

3. Technical Data

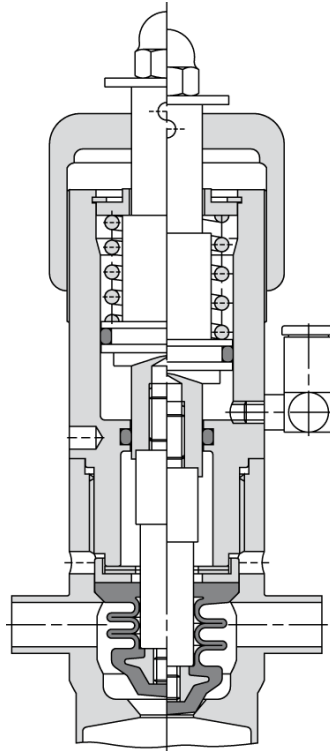

3.1. Valve use

| | |
|--------------------|-------------------|
| Application | Sampling valve |
| Use | Aseptic processes |
| Shut-off tightness | max. 10 bar |

3.2. Material data

3.2.1. Sealing materials

⇒ Seals in contact with product

| | |
|---|-----------------------|
| PTFE bellows | TFM 1600 |
| Temperature for continuous application: | max. 120° C |
| SIP: | max. 135° C / 20 min. |



The service lives of the seals depend on:

- ⇒ **Operating time per day**
- ⇒ **Switching intervals**
- ⇒ **Type of product, temperature etc.**
- ⇒ **Type of cleaning (CIP / SIP)**

3.2.2. Stainless steels

| | |
|------------------------------|--------|
| In contact with product: | 1.4404 |
| Not in contact with product: | 1.4301 |
| Spring washer | 1.4310 |
| Compression spring | 1.4310 |

3.3. CIP cleaning



- ⇒ Valve inner chambers must be cleaned regularly
- ⇒ When selecting the detergent, please observe the following:
 - Do not use abrasive detergents.
 - Use only detergents that do not attack seals and stainless steel.
- ⇒ Do not exceed the concentrations and temperatures recommended by the detergent manufacturer.
- ⇒ Adequate and competent handling and disposal of detergents.
- ⇒ Observe the safety data sheets issued by the detergent manufacturers!
- ⇒ Non-observance of these instructions will exempt the manufacturer from any warranty and liability.

3.4. Surfaces

Surfaces in contact with the product: $R_a \leq 0.8 \mu\text{m}$
Optionally: electropolished
Surfaces not in contact with product: bright metal finish

3.5. Pneumatic connections

3.5.1. Pneumatic connections

- ⇒ Angular screw-in connection M 5, air hose PE dia. 6/ 4
- ⇒ USA:
Angular screw-in connection M 5, air hose PE 1/4" (dia. 6.35)

3.5.2. Air hose

Always use hose quality according to Norit Südmo article no. 0490227 (6/4 hose) or equivalent:

- ⇒ Black air hose
- ⇒ Material: Polyamide 12
Linear coefficient of expansion: 15×10^{-5}
Version according to DIN 73378 soft
- ⇒ Max. operating pressure: OD 6/ ID 4 = 27 bar
all pressure indications at 20°C, higher temperatures have a negative effect on the max. operating pressure



- ⇒ Use only calibrated hose pipes with an external diameter of 6 mm or 1/4" (tolerance +0.05/-0.1).
- ⇒ Cut the hose pipe only with a special hose cutter, otherwise the pipe can be damaged.
- ⇒ Improper cutting can result in a leak at the cutting point which can cause pressure loss.
- ⇒ The length of the hose must be dimensioned in a way that the hose cannot buckle. Even single buckling of the hose damages it permanently. This can cause pressure loss or interruption of the air supply. Please refer to manufacturer's instructions regarding the minimum bending radius of the hose.
- ⇒ Insert the air hose tangentially into the connector and fasten it. Avoid diagonal deflection of the hose at the connector as the air hose may buckle or leakages can occur. This can cause pressure loss or interruption of the control air supply.

3.6. Control air

3.6.1. Control air pressure

min. 6 bar – max. 10 bar



Use only clean and dry control air!

3.6.2. Control air quality

to DIN ISO 8573.1

| | | |
|-----------------------|--|--|
| <u>Solids content</u> | Particle size | max. 5 µm |
| | Particle density | max. 5 mg/m ³ (quality grade 3) |
| <u>Water content</u> | Quality grade 3 | |
| | Dew point | -20° C |
| | or min. 10° C below the lowest ambient temperature | |
| <u>Oil content</u> | Quality grade 3, preferably oil free, max. 25 mg of oil in 1 m ³ of air | |

4. Valve function

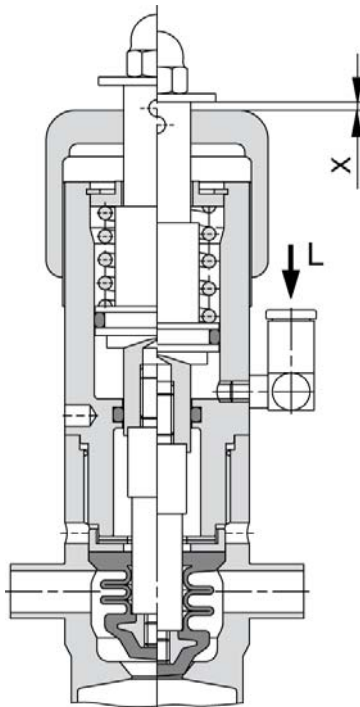

4.1.1. Manual actuator

Valve position "Closed"

- ⇒ Initial position
- ⇒ Control air pressure 0 bar to air connection L
- ⇒ Rotate handwheel clockwise.
- ⇒ Measure X with valve closed min. 1 mm
- ⇒ Closing force against product pressure 10 bar.

Valve position "Open"

- ⇒ Control air pressure 0 bar to air connection L
- ⇒ Rotate handwheel counter clockwise.

4.1.2. Pneumatic actuator

Valve position "Closed"

- ⇒ Valve is in initial position
- ⇒ Control air pressure 0 bar to air connection L
- ⇒ Safety position
- ⇒ Closing force against product pressure 10 bar.

Valve opens

- ⇒ Control air pressure 6 bar to air connection L

5. Valve connection piping

5.1. Installation position

Vertical, horizontal
Ensure that product can drain from the valve and piping.

5.2. Valve connections

Welding end
For welding instructions refer to page 9.

5.3. Installation instructions

For valve disassembly refer to page 11.



- ⇒ *Dismount the seals before carrying out any welding work.*
- ⇒ *Valve body must be free from tension and distortions when welded.*
- ⇒ *Welding work must be carried out only by qualified personnel (DIN 287-1 W11).*
- ⇒ *Do not allow any foreign objects to enter the piping.*

6. Installation instructions

6.1. General notes

It is strongly recommended to have installation work done by specially trained, qualified personnel.



Welding work must be carried out only by qualified personnel (DIN 287-1 W11).

We cannot be held liable for any damage resulting from incorrect installation.

6.2. As-delivered condition

- ⇒ Factory-tested and configured.
- ⇒ Ready for installation or prepared for welding into the piping

6.3. Installation instructions

6.3.1. Installation space

Before starting the assembly work determine and define the connection axes. Observe the installation dimensions specified in the dimensional drawings.

Ensure that there is sufficient space available for both operation and maintenance.

6.3.2. Installation

Make sure that the fittings and piping are not subject to any tensile or compressive stresses.

6.4. Welding instructions

6.4.1. Field of application

Welding of fittings into pipes according to DIN 11850 series 1, 2; OD-Tube; DIN EN ISO 1127

6.4.2. Welding process

TIG (tungsten inert gas welding)

6.4.3. Type of seam

- ⇒ Preparation of the seam according to DIN 2559 (edge form I / for I-seams)
- ⇒ Weld seams correspond to DIN EN ISO 5817 → Quality group B (high)

6.5. Weld seam preparation

Saw off the pipe ends planar at the right angle and debur them (pipe saw M882). Align the welding ends of the valve body and piping radially and axially, ensuring they are fitted flush together (centering device).



There must be no gap at the flush-fitted welding ends as the quality and corrosion resistance of the weld seam would be impaired by the escaping forming gas.

6.6. Welding

Connect the forming gas. Tack at 3 or 4 points. Type of welding: TIG-manual or orbital (automatic welding).

6.7. Weld filler

Material allocation

| Material of parts to be welded | Suitable weld filler | | |
|--------------------------------|----------------------|--------|--------|
| | 1.4430 | 1.4440 | 1.4519 |
| 1.4404 | X | | |
| 1.4435 | X | X | X |
| 1.4571 | X | X | |

6.8. Weld seam finishing

6.8.1. Interior

Weld seam finishing not required. Improvement of surface finish by scotching (at accessible points).

6.8.2. Exterior

Weld finishing methods

- ⇒ Pickling - Ensure proper disposal of pickling paste
- ⇒ Brushing
- ⇒ Grinding
- ⇒ Polishing

6.9. Cleaning

Clean thoroughly before assembly.

6.10. Assembly

Carry out installation according to the assembly instructions.

7. Disassembly - Assembly

7.1. Prior to disassembly

Carry out installation according to the assembly instructions.

Before disconnecting the valve connections, carry out the following steps:



Danger

- ⇒ **Make sure that no process is running in the respective area during maintenance and service work.**
- ⇒ **Drain off all piping elements leading to the aseptic sampling valve, clean and rinse them, if necessary.**
- ⇒ **Shut off the control air if it is not needed for disassembly.**
- ⇒ **Remove the aseptic sampling valve from the piping section if possible.**

Prior to assembly clean and grease the shafts and sliding surfaces. Grease the sealing elements before installation.

| Sealing materials | Grease type |
|-------------------|------------------|
| TFM1600 | No grease |
| NBR | RENOLIT SI 410 M |



Caution

- ⇒ **If a different grease is used**
→ **corrosion of the sealing elements.**
- ⇒ **Do not use mineral greases and animal fat.**
- ⇒ **Do not use petroleum grease.**

7.2. Spare parts



Caution

- Use original Norit Südmo spare parts only**
- ⇒ **For Norit Südmo spare parts, refer to the enclosed spare parts list**
- ⇒ **If other spare parts are used**
→ **Exclusion of liability**

7.3. Replacement of the seals



Avoid any damage to the metallic surfaces of the valve disks and to the valve disk seals.

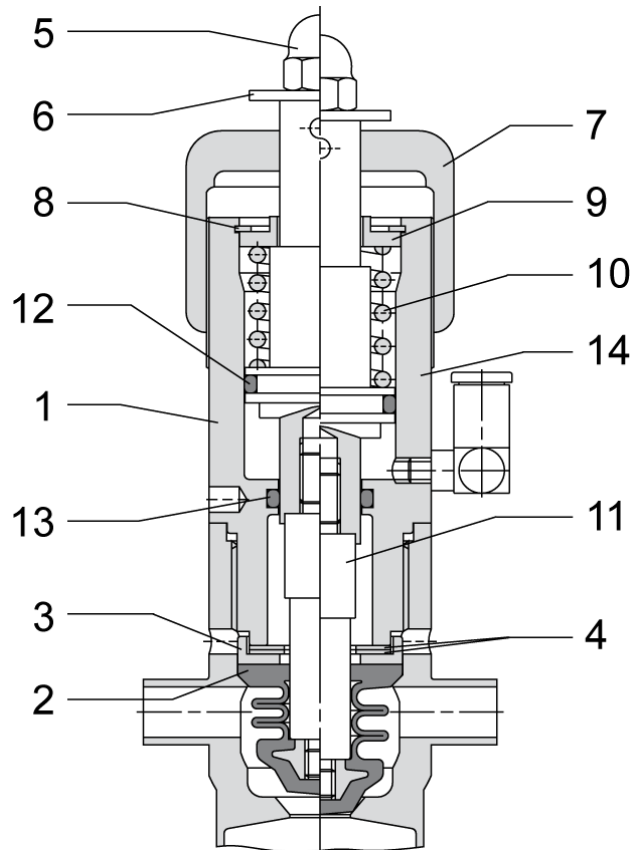

Disassembling the valve

- I.1. Disconnect pneum. supply line.
- I.2. Open valve by rotating the handwheel (7) counter clockwise.
- I.3. Remove upper part of the valve (1) from the valve body.
- I.4. Rotate the handwheel (7) downwards in clockwise direction until the stop.
- I.5. Remove the PTFE bellows (2).
- I.6. Remove pressure washer (3) and spring washers (4).
- I.7. Dismount cap nut (5) and remove disk (6).
- I.8. Unscrew handwheel (7).
- I.9. Dismount circlip (8) and remove stop (9).



⇒ Pay due regard to the spring tension forces during dismantling.

- I.10. Remove compression spring (10).
- I.11. Remove piston rod (11) from actuator seat (14) and dismount O-ring (12).
- I.12. Remove O-ring (13).

Replacing the seal

I.13. Replace the seals.



Use original Norit Südmo spare parts only

⇒ **For Norit Südmo spare parts, refer to the enclosed spare parts list**

⇒ **If other spare parts are used**
→ **Exclusion of liability**

I.14. Grease the sealing elements before installation.

| Sealing materials | Grease type |
|-------------------|------------------|
| TFM1600 | No grease |
| NBR | RENOLIT SI 410 M |



⇒ **If a different grease is used**

→ **corrosion of the sealing elements.**

⇒ **Do not use mineral greases and animal fat.**

⇒ **Do not use petroleum grease.**

Assembling the valve

I.15. Prior to assembly clean and grease the shafts and sliding surfaces.

I.16. Install O-ring (13).

I.17. Install O-ring (12) in piston rod (11).

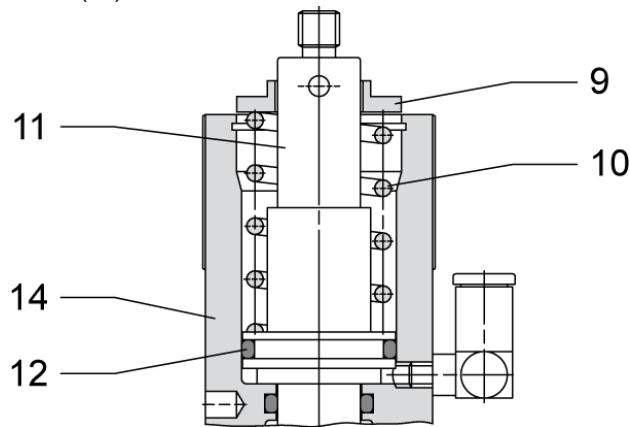

I.18. Mount piston rod (11) in actuator seat (14).

I.19. Insert compression spring (10) in piston rod (11).

I.20. Mount stop (9).



Ensure correct installation position of stop (9)!

I.21. Install circlip (8).



⇒ **During assembly ensure correct spring tension.**

I.22. Screw handwheel (7) onto actuator seat (14) until the stop.

- I.23. Mount disk (6) and cap nut (5).
I.24. Place spring washers (4) on actuator seat (14).

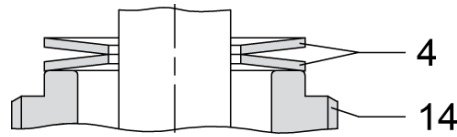

Ensure correct installation position of spring washers (4)!

- I.25. Slide pressure washer (3) onto stem (11).
I.26. Screw PTFE bellows (2) onto piston rod (11).
I.27. Bring valve into open position by rotating the handwheel (7) clockwise.
I.28. Screw upper part of the valve (1) into valve body.
I.29. Bring valve into closed position by rotating the handwheel (7) counter clockwise.
I.30. Connect pneumatic supply line.

8. Start-up



- ⇒ **Ensure that no foreign objects are present in the piping system.**
- ⇒ **Avoid temperature shock!**
Warm up the fitting slowly to the operating temperature.

8.1. Functional test

Switch valve once.
The system must be cleaned before the first product run.

8.2. Leak test

Check visually if the seals have any leaks.
Replace defective seals.

9. Maintenance

9.1. Before maintenance



- ⇒ **Make sure that no process is running in the respective area during maintenance and service work.**
- ⇒ **Drain off all piping elements leading to the aseptic sampling valve, clean and rinse them, if necessary.**
- ⇒ **Shut off the control air if it is not needed for disassembly.**
- ⇒ **Remove the aseptic sampling valve from the piping section if possible.**
- ⇒ **Maintenance work must be carried out by qualified and trained personnel only.**

9.2. Inspection

Norit Südmo valves do not require special maintenance. In the intervals between maintenance procedures, however, it is necessary to check the tightness and correct operation of the seals by means of regular visual inspections.

9.3. Maintenance

Practice-oriented maintenance intervals can only be determined by the respective user/operator as they depend on the following application parameters:

- ⇒ Operating time per day
- ⇒ Switching intervals
- ⇒ Type of product
- ⇒ Type of cleaning (CIP / SIP)

We can recommend the following data as reference values:

- ⇒ for liquids with solid particles and temperatures of 80° C to 100° C approx. every 3-6 months
- ⇒ for liquids with solid particles and temperatures of 60° C every 12 months
- ⇒ for liquids without solid particles and temperatures of max. 60° C every 24 months.

Intervals of 12 months are recommended for cleaning systems.

Of course, the intervals stated above require sufficient chemical resistance of the sealing materials.

10. Malfunctions - Troubleshooting



- ⇒ **Never touch the valve or the pipelines if hot media are processed or if the sterilizing process is running.**
- ⇒ **Always adhere to the technical data.**
- ⇒ **We cannot be held liable for improper operation of the valve.**



- ⇒ **In case of malfunctions, shut off the valve immediately and secure it against restart.**
- ⇒ **Malfunctions must be eliminated by qualified and trained personnel only while observing the safety instructions.**

| Malfunctions | Cause | Troubleshooting |
|----------------------|--|--|
| Valve does not work | ⇒ Fault in the control system | ⇒ Check the system configuration |
| | ⇒ No compressed air | ⇒ Check compressed air supply |
| | ⇒ Compressed air level is too low | ⇒ Check if air hoses are free and tight |
| | ⇒ Pilot valve is defective | ⇒ Replace the pilot valve |
| Valve does not open | ⇒ Seal on the stem is defective | ⇒ Replace the seals |
| | ⇒ Seals in the actuator are defective | ⇒ Replace the seals |
| | ⇒ Stop mounted incorrectly in the actuator | ⇒ Dismount actuator and rotate stop |
| Valve does not close | ⇒ Dirt / foreign objects in the seat area | ⇒ Clean the valve body and the area of the seal, valve disk/closing sleeve |

12. Spare parts list

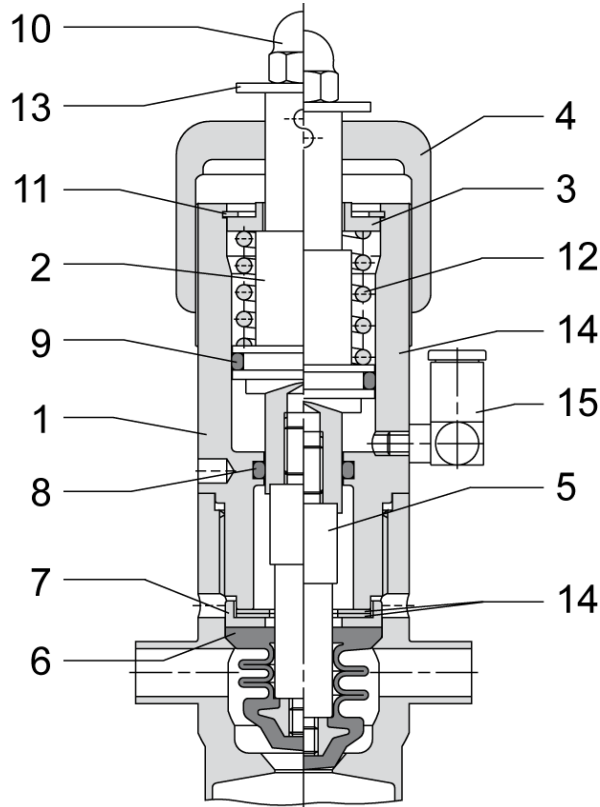

| Pos. | Part | Designation | Material | Article no. |
|------|------|-----------------------------|----------|-------------|
| | 1 | Valve upper part | | 2122890 |
| 1 | 1 | Actuator seat | 1.4301 | 2122888 |
| 2 | 1 | Piston rod | 1.4301 | 2152506 |
| 3 | 1 | Stop | 1.4301 | 2152507 |
| 4 | 1 | Handwheel | POM | 2117234 |
| 5 | 1 | Stem | 1.4301 | 2122887 |
| 6 | 1 | PTFE bellows | TFM 1600 | 0998740 |
| 7 | 1 | Pressure washer | 1.4301 | 2120191 |
| 8 | 1 | O-ring | NBR | 0116871 |
| 9 | 1 | O-ring | NBR | 0116681 |
| 10 | 1 | Cap nut | A 2-70 | 0165282 |
| 11 | 1 | Circlip | 1.4310 | 0478073 |
| 12 | 1 | Compression spring | 1.4310 | 0981811 |
| 13 | 1 | Disk | 1.4404 | 0858944 |
| 14 | 2 | Spring washer | 1.4310 | 0998773 |
| 15 | 1 | Angular screw-in connection | | 2116512 |

13. EC Declaration of Incorporation

The manufacturer,

Südmo Components GmbH
Industriestraße 7
D-73469 Riesbürg-Pflaumloch

hereby declares that the:

Aseptic Sampling Valves

Type: A912
Article No.: A912
Year of manufacture: 2010

comply with the following basic requirements of the **Machinery Directive (2006/42/EC)**.

Appendix I, Articles 1.1.2, 1.1.3, 1.1.5, 1.3.2, 1.3.4, 1.5.3, 1.5.4, 1.5.5, 1.5.13, 1.6, 1.7.1, 1.7.2, 1.7.3, 1.7.4 and 2.1.

The partly completed machine / system component furthermore complies with all regulations of the directives **Electrical equipment (2006/95/EC)** and **Electromagnetic compatibility (2004/108/EC)**.

Applied harmonized standards

- ⇒ DIN EN 12100-1 Safety of machinery – Basic terms, general principles for design - Part 1: Basic terminology, methods
- ⇒ DIN EN 12100-2 Safety of machinery – Basic terms, general principles for design, part 2: Technical principles and specifications
- ⇒ DIN EN 60204-1 Safety of machinery - Electrical equipment of machines, Part 1: General requirements
- ⇒ DIN EN 1672-2 Food processing machinery – Basic concepts – Part 2: Hygiene requirements

Do not put the partly complete machine / system component into operation unless it has been verified that the machine/system the partly complete machine/system component is to be built into complies with the regulations of the machinery directive (2006/42/EC).

TD authorized person

Engineering management: Werner Deger,
Südmo Components GmbH
Industriestraße 7, D-73469 Riesbürg

Riesbürg, 04.03.2010

Managing Director
Oliver Rupp

Operating Instructions

Aseptic sampling valve
PTFE bellows
manually and pneumatically actuated

BAA A912

Version 1.00

created on/by 04.03.2010

reviewed on/by 04.03.2010

Graf Holger
Neumeyer W.



en

14. Service address

Südmö Components GmbH

*Industriestraße 7
D-73469 Riesbürg - Germany*

T +49 9081 803-0

F +49 9081 803-158

E info@suedmo.de

I www.suedmo.de

© 2010 Südmö Components GmbH

Subject to technical modifications